

Hard-Mounted Hollow Retroreflector (HMHR™)

Description

The HMHR™ is constructed of three first-surface mirrors assembled by a proprietary process into a mutually-orthogonal inside corner.

Features / Characteristics

The mirrors can be coated for maximization over a spectral range, from UV to far IR. This hollow configuration eliminates material absorption and chromatic aberration. The mirror assembly of the HMHR™ is mounted on an Invar mount. (5.0"/127 mm unit comes with aluminum mount). Invar is a low-expansion (CTE 0.75 ppm/K) alloy of iron and nickel that is used when control of thermally-induced dimensional change is required.



Applications

The HMHR™ offers properties which make it especially suitable for critical applications, such as Michelson interferometers. The mount maintains stability of the distance between the apex of the corner cube and the back surface of the mount, as well as concentricity of the apex with respect to the mounting thread. HMHR™s can also be provided in matched pairs for better modulation. Parts are able to withstand military and space environments.

Specifications

Substrate	Pyrex
Housing material	Invar
Surface flatness	$\lambda/10 - \lambda/20 @ 633 \text{ nm}$
Surface quality	80 – 50 Scratch-Dig
Beam deviation	0.5 – 30.0 Arcsecond

Hard-Mounted Hollow Retroreflector (HMHR™)

Item	Beam Deviation (arc. sec)	Exiting Wavefront (p. v. 633 nm)	Weight (grams)
HM-10	1.0 – 30.0	0.15 – 3.50	25
HM-15	0.5 – 30.0	0.10 – 5.25	45
HM-20	0.5 – 30.0	0.15 – 7.00	90 – 110
HM-25	0.5 – 30.0	0.25 – 9.00	110 – 141
HM-50	0.5 – 30.0	0.45 – 18.00	551 – 780

Item	Accuracy (arc. sec)	ØA (in/mm)	B (in/mm)	C (in/mm)	D (in/mm)
HM-10	1.0 – 30.0	1.00/25.40	1.41/35.77	1.13/28.75	0.41/10.42
HM-15	0.5 – 30.0	1.50/38.10	1.93/49.05	1.57/39.79	0.52/13.24
HM-20	0.5 – 1.0	2.00/50.80	2.55/64.81	2.11/53.56	0.71/17.92
HM-20	2.0 – 30.0	2.00/50.80	2.48/62.94	1.92/48.88	0.52/13.24
HM-25	0.5 – 1.0	2.38/60.33	3.00/76.32	2.38/60.45	0.71/17.92
HM-25	2.0 – 30.0	2.38/60.33	2.93/74.45	2.20/55.77	0.52/13.24
HM-50	0.5 – 1.0	4.56/115.89	5.52/140.09	4.54/115.23	0.84/21.38
HM-50	2.0 – 30.0	4.56/115.89	5.47/138.85	4.42/112.30	0.73/18.44

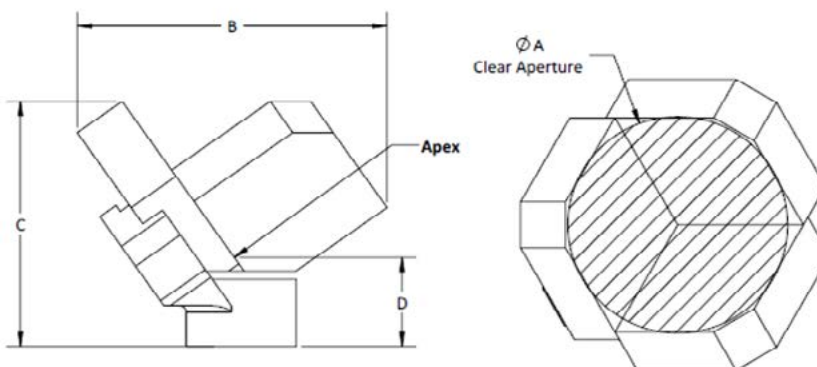

Simulations

Coating types

Enhanced Aluminum (400 – 700 nm),	93% (AOI 55° per surface reflectance average)
IR Enhanced Aluminum (600 – 1.600 nm)	89% (AOI 55° per surface reflectance average)
Unprotected Aluminum (225 – 10.000 nm)	90% (AOI 55° per surface reflectance average)
UV Enhanced Aluminum (225 – 700 nm)	89% (AOI 55° per surface reflectance average)
Protected Silver (450 – 10.000 nm)	96% (AOI 55° per surface reflectance average)
Protected Gold (650 – 16.000 nm)	97% (AOI 55° per surface reflectance average)
Unprotected Gold (650 – 20.000 nm)	97% (AOI 55° per surface reflectance average)
Protected Aluminum (400 – 750 nm)	87% (AOI 55° per surface reflectance average)

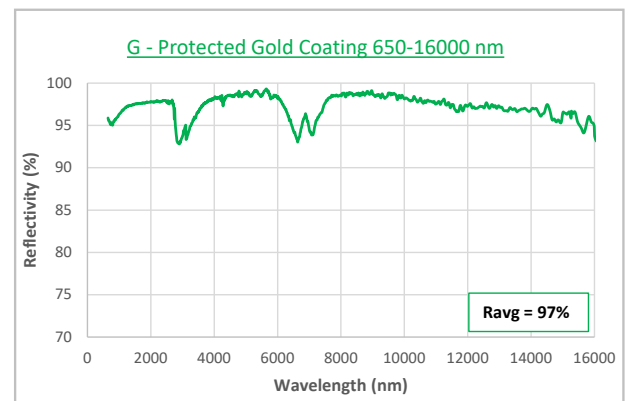
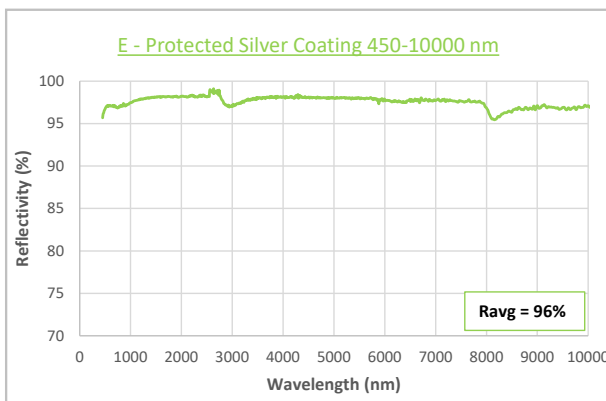
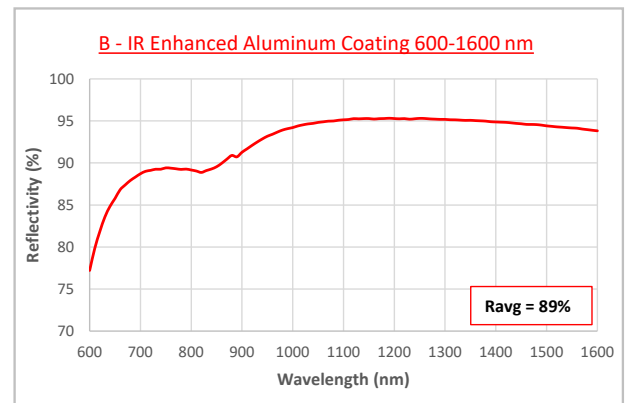
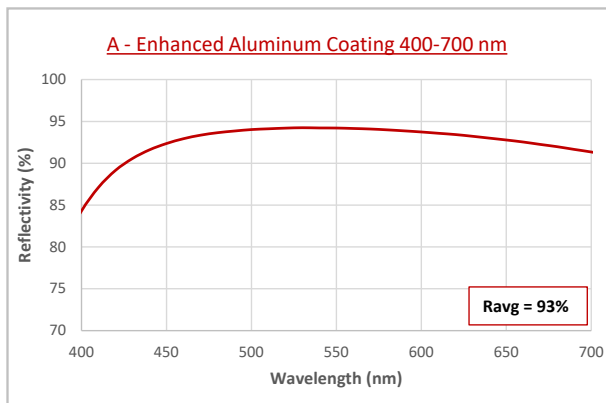

Note:

Coatings meet Ravg requirement, but coating curves are for reference as $R(\lambda)$ may vary $\pm 2\%$. Detailed drawings and detailed coating curves are available on request.

Good to know

- Standard HMHR™ mirror coatings are aluminum, silver and gold, in both bare metal and with protective overcoats. All protected PLX coatings meet MIL-SPEC durability and adhesion requirements. Unprotected metallic coatings are especially suited to interferometric applications. Custom coatings available.
- **Custom configurations for specialized applications**
Engineers can create a custom HMHR™ for your application. Potential variations include: smaller and larger apertures; modified hard mounts to meet your interface; super-critical accuracies; dielectric mirror coatings for high-powered lasers; and units able to withstand military and space environments.
- **Beam Deviation** is the maximum deviation from parallelism, expressed in seconds of arc, of any single return beam from any of the ϕ sub-apertures of the retroreflector, when the retroreflector is fully-illuminated.
- **Exiting Wavefront** is the resultant maximum peak-to-valley wavefront deformation from a fully-illuminated retroreflector, where $\lambda = 633 \text{ nm}$.
- Beam deviation and exiting wavefront are interrelated, and it is only necessary to specify one.
- Certain high accuracy models may be heavier than indicated here. Check with us for actual weight.

For inquiries we need to know:

- Which type of retroreflector
- CA
- Beam deviation
- Coating

Product Code

Type of retroreflector -

CA -(inch)

Beam deviation (arc.sec)

Coating

For example:

HM-10-5PG, Hollow retroreflector, prot.gold, Ø1.0", 5"acc.,M6 thr

(Hard-Mounted hollow retroreflector, CA 1 inch = 25.4 mm, beam deviation= 5 arcsec with protected gold coating, with M6 threaded hole)