

# AlGaInP Visible Laser Diode

## ★650nm 5mW 70°C Reliable Operation

### • Features

1. High temperature operation
2. FFP single lateral mode
3. High reliability
4. Excellent far field pattern.

### • Applications

1. Laser pointers
2. Industrial laser markers / measuring instruments
3. Bar code readers

### • Absolute maximum ratings

Parameter	Symbol	Condition	Rating	Unit
Light output power	$P_O$	CW	7	mW
Reverse voltage (LD)	$V_{RL}$	-	2	V
Reverse voltage (PD)	$V_{RD}$	-	30	V
Forward current (PD)	$I_{FD}$	-	10	mA
Case temperature	$T_C$	-	-10~+70	°C
Storage temperature	$T_S$	-	-40~+85	°C

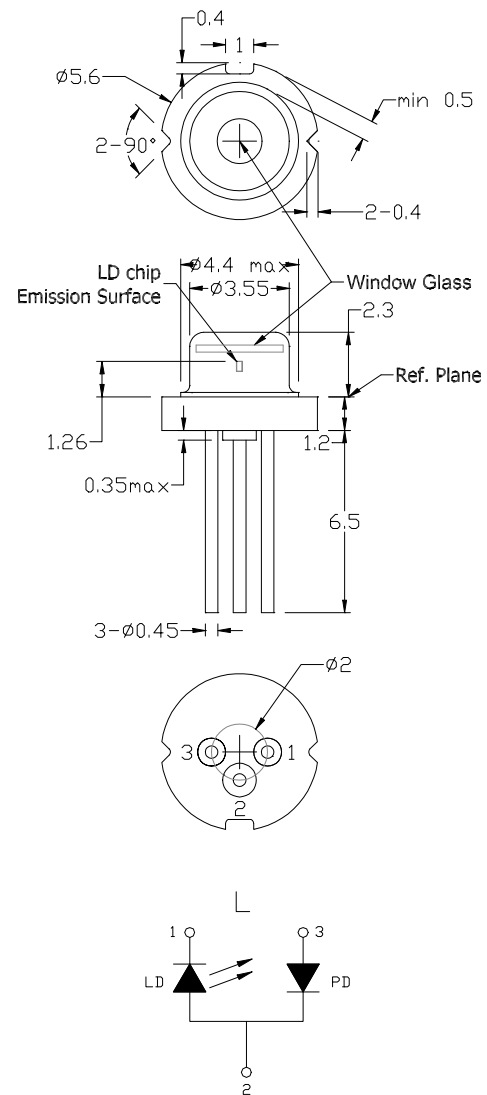

### • Electrical and optical characteristics ( $T_c=25^\circ\text{C}$ )

Parameter	Symbol	Min.	Typ.	Max.	Unit	Conditions
Peak wavelength	$\lambda$	645	655	660	nm	$P_o=5\text{mW}$
Threshold current	$I_{th}$	-	20	25	mA	
Operating current	$I_{op}$	-	25	35	mA	$P_o=5\text{mW}$
Operating voltage	$V_{op}$	-	2.15	2.5	V	$P_o=5\text{mW}$
Differential efficiency	$\eta$	0.5	0.75	1.0	mW/mA	$P_o=3\text{--}5\text{mW}$
Monitor current	$I_m$	0.05	0.1	0.3	mA	$P_o=5\text{mW}, V_{RD}=5\text{V}$
Parallel divergence angle	$\theta_{  }$	6	8	10	deg	
Perpendicular divergence angle	$\theta_{\perp}$	24	28	35	deg	
Parallel FFP deviation angle	$\Delta\theta_{  }$	-3	0	+3	deg	$P_o=5\text{mW}$
Perpendicular FFP deviation angle	$\Delta\theta_{\perp}$	-3	0	+3	deg	
Emission point accuracy	$\Delta x \Delta y \Delta z$	-80	0	+80	um	

### • Precautions

- \* Do not operate the device above maximum ratings. Doing so may cause unexpected and permanent damage to the device.
- \* Take precautions to avoid electrostatic discharge and/or momentary power spikes. A change in the characteristics of the laser or premature failure may result.
- \* Proper heat sinking of the device assures stability and lifetime. Always ensure that maximum operating temperatures are not exceeded.
- \* Observing visible or invisible laser beams with the human eye directly, or indirectly, can cause permanent damage. Use a camera to observe the laser.
- \* No laser device should be used in any application or situation where life or property is at risk in event of device failure.
- \* Specifications are subject to change without notice. Ensure that you have the latest specification by contacting us prior to purchase or use of the product.

\* For reference only. Contents above are subject to change without notice.

# AlGaInP Visible Laser Diode

## ADL-65053TL-2

DATE : 2006/6/30 Ver 1.0

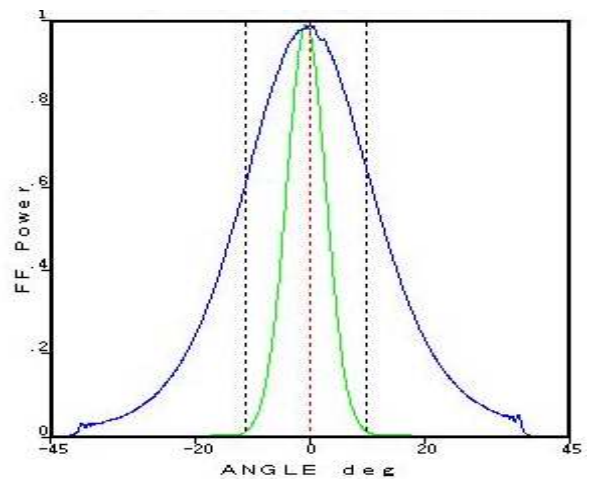
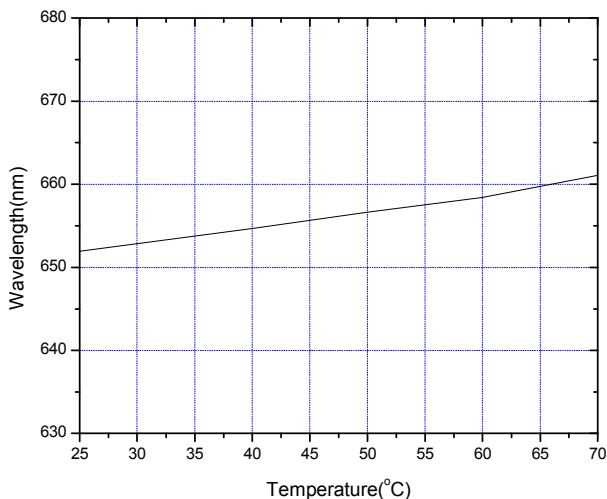
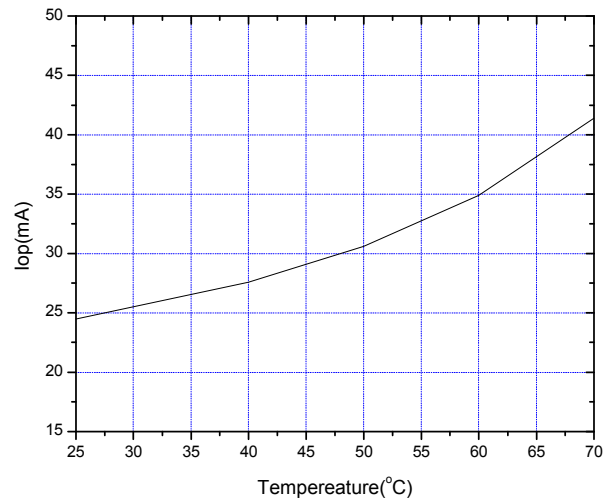
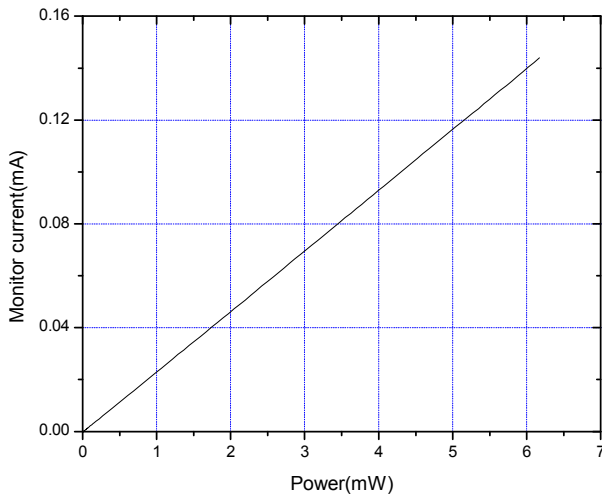
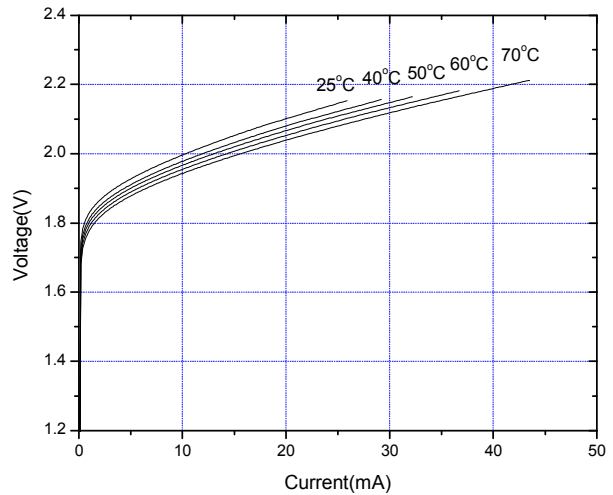
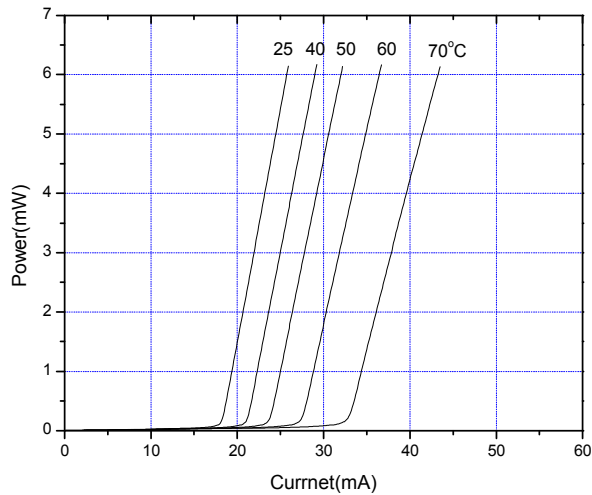

\* For reference only. Contents above are subject to change without notice.

[www.lasercomponents.com](http://www.lasercomponents.com)

01/08 / V2 / HW / ari/655nm/ adl-65053tl-2.pdf

Germany and other countries: LASER COMPONENTS GmbH, Phone: +49 8142 2864 0, Fax: +49 8142 2864 11, [info@lasercomponents.com](mailto:info@lasercomponents.com)

USA: LASER COMPONENTS IG, Inc., Phone: +1 603 821 7040, Fax: +1 603 821 7041, [info@laser-components.com](mailto:info@laser-components.com)

Great Britain: LASER COMPONENTS (UK) Ltd., Phone: +44 1245 491 499, Fax: +44 1245 491 801, [info@lasercomponents.co.uk](mailto:info@lasercomponents.co.uk)

France: LASER COMPONENTS S.A.S., Phone: +33 1 3959 5225, Fax: +33 1 3959 5350, [info@lasercomponents.fr](mailto:info@lasercomponents.fr)

**Arima**  
LASERS