

SM67-3N001

Multi-Mode 670nm VCSEL Chip

Features

- : 670nm wavelength range
- : Operating to over 50 °C
- : Low current and voltage
- : High reliability
- : Other configurations available on request

Applications

- : Consumer Electronics
- : Position Sensors
- : Medical Instruments
- : Home Networking
- : Data Link Communication, IEEE1394b
- : Low power consumption application
such as battery-operated equipment

Description

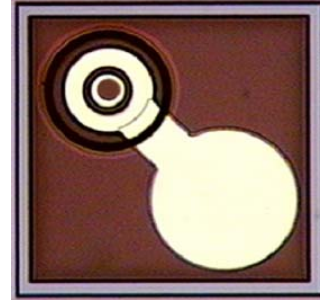

Absolute Maximum Ratings

Parameter	Rating
Storage Temperature	-40 to 85 °C
Operating Temperature	-20 to 50 °C
Lead Solder Temperature	260 °C, 10 sec
Continuous Forward Current	8 mA
Continuous Reverse Voltage	5V (@10µA)

Dimensions

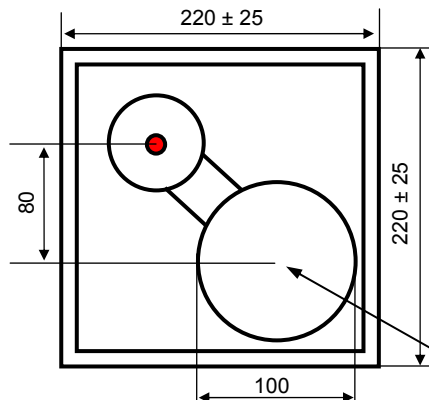

Unit: µm

Die Height: 200±15 µm

Anode Bonding Pad (Φ 100 µm)

Electro-Optics Characteristics ($T_a=25^{\circ}\text{C}$ unless otherwise stated)

Parameters	Symbol	Specified			Unit	Test Conditions
		Min.	Typ.	Max.		
Threshold Current	I_{th}		2	3.5	mA	CW
Slope Efficiency	η	0.2	0.4		W/A	$I_f = 5\text{mA}$
Optical Output Power	P_o		1.0		mW	$I_f = 5\text{mA}$
Peak Wavelength	λ	660	670	690	nm	$I_f = 5\text{mA}$
Spectral Bandwidth (RMS)	$\Delta \lambda$			0.85	nm	$I_f = 5\text{mA}$
Beam Divergence	Θ	14		30	°	$P_o=1.0\text{mW}$, (Full Width, $1/e^2$)
Operating Voltage	V_f		2.1	2.5	V	$I_f = 5\text{mA}$
Dynamic Resistance	R_d		60	80	Ohm	$I_f = 5\text{mA}$

Thermal Characteristics

Parameters	Symbol	Min.	Typ.	Max.	Unit	Test Conditions
Max. Operating Temperature	$P_{T=50^{\circ}\text{C}}$		0.5		mW	$T_a = 50^{\circ}\text{C}$, 5mA
Optical Output Power						
I_{th} Temperature Variation	ΔI_{th}		1.5		mA	$T_a = -20$ to 50°C
η Temperature Variation	$\Delta \eta / \Delta T$		-0.8		%/°C	$T_a = -20$ to 50°C at 5mA
λ Temperature Variation	$\Delta \lambda / \Delta T$		0.05		nm/°C	$T_a = -20$ to 50°C at 5mA

Notes

* These specifications are subject to change without notice.

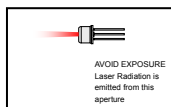
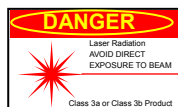

NOTICE

The inherent design of this component causes it to be sensitive to electrostatic discharge(ESD). To prevent ESD-induced damage and/or degradation to equipment, take normal ESD precautions when handling this product

DANGER

The VCSEL is a class IIIb laser and should be treated as a potential eye hazard. Due to the size of the component, the applicable warning logotype, aperture label, and certification / identification label cannot be placed on the component itself.

Characteristics Curves

LIV Curve

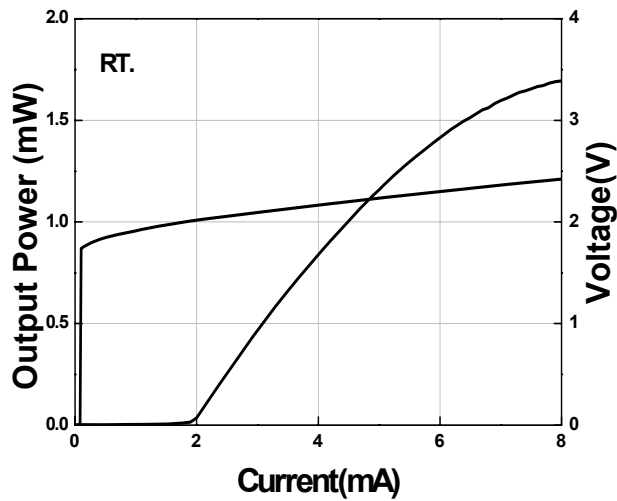

LIV vs Temperature

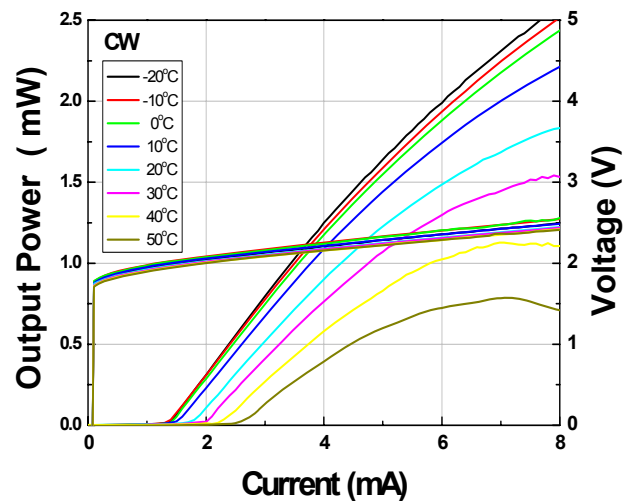

I_{th} vs Temperature

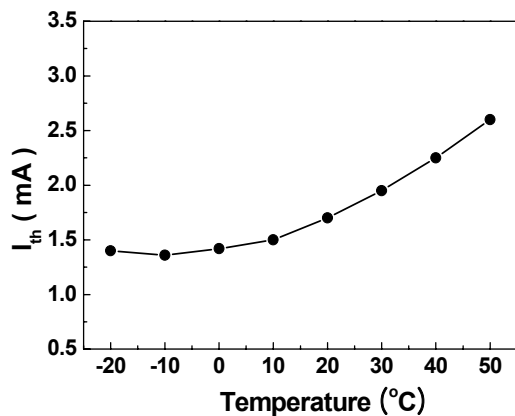

P_o vs Temperature

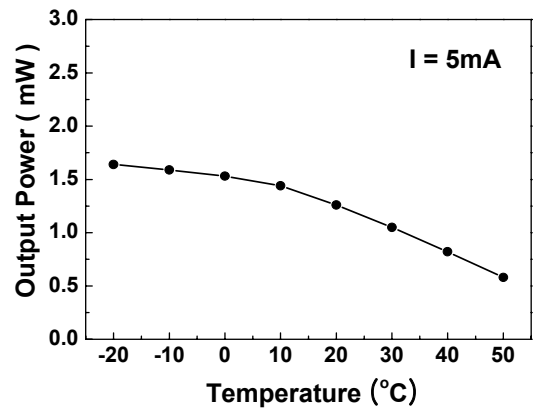

Far Field Pattern

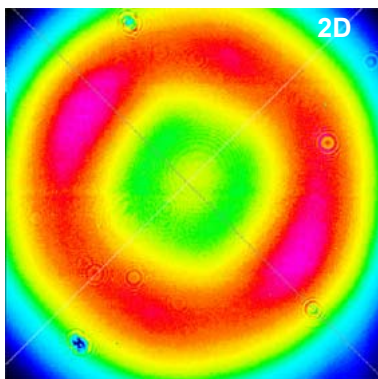

5mA. RT

