

single channel; TO18 housing; small chip size; JFET; current mode; feedback 1GOhm;

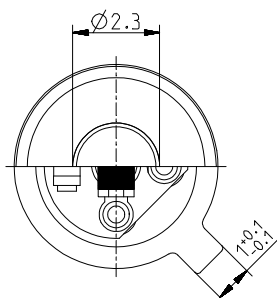

**HOUSING: PIN ASSIGNMENT:**

TO18 4Pin  
Bottom view

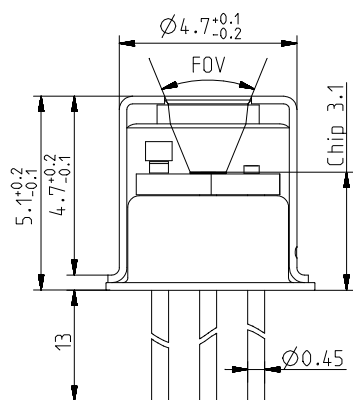
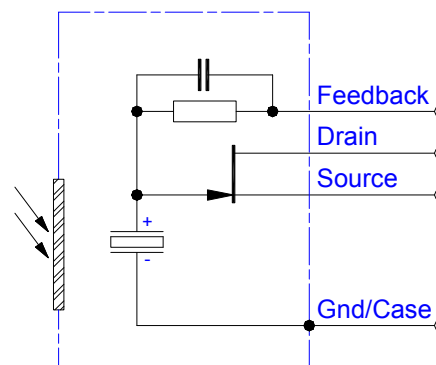
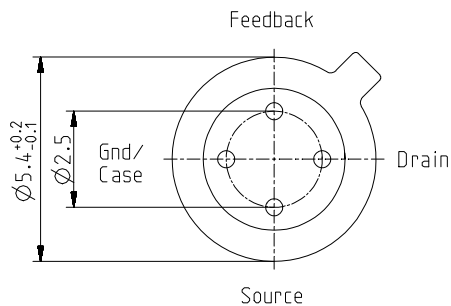

Top view

**FREQUENCY RESPONSE:**

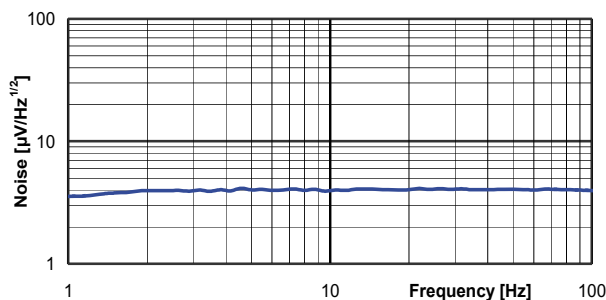
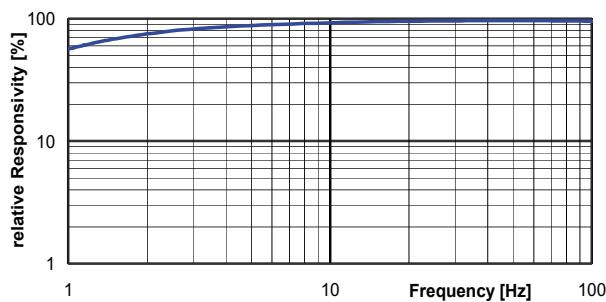

## TEST CIRCUIT:

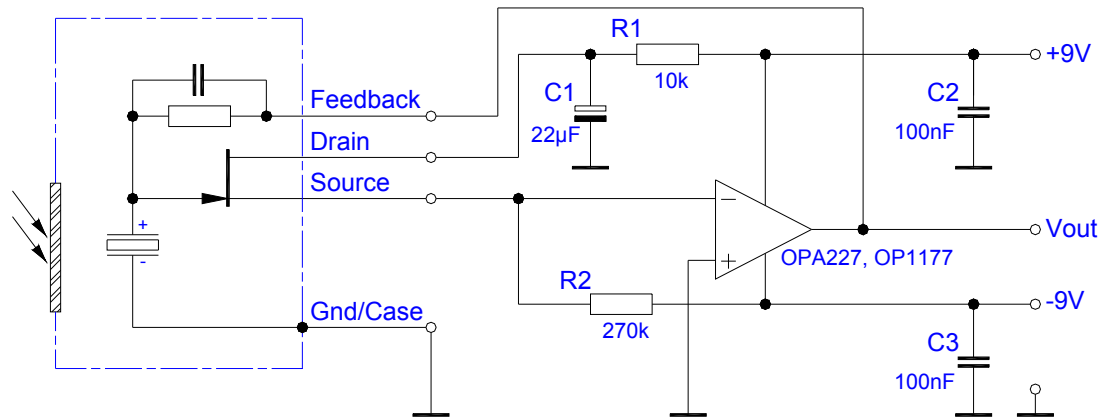

## PARAMETERS:

Aperture size	nom	ø2.3 mm
Element size / type	nom	1.4x1.0 mm <sup>2</sup> lithium-tantalate with black layer
Thermal time constant	typ	150 ms
Feedback resistor	nom	1 GOhm ±10%
Feedback capacitor	nom	470±100 fF
Polarity	nom	negative signal by positive IR flux change
Voltage responsivity (rms) {500K, 10 Hz, 25 °C, without window}	min	1,400 V/W
Noise density (rms) {10 Hz, BW 1 Hz, 25 °C}	max	5.0 µV/(sqrt[Hz])
Detectivity {500K, 10 Hz, 1 Hz, 25 °C, without window}	min	3.3E+07 cm(sqrt[Hz])/W
Offset voltage {opt. Drain current = 10 ... 100µA}	nom	-0.4 ... -1.5 V
Drain source voltage	max	18 V
Operating / Storage temperature	nom	-25 ... +85°C
IR window		All InfraTec windows and filters are available (except KBr and CsI). Customized filters upon request.
Filter sizes	nom	rectangular filters: (2.70 x 2.70) mm +0/-0.05 mm circular filters: ø3.3 mm ±0.1 mm standard thickness: 0.50 mm +0.2/-0.1 mm
Field of View	min	CaF <sub>2</sub> or BaF <sub>2</sub> ; 0.4 mm thick: 40° Silicon substrate; 0.5 mm thick: 45°