

LFP-80105-337

pyroelectric detector with tunable FPF

Description: **PROTOTYPE**

variable color; TO8 housing; medium chip size; thermal compensation; low Micro; OpAmp; current mode; feedback 100GOhm; integrated $\varnothing 1.9$ mm micromachined tunable Fabry-Perot filter. tuning range 8.0 ... 10.5 μm , spectral band width 150 nm, advanced transimpedance amplifier (TIA) for 1 Hz to 100 Hz modulation frequency range

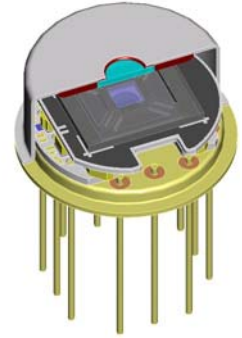

InfraTec Part number: **S85468**

HOUSING:

PIN ASSIGNMENT:

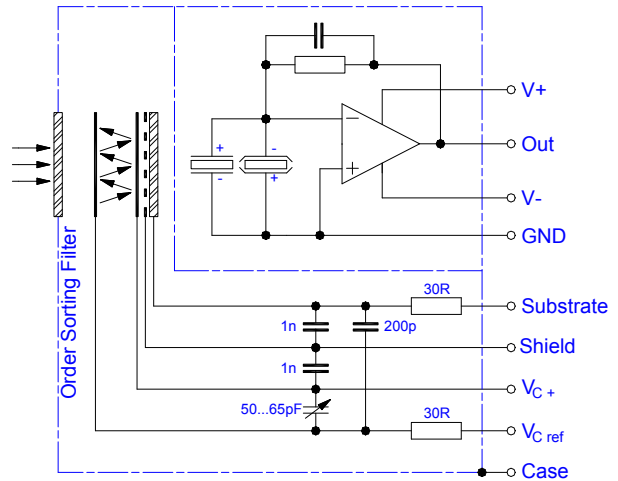
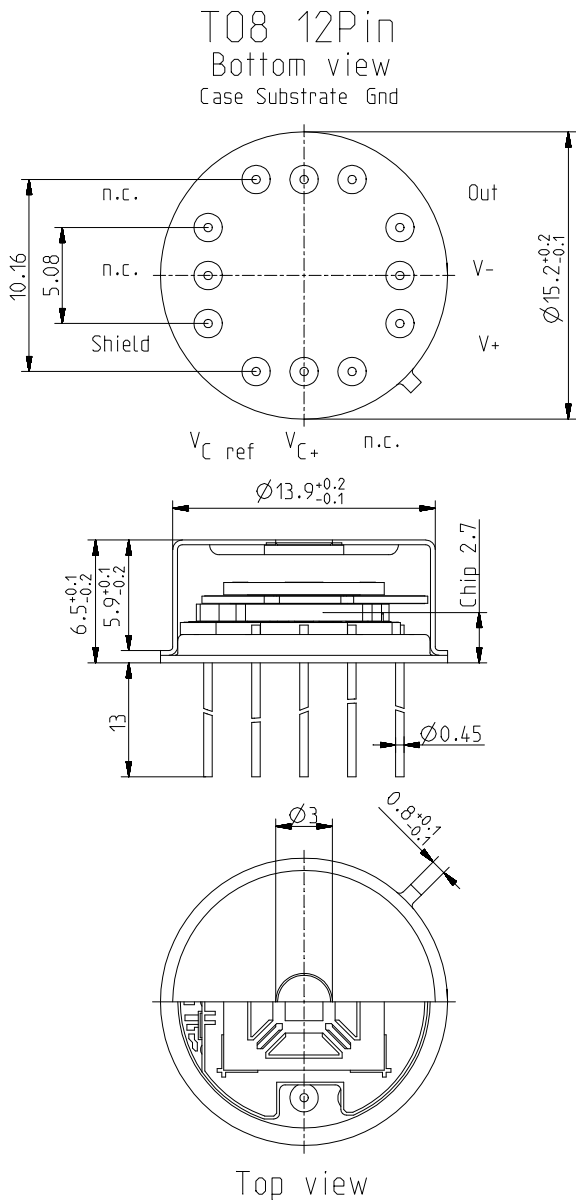

FREQUENCY RESPONSE:

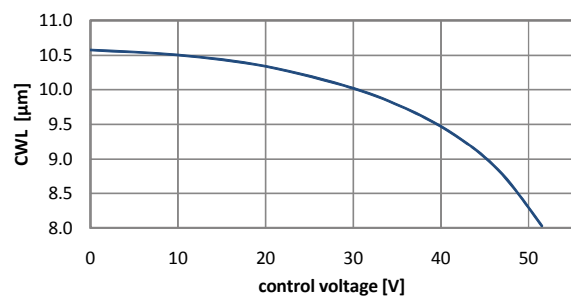
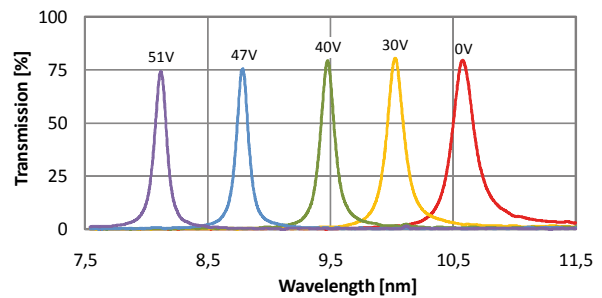

PRELIMINARY

LFP-80105-337

pyroelectric detector with tunable FPF

TEST CIRCUIT:

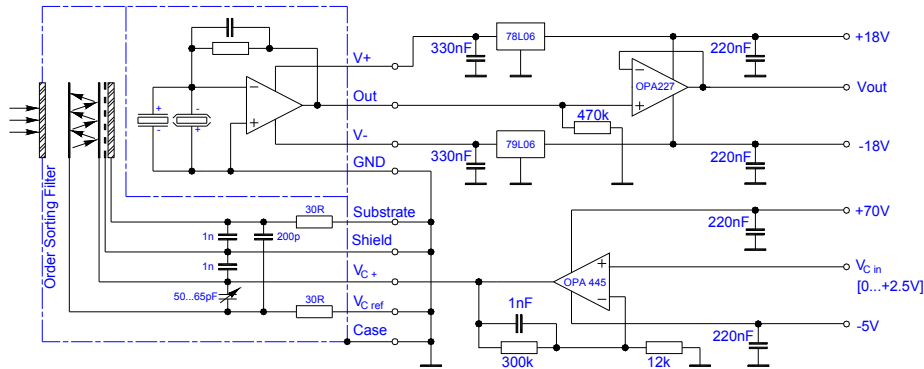

PARAMETERS:

Fabry-Perot filter	nom	FPF 8.0 ... 10.5 μm
Filter aperture size		$\varnothing 1.9 \text{ mm}$
Mirror drive mechanism	nom	electrostatic, 1 nF load, <0.05 μA leakage current
Guaranteed tuning range	nom	8.0 ... 10.5 μm
Spectral bandwidth @ 50% of transmission peak	nom	150 nm $\pm 30 \text{ nm}$
Control voltage $V_{c+} - V_{c \text{ ref}}$ @ 8.0 μm	typ	+50 V (max +65 V)
Allowable control voltage (limited by pull-in effect)	max	(control voltage @ 8.0 μm) + 1.0 V
Settling time (from 10.5 μm to 8.0 μm by control voltage step; $\pm 1 \text{ nm}$)	max	500ms
Order sorting filter	nom	WBP
Out of band blocking UV to	min	17 μm
Pyroelectric detector	nom	LME-337 based type
Element size / type	nom	2.0x2.0 mm ² lithium-tantalate with black layer
Thermal time constant	typ	150 ms
Feedback resistor	nom	100 GOhm $\pm 20\%$
Feedback capacitor	nom	50 fF $\pm 10 \text{ fF}$
Polarity	nom	negative signal by positive IR flux change
Voltage responsivity (rms) {400°C, 10 Hz, 25 °C} @ $V_{c+}=0\text{V}$, MgF2 long wavelength blocking	typ	1,000 V/W
Noise density (rms) {10 Hz, BW 1 Hz, 25 °C}	max	65 $\mu\text{V}/(\sqrt{\text{Hz}})$
Detectivity {400°C, 10 Hz, 1 Hz, 25 °C} @ $V_{c+}=0\text{V}$, MgF2 long wavelength blocking	typ	3.5E+ 06 cm($\sqrt{\text{Hz}}$)/W
CMOS operational amplifier	nom	OpAmp2
Supply voltage $V_{+} - V_{-}$	max	16 V
Operating supply voltage V_{+} / V_{-}		+2.2 ... 8.0 V / -2.2 ... -8.0 V
Recommended supply voltage V_{+} / V_{-}	nom	$V_{+} = +5 \text{ V}; V_{-} = -5 \text{ V}$
Supply current {output load 1MOhm}	max	150 μA
Offset voltage {25 °C; output load 1MOhm}		-5 mV ... +5 mV
Optimal output load	nom	330 kOhm
Absolute output current max		$\pm 0.4 \text{ mA}$
Operating / Storage temperature	nom	-25 ... +85°C
* Spectral measurement conditions		FTIR (resolution 4/cm; divergence angle $\pm 4^\circ$; AOI 0°)

© InfraTec GmbH, April 1st 2010