

Indium Gallium Arsenide Detectors

ISO 9001 Certified

J22 and J23 Detector Operating Notes (0.8 to 2.6 μm)

General

The J22 and J23 series are high performance InGaAs detectors operating over the spectral range from 0.8 μm to 2.6 μm . These detectors provide fast rise time, uniformity of response, excellent sensitivity, and long term reliability for a wide range of applications. For enhanced performance or temperature stability of response near the cutoff wavelength, Judson offers a variety of thermoelectrically cooled detector options.

Device Options

Judson's standard InGaAs detectors, the J22 series, offers high reliability and performance in the spectral range from 0.8 μm to 1.7 μm . In addition, the J23 series extended InGaAs detectors are available in four cutoff options at 1.9 μm , 2.2 μm , 2.4 μm and 2.6 μm . Figure 1 shows the typical response for the J22 and J23 series at room temperature operation.

Package Options

The J22 and J23 series are available in standard TO packages, ceramic sub-mounts, and bare die. We also offer different window materials, lenses or optical filter options. Please refer to pages 6 and 7 for package drawing examples.

For more demanding applications, Judson's team of engineers will provide custom design services. Please contact us with your special requirements

Accessories

For a complete system, Judson offers low noise transimpedance amplifier modules, heat sink/preamp assemblies and temperature controllers. For further details, please visit our website.

Call us

Let our team of application engineers assist you in selecting the best detector design for your application. Or visit our website for additional information on all of Judson's products.



Applications

- Gas analysis
- NIR-FTIR
- Raman spectroscopy
- IR fluorescence
- Blood analysis
- Optical sorting
- Radiometry
- Chemical detection
- Optical communication
- Optical power monitoring
- Laser diode monitoring
- Laser burn-in

Figure 1. Responsivity vs. Wavelength for InGaAs @ 22°C

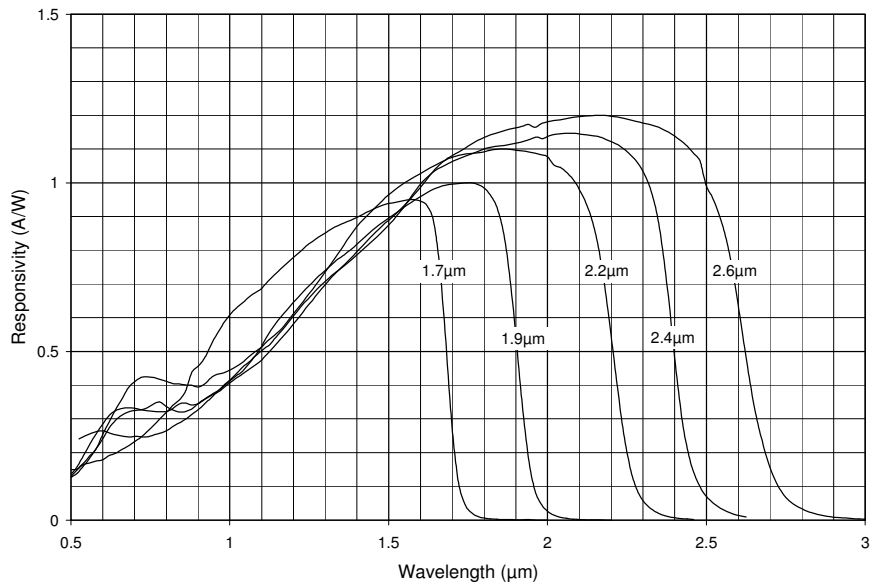

Typical Specification @ 22 °C

Detector Model Number	Active Size Diameter (mm)	50% Cutoff Wavelength* (μm)	Peak Wavelength* (μm)	Peak Responsivity (A/W) min	Shunt Impedance (Ohm)		Dark Current (A) @ Vr (max)		Peak D* (cmHz ^{1/2} /W) @ 1KHz		NEP (W/rt-Hz) @ peak wavelength	
					min	typ	typ	max	min	typ	max	typ
J22-181-R40U	0.040	1.7+/-0.1	1.65+/-0.10	0.90	4.0E+08	1.5E+09	3.0E-11	3.0E-10	5.0E+11	1.0E+12	7.1E-15	3.5E-15
J22-181-R75U	0.075				2.5E+08	1.0E+09	4.0E-11	4.0E-10	7.4E+11	1.5E+12	9.0E-15	4.5E-15
J22-181-R250U	0.250				1.5E+08	6.0E+08	1.0E-10	1.0E-09	1.9E+12	3.8E+12	1.2E-14	5.8E-15
J22-181-R500U	0.500				5.0E+07	2.0E+08	2.5E-10	2.5E-09	2.2E+12	4.4E+12	2.0E-14	1.0E-14
J22-181-R01M	1.000				1.5E+07	6.0E+07	1.0E-09	1.0E-08	2.4E+12	4.8E+12	3.7E-14	1.8E-14
J22-5I-R02M	2.000				4.0E+06	1.6E+07	4.0E-09	4.0E-08	2.5E+12	5.0E+12	7.1E-14	3.5E-14
J23-181-R250U-1.9	0.25	1.9+/-0.1	1.75+/-0.10	1.00	8.0E+06	1.6E+07	1.0E-08	1.0E-07	4.9E+11	6.9E+11	4.5E-14	3.2E-14
J23-181-R500U-1.9	0.50				2.6E+06	5.2E+06	3.0E-08	3.0E-07	5.6E+11	7.9E+11	7.9E-14	5.6E-14
J23-181-R01M-1.9	1.00				8.0E+05	1.6E+06	1.0E-07	1.0E-06	6.2E+11	8.8E+11	1.4E-13	1.0E-13
J23-5I-R02M-1.9	2.00				1.5E+05	3.0E+05	4.0E-07	4.0E-06	5.4E+11	7.6E+11	3.3E-13	2.3E-13
J23-5I-R03M-1.9	3.00				4.5E+04	9.0E+04	1.0E-06	1.0E-05	4.4E+11	6.3E+11	6.0E-13	4.3E-13
J23-181-R250U-2.2	0.25	2.2+/-0.1	1.90+/-0.10	1.10	5.0E+05	1.0E+06	1.0E-07	1.0E-06	1.4E+11	1.9E+11	1.6E-13	1.2E-13
J23-181-R500U-2.2	0.50				1.7E+05	3.4E+05	3.0E-07	3.0E-06	1.6E+11	2.2E+11	2.8E-13	2.0E-13
J23-181-R01M-2.2	1.00				5.0E+04	1.0E+05	1.0E-06	1.0E-05	1.7E+11	2.4E+11	5.2E-13	3.7E-13
J23-5I-R02M-2.2	2.00				1.0E+04	2.0E+04	4.0E-06	4.0E-05	1.5E+11	2.2E+11	1.2E-12	8.2E-13
J23-5I-R03M-2.2	3.00				3.0E+03	6.0E+03	1.0E-05	1.0E-04	1.3E+11	1.8E+11	2.1E-12	1.5E-12
J23-181-R250U-2.4	0.25	2.4+/-0.1	2.15+/-0.10	1.15	1.0E+05	2.0E+05	3.5E-07	3.5E-06	6.3E+10	8.9E+10	3.5E-13	2.5E-13
J23-181-R500U-2.4	0.50				3.3E+04	6.6E+04	1.0E-06	1.0E-05	7.3E+10	1.0E+11	6.1E-13	4.3E-13
J23-181-R01M-2.4	1.00				1.0E+04	2.0E+04	3.5E-06	3.5E-05	8.0E+10	1.1E+11	1.1E-12	7.8E-13
J23-5I-R02M-2.4	2.00				2.0E+03	4.0E+03	1.5E-05	1.5E-04	7.1E+10	1.0E+11	2.5E-12	1.8E-12
J23-5I-R03M-2.4	3.00			6.5E+02	1.3E+03	3.5E-05	3.5E-04	5.8E+10	8.3E+10	4.6E-12	3.2E-12	
J23-181-R250U-2.6	0.25	2.6+/-0.1	2.25+/-0.10	1.20	2.5E+04	5.0E+04	1.0E-06	1.0E-05	3.3E+10	4.7E+10	6.7E-13	4.8E-13
J23-181-R500U-2.6	0.50				8.0E+03	1.6E+04	3.0E-06	3.0E-05	3.7E+10	5.3E+10	1.2E-12	8.4E-13
J23-181-R01M-2.6	1.00				2.5E+03	5.0E+03	1.0E-05	1.0E-04	4.2E+10	5.9E+10	2.1E-12	1.5E-12
J23-5I-R02M-2.6	2.00				5.0E+02	1.0E+03	4.0E-05	4.0E-04	3.7E+10	5.3E+10	4.8E-12	3.4E-12
J23-5I-R03M-2.6	3.00			1.6E+02	3.2E+02	1.0E-04	1.0E-03	2.9E+10	4.1E+10	9.2E-12	6.5E-12	

* Tighter tolerance for cutoff and peak wavelengths may be available upon customer request. All specifications are for detector operation at 0V bias and 22C unless otherwise specified.

1.7μm Cutoff Thermoelectrically Cooled InGaAs Detectors

Detector Model Number	Active Size Diameter (mm)	Operating Temp. (°C)	50% Cutoff Wavelength (μm)	Responsivity @ 1.55μm (A/W) min	Shunt Impedance (Ohm)		Peak D* (Jones)		NEP (W/rt-Hz) @ peak wavelength		Capacitance (pF) @ 0V typ
					min	typical	min	typ	max	typ	
J22TE1-66C-R01M	1	-20	1.63	0.9	7.5E+08	3.0E+09	1.8E+13	3.7E+13	4.8E-15	2.4E-15	125
J22TE1-66C-R02M	2	-20	1.63	0.9	1.8E+08	7.2E+08	1.8E+13	3.6E+13	9.8E-15	4.9E-15	500
J22TE1-66C-R03M	3	-20	1.63	0.9	6.5E+07	2.6E+08	1.6E+13	3.3E+13	1.6E-14	8.1E-15	1200
J22TE1-66C-R05M	5	-20	1.63	0.9	2.0E+07	8.0E+07	1.5E+13	3.0E+13	2.9E-14	1.5E-14	3200
J22TE2-66C-R01M	1	-40	1.62	0.9	5.0E+09	2.0E+10	5.0E+13	9.9E+13	1.8E-15	8.9E-16	125
J22TE2-66C-R02M	2	-40	1.62	0.9	1.1E+09	4.4E+09	4.7E+13	9.3E+13	3.8E-15	1.9E-15	500
J22TE2-66C-R03M	3	-40	1.62	0.9	4.0E+08	1.6E+09	4.2E+13	8.4E+13	6.3E-15	3.2E-15	1200
J22TE2-66C-R05M	5	-40	1.62	0.9	1.2E+08	4.8E+08	3.9E+13	7.7E+13	1.2E-14	5.8E-15	3200

All specifications are for detector operation at 0V bias and 22C unless otherwise specified.

1.9µm Cutoff Thermoelectrically Cooled Extended InGaAs Detectors

Detector Model Number	Active Size Diameter (mm)	Operating Temp. (°C)	50% Cutoff Wavelength* (µm)	Peak Responsivity (A/W) min	Shunt Impedance (Ohm)		Peak D* (cmHz ^{1/2} /W) @ 1KHz		NEP (W/rt-Hz) @ peak wavelength		Capacitance (pF) @ 0V typ
					min	typ	min	typ	max	typ	
J23TE1-66C-R250U-1.9	0.25	-20	1.85+/-0.10	1.0	2.8E+08	5.6E+08	3.1E+12	4.4E+12	7.1E-15	5.0E-15	75
J23TE1-66C-R500U-1.9	0.50				1.0E+08	2.0E+08	3.7E+12	5.3E+12	1.2E-14	8.4E-15	250
J23TE1-66C-R01M-1.9	1.00				3.0E+07	6.0E+07	4.1E+12	5.8E+12	2.2E-14	1.5E-14	1000
J23TE1-66C-R02M-1.9	2.00				5.5E+06	1.1E+07	3.5E+12	5.0E+12	5.0E-14	3.6E-14	4000
J23TE1-66C-R03M-1.9	3.00				1.5E+06	3.0E+06	2.8E+12	3.9E+12	9.6E-14	6.8E-14	9000
J23TE2-66C-R250U-1.9	0.25	-40	1.83+/-0.10	1.0	1.4E+09	2.8E+09	7.3E+12	1.0E+13	3.0E-15	2.1E-15	75
J23TE2-66C-R500U-1.9	0.50				5.2E+08	1.0E+09	8.9E+12	1.3E+13	5.0E-15	3.5E-15	250
J23TE2-66C-R01M-1.9	1.00				1.6E+08	3.2E+08	9.9E+12	1.4E+13	9.0E-15	6.3E-15	1000
J23TE2-66C-R02M-1.9	2.00				2.6E+07	5.2E+07	8.0E+12	1.1E+13	2.2E-14	1.6E-14	4000
J23TE2-66C-R03M-1.9	3.00				7.5E+06	1.5E+07	6.4E+12	9.1E+12	4.1E-14	2.9E-14	9000
J23TE3-66C-R250U-1.9	0.25	-65	1.82+/-0.10	1.0	8.0E+09	1.6E+10	1.8E+13	2.6E+13	1.2E-15	8.5E-16	75
J23TE3-66C-R500U-1.9	0.50				3.5E+09	7.0E+09	2.4E+13	3.5E+13	1.8E-15	1.3E-15	250
J23TE3-66C-R01M-1.9	1.00				1.2E+09	2.4E+09	2.9E+13	4.1E+13	3.1E-15	2.2E-15	1000
J23TE3-66C-R02M-1.9	2.00				1.7E+08	3.4E+08	2.2E+13	3.1E+13	8.2E-15	5.8E-15	4000
J23TE3-66C-R03M-1.9	3.00				4.0E+07	8.0E+07	1.6E+13	2.2E+13	1.7E-14	1.2E-14	9000
J23TE4-3CN-R250U-1.9	0.25	-85	1.81+/-0.10	1.0	3.2E+10	6.4E+10	3.9E+13	5.5E+13	5.7E-16	4.0E-16	75
J23TE4-3CN-R500U-1.9	0.50				1.6E+10	3.2E+10	5.5E+13	7.8E+13	8.1E-16	5.7E-16	250
J23TE4-3CN-R01M-1.9	1.00				6.0E+09	1.2E+10	6.7E+13	9.5E+13	1.3E-15	9.3E-16	1000
J23TE4-3CN-R02M-1.9	2.00				7.0E+08	1.4E+09	4.6E+13	6.5E+13	3.9E-15	2.7E-15	4000
J23TE4-3CN-R03M-1.9	3.00				1.5E+08	3.0E+08	3.2E+13	4.5E+13	8.3E-15	5.9E-15	9000

* Tighter tolerance for cutoff and peak wavelengths may be available upon customer request. All specifications are for detector operation at 0V bias and 22C unless otherwise specified.

2.2µm Cutoff Thermoelectrically Cooled Extended InGaAs Detectors

Detector Model Number	Active Size Diameter (mm)	Operating Temp. (°C)	50% Cutoff Wavelength* (µm)	Peak Responsivity (A/W) min	Shunt Impedance (Ohm)		Peak D* (cmHz ^{1/2} /W) @ 1KHz		NEP (W/rt-Hz) @ peak wavelength		Capacitance (pF) @ 0V typ
					min	typ	min	typ	max	typ	
J23TE1-66C-R250U-2.2	0.25	-20	2.14+/-0.10	1.1	1.1E+07	2.2E+07	6.8E+11	9.7E+11	3.2E-14	2.3E-14	75
J23TE1-66C-R500U-2.2	0.50				4.0E+06	8.0E+06	8.2E+11	1.2E+12	5.4E-14	3.8E-14	250
J23TE1-66C-R01M-2.2	1.00				1.2E+06	2.4E+06	9.0E+11	1.3E+12	9.8E-14	6.9E-14	1000
J23TE1-66C-R02M-2.2	2.00				2.2E+05	4.4E+05	7.7E+11	1.1E+12	2.3E-13	1.6E-13	4000
J23TE1-66C-R03M-2.2	3.00				6.2E+04	1.2E+05	6.2E+11	8.7E+11	4.3E-13	3.1E-13	9000
J23TE2-66C-R250U-2.2	0.25	-40	2.11+/-0.10	1.1	4.8E+07	9.6E+07	1.5E+12	2.1E+12	1.5E-14	1.1E-14	75
J23TE2-66C-R500U-2.2	0.50				1.8E+07	3.6E+07	1.8E+12	2.6E+12	2.4E-14	1.7E-14	250
J23TE2-66C-R01M-2.2	1.00				5.5E+06	1.1E+07	2.0E+12	2.9E+12	4.4E-14	3.1E-14	1000
J23TE2-66C-R02M-2.2	2.00				9.5E+05	1.9E+06	1.7E+12	2.4E+12	1.1E-13	7.5E-14	4000
J23TE2-66C-R03M-2.2	3.00				2.6E+05	5.2E+05	1.3E+12	1.9E+12	2.0E-13	1.4E-13	9000
J23TE3-66C-R250U-2.2	0.25	-65	2.09+/-0.10	1.1	2.6E+08	5.2E+08	3.7E+12	5.2E+12	6.0E-15	4.3E-15	75
J23TE3-66C-R500U-2.2	0.50				1.1E+08	2.2E+08	4.8E+12	6.7E+12	9.3E-15	6.6E-15	250
J23TE3-66C-R01M-2.2	1.00				3.5E+07	7.0E+07	5.4E+12	7.6E+12	1.6E-14	1.4E-14	1000
J23TE3-66C-R02M-2.2	2.00				5.5E+06	1.1E+07	4.3E+12	6.0E+12	4.2E-14	2.9E-14	4000
J23TE3-66C-R03M-2.2	3.00				1.3E+06	2.6E+06	3.1E+12	4.4E+12	8.5E-14	6.0E-14	9000
J23TE4-3CN-R250U-2.2	0.25	-85	2.07+/-0.10	1.1	9.5E+08	1.9E+09	7.4E+12	1.0E+13	3.0E-15	2.1E-15	75
J23TE4-3CN-R500U-2.2	0.50				4.5E+08	9.0E+08	1.0E+13	1.4E+13	4.4E-15	3.1E-15	250
J23TE4-3CN-R01M-2.2	1.00				1.5E+08	3.0E+08	1.2E+13	1.7E+13	7.6E-14	5.3E-14	1000
J23TE4-3CN-R02M-2.2	2.00				2.1E+07	4.2E+07	8.8E+12	1.2E+13	2.0E-14	1.4E-14	4000
J23TE4-3CN-R03M-2.2	3.00				4.5E+06	9.0E+06	6.1E+12	8.6E+12	4.4E-14	3.1E-14	9000

* Tighter tolerance for cutoff and peak wavelengths may be available upon customer request. All specifications are for detector operation at 0V bias and 22C unless otherwise specified.

2.4µm Cutoff Thermoelectrically Cooled Extended InGaAs Detectors

Detector Model Number	Active Size Diameter (mm)	Operating Temp. (°C)	50% Cutoff Wavelength* (µm)	Peak Responsivity (A/W) min	Shunt Impedance (Ohm)		Peak D* (cmHz ^{1/2} /W) @ 1KHz		NEP (W/rt-Hz) @ peak wavelength		Capacitance (pF) @ 0V typ
					min	typ	min	typ	max	typ	
J23TE1-66C-R250U-2.4	0.25	-20	2.34+/-0.10	1.15	2.7E+06	5.4E+06	3.5E+11	5.0E+11	6.3E-14	4.4E-14	75
J23TE1-66C-R500U-2.4	0.50				1.0E+06	2.0E+06	4.3E+11	6.1E+11	1.0E-13	7.3E-14	250
J23TE1-66C-R01M-2.4	1.00				3.0E+05	6.0E+05	4.7E+11	6.7E+11	1.9E-13	1.3E-13	1000
J23TE1-66C-R02M-2.4	2.00				5.0E+04	1.0E+05	3.9E+11	5.5E+11	4.6E-13	3.2E-13	4000
J23TE1-66C-R03M-2.4	3.00				1.5E+04	3.0E+04	3.2E+11	4.5E+11	8.4E-13	5.9E-13	9000
J23TE2-66C-R250U-2.4	0.25	-40	2.31+/-0.10	1.15	1.2E+07	2.4E+07	7.8E+11	1.1E+12	2.8E-14	2.0E-14	75
J23TE2-66C-R500U-2.4	0.50				4.5E+06	9.0E+06	9.5E+11	1.3E+12	4.6E-14	3.3E-14	250
J23TE2-66C-R01M-2.4	1.00				1.5E+06	3.0E+06	1.1E+12	1.6E+12	8.1E-14	5.7E-14	1000
J23TE2-66C-R02M-2.4	2.00				2.3E+05	4.6E+05	8.6E+11	1.2E+12	2.1E-13	1.5E-13	4000
J23TE2-66C-R03M-2.4	3.00				6.3E+04	1.3E+05	6.8E+11	9.6E+11	3.9E-13	2.8E-13	9000
J23TE3-66C-R250U-2.4	0.25	-65	2.29+/-0.10	1.15	4.8E+07	9.6E+07	1.6E+12	2.3E+12	1.3E-14	9.5E-15	75
J23TE3-66C-R500U-2.4	0.50				2.2E+07	4.4E+07	2.2E+12	3.2E+12	2.0E-14	1.4E-14	250
J23TE3-66C-R01M-2.4	1.00				7.5E+06	1.5E+07	2.6E+12	3.7E+12	3.4E-14	2.4E-14	1000
J23TE3-66C-R02M-2.4	2.00				1.0E+06	2.0E+06	1.9E+12	2.7E+12	9.3E-14	6.6E-14	4000
J23TE3-66C-R03M-2.4	3.00				2.5E+05	5.0E+05	1.4E+12	2.0E+12	1.9E-13	1.3E-13	9000
J23TE4-3CN-R250U-2.4	0.25	-85	2.27+/-0.10	1.15	1.5E+08	3.0E+08	3.1E+12	4.3E+12	7.2E-15	5.1E-15	75
J23TE4-3CN-R500U-2.4	0.50				6.6E+07	1.3E+08	4.1E+12	5.7E+12	1.1E-14	7.7E-15	250
J23TE4-3CN-R01M-2.4	1.00				2.5E+07	5.0E+07	5.0E+12	7.1E+12	1.8E-14	1.3E-14	1000
J23TE4-3CN-R02M-2.4	2.00				3.1E+06	6.2E+06	3.5E+12	5.0E+12	5.0E-14	3.6E-14	4000
J23TE4-3CN-R03M-2.4	3.00				8.0E+05	1.6E+06	2.7E+12	3.8E+12	9.9E-14	7.0E-14	9000

* Tighter tolerance for cutoff and peak wavelengths may be available upon customer request. All specifications are for detector operation at 0V bias and 22C unless otherwise specified.

2.6µm Cutoff Thermoelectrically Cooled Extended InGaAs Detectors

Detector Model Number	Active Size Diameter (mm)	Operating Temp. (°C)	50% Cutoff Wavelength* (µm)	Peak Responsivity (A/W) min	Shunt Impedance (Ohm)		Peak D* (cmHz ^{1/2} /W) @ 1KHz		NEP (W/rt-Hz) @ peak wavelength		Capacitance (pF) @ 0V typ
					min	typ	min	typ	max	typ	
J23TE1-66C-R250U-2.6	0.25	-20	2.52+/-0.10	1.2	7.0E+05	1.4E+06	1.9E+11	2.7E+11	1.2E-13	8.3E-14	75
J23TE1-66C-R500U-2.6	0.50				2.6E+05	5.2E+05	2.3E+11	3.2E+11	1.9E-13	1.4E-13	250
J23TE1-66C-R01M-2.6	1.00				8.0E+04	1.6E+05	2.5E+11	3.6E+11	3.5E-13	2.5E-13	1000
J23TE1-66C-R02M-2.6	2.00				1.3E+04	2.6E+04	2.1E+11	2.9E+11	8.6E-13	6.1E-13	4000
J23TE1-66C-R03M-2.6	3.00				3.5E+03	7.0E+03	1.6E+11	2.3E+11	1.7E-12	1.2E-12	9000
J23TE2-66C-R250U-2.6	0.25	-40	2.48+/-0.10	1.2	3.0E+06	6.0E+06	4.1E+11	5.7E+11	5.5E-14	3.9E-14	75
J23TE2-66C-R500U-2.6	0.50				1.3E+06	2.6E+06	5.3E+11	7.6E+11	8.3E-14	5.9E-14	250
J23TE2-66C-R01M-2.6	1.00				4.0E+05	8.0E+05	5.9E+11	8.4E+11	1.5E-13	1.1E-13	1000
J23TE2-66C-R02M-2.6	2.00				6.0E+04	1.2E+05	4.6E+11	6.5E+11	3.9E-13	2.7E-13	4000
J23TE2-66C-R03M-2.6	3.00				1.5E+04	3.0E+04	3.4E+11	4.9E+11	7.7E-13	5.5E-13	9000
J23TE3-66C-R250U-2.6	0.25	-65	2.45+/-0.10	1.2	1.4E+07	2.8E+07	9.3E+11	1.3E+12	2.4E-14	1.7E-14	75
J23TE3-66C-R500U-2.6	0.50				6.0E+06	1.2E+07	1.2E+12	1.7E+12	3.6E-14	2.6E-14	250
J23TE3-66C-R01M-2.6	1.00				2.0E+06	4.0E+06	1.4E+12	2.0E+12	6.3E-14	4.5E-14	1000
J23TE3-66C-R02M-2.6	2.00				2.9E+05	5.8E+05	1.1E+12	1.5E+12	1.7E-13	1.2E-13	4000
J23TE3-66C-R03M-2.6	3.00				7.0E+04	1.4E+05	7.9E+11	1.1E+12	3.4E-13	2.4E-13	9000
J23TE4-3CN-R250U-2.6	0.25	-85	2.43+/-0.10	1.2	4.0E+07	8.0E+07	1.7E+12	2.3E+12	1.3E-14	9.5E-15	75
J23TE4-3CN-R500U-2.6	0.50				1.8E+07	3.6E+07	2.2E+12	3.1E+12	2.0E-14	1.4E-14	250
J23TE4-3CN-R01M-2.6	1.00				6.0E+06	1.2E+07	2.6E+12	3.6E+12	3.5E-14	2.5E-14	1000
J23TE4-3CN-R02M-2.6	2.00				8.5E+05	1.7E+06	1.9E+12	2.7E+12	9.2E-14	6.5E-14	4000
J23TE4-3CN-R03M-2.6	3.00				2.0E+05	4.0E+05	1.4E+12	2.0E+12	1.9E-13	1.3E-13	9000

* Tighter tolerance for cutoff and peak wavelengths may be available upon customer request. All specifications are for detector operation at 0V bias and 22C unless otherwise specified.

Standard Packages

66C Package: AR coated sapphire window

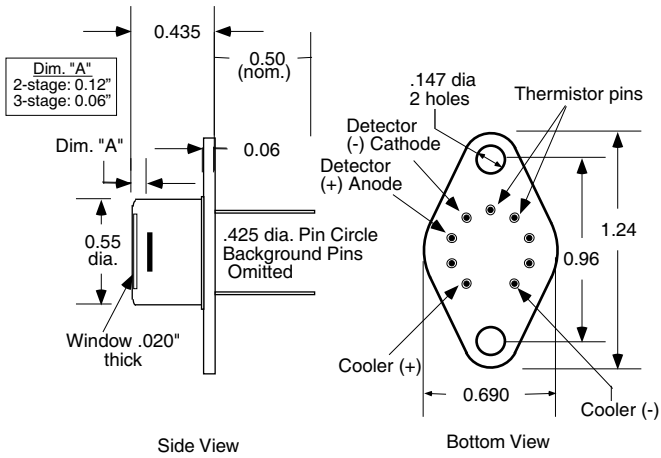

3CN Package

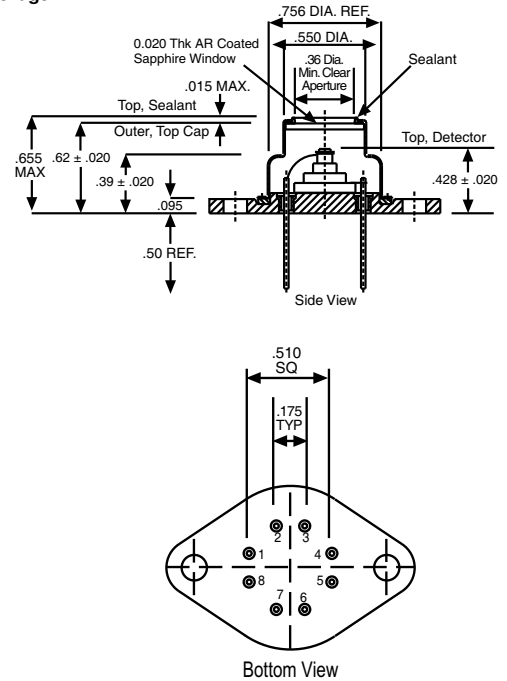

5I Package

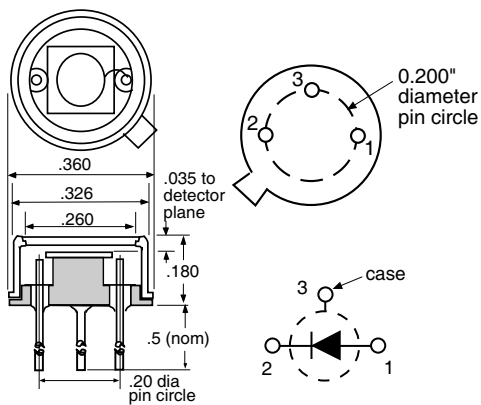

18I Package

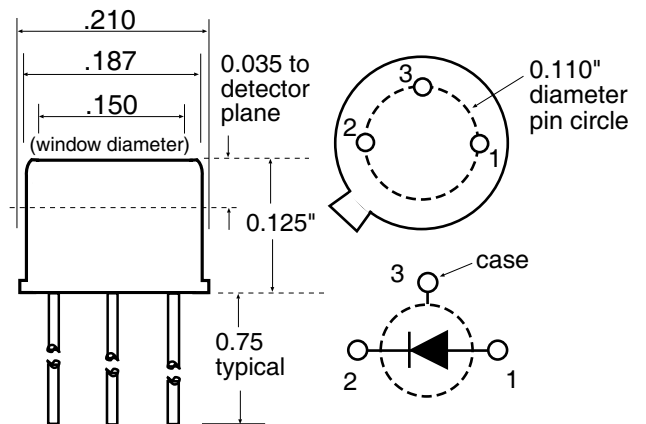

Optional Packages

C02 Package

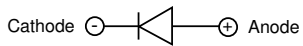
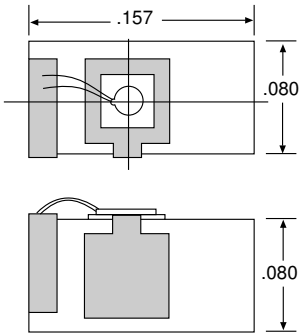

C11 Package

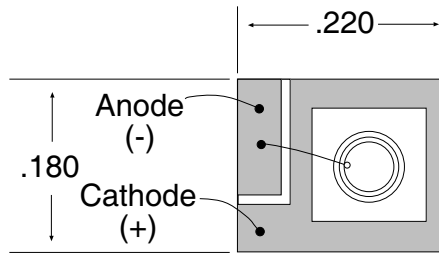

C12 Package

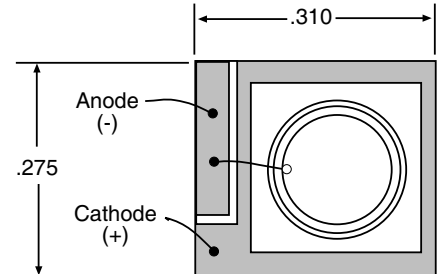

Note: .010 thick ceramic substrate used for both C11 and C12.

18D Package

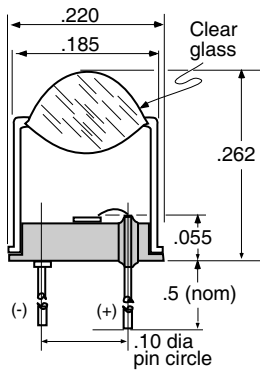

LD, LD2 Packages

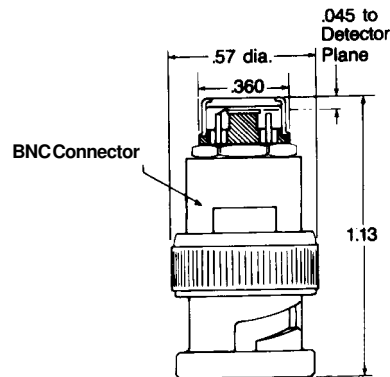
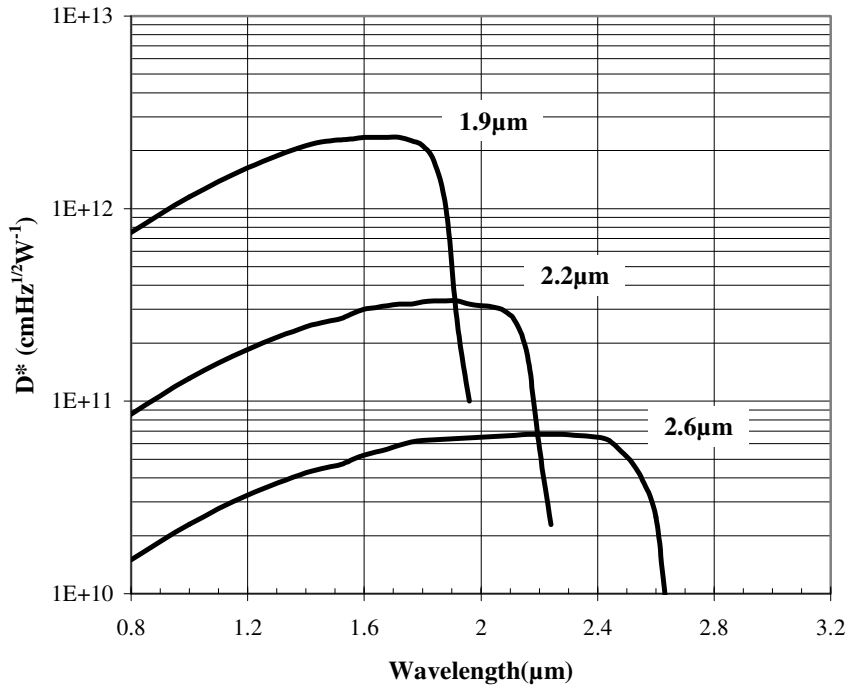
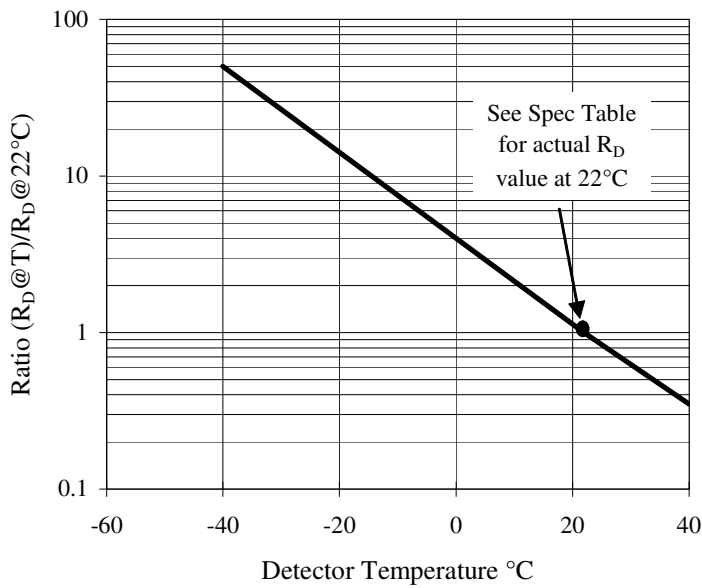

Figure 2
Typical D* vs Wavelength



Parameter	Min	Max	Units
Uniformity of Response @ Peak over Area (25°C)		±2	%
Storage Temperature	-55	+80	°C
Operating Temperature	-55	+60	°C

Figure 3
Typical Change in Shunt Resistance vs Temperature



InGaAs Arrays Parallel Output NIR Arrays (0.8 to 1.8 μm)

Description

Standard packaging and element configurations result in low cost and quick delivery for Judson's high-quality photodiode arrays.

The 16 and 32 element InGaAs arrays respond to infrared radiation from 700nm to 1.8 μm . The photodiode arrays come mounted in a dual in-line package.

Judson's NIR arrays have a parallel output format with common substrate and one pinout for each element. This format allows for independent readings from each channel.

A separate transimpedance op-amp circuit is recommended for each channel. The Judson Model PA-7:16C and PA-7:32C preamps are convenient multi-channel modules with receptacles for the array package. Transimpedance gain is specified by the user.

Applications

- Clinical Analyzers
- Near-IR Spectroscopy for Analysis of:
 - Protein
 - Blood Samples
 - Agricultural Products
- Fiber Optics:
 - Far-Field Laser Diode Pattern Analysis
 - Infrared Fiber Testing
- Currency Validation



Package

These arrays are mounted in the Judson "40P" package, a 40 pin, dual-in-line package with glass window (Fig. 9-1).

Pins 1 and 21 are connected to the common substrate. Elements of the 16-element array are connected to pins 23-38. The 32-element array is mounted with odd-numbered elements connected to pins 3-18 and even-numbered elements connected to pins 23-38.

The gap between elements is 0.01mm.

Figure 9-1

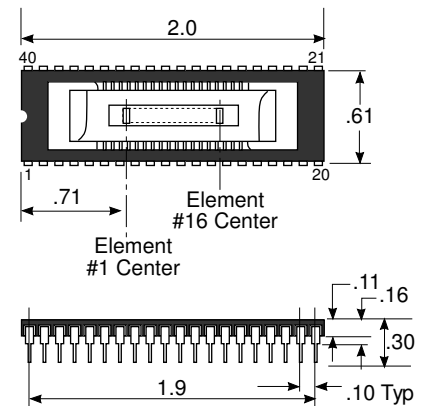

Typical Specifications Near IR Series Arrays

Detector Model Number	Active Size Diameter (mm)	Operating Temp. ($^{\circ}\text{C}$)	Operating Temp (K)	Peak Responsivity (A/W) min	Shunt impedance (Ohm)		Dark Current (A) @ Vr (max)		Peak D* (Jones)		NEP (W/rt-Hz) @ peak wavelength		Max Reverse Bias (V) typ	Capacitance (pF) @ 0V typ
					min	typical	typ	max	min	typ	max	typ		
J22P-40P-500Ux1M:XXE	0.5x1	22	295	0.9	2.00E+07	8.00E+07	5E-10	5E-09	2.23E+12	4.461E+12	3.17E-14	1.59E-14	3	70

XX = specs apply for both 16 and 32 element arrays

In addition to our Extended InGaAs product line, Judson Technologies offers a wide range of high performance standard, custom and space qualified detector products and accessories.

- Germanium detectors and arrays
- Indium Arsenide detectors and arrays
- Indium Antimonide detectors and arrays
- Mercury Cadmium Telluride detectors and arrays
- Photovoltaic Mercury Cadmium Telluride detectors and arrays
- Lead Selenide detectors and arrays
- Lead Sulfide detectors and arrays
- Dewars, backfill and vacuum packages
- Thermoelectric, Joule Thomson and closed cycle linear and rotary coolers
- Preamplifiers
- Temperature controllers and readout electronics

Please contact us for more information on these products.



December, 2004