

High Power Pulsed Laser Diodes 1550-Series

FEATURES

- Single and stacked devices up to 50 Watts
- Proven InGaAsP high reliability structure
- 0.35 W/A efficiency
- Excellent temperature stability
- Hermetic and custom designed package
- 30 degree beam divergence



APPLICATIONS

- Eye safe range finding
- Surveying equipment
- "Friend or Foe" identification
- Laser radar
- Security barrier

GENERIC CHARACTERISTICS AT $t_{RT} = 21\text{ }^{\circ}\text{C}$

	Min	Typ	Max	Units
Wavelength of peak radiant intensity λ	1520	1550	1580	nm
Spectral bandwidth $\Delta\lambda$ at 50 % intensity points		20		nm
Wavelength temperature coefficient		0.50		nm/ $^{\circ}\text{C}$
Beam spread (50 % peak intensity)				
Parallel to junction plane \parallel		12		Degrees
Perpendicular to junction plane \perp				
Single element		30		Degrees
Stacks		30		Degrees



SINGLE CHIPS

Single chip characteristics at $t_{RT} = 21^{\circ}\text{C}$, $t_w = 150 \text{ ns}$, Duty Factor (DF) = 0.1 %

Parameter	155G1S02X	155G1S06X	155G1S14X
P_O at i_{fr} (min.)	3 W	5 W	12 W
Emitting area	50 x 1 μm	150 x 1 μm	350 x 1 μm
Peak forward current i_f	10 A	20 A	40 A
i_{FM} (max)*	20 A	40 A	80 A
Average power output (max)*	3 mW	6 mW	15 mW
I_{th} (typical)	0.4 A	0.8 A	1.9 A
V_F at i_f	2.8 V	3 V	4.1 V

STACKED ARRAYS

Stacked chip characteristics at $t_{RT} = 21^{\circ}\text{C}$, $t_w = 150 \text{ ns}$, Duty Factor (DF) = 0.1 %

Parameter	155G2S06X	155G4S14X
Number of elements	2	4
P_O at i_f , (min.)	10 W	45 W
Emitting area	150 x 150 μm	350 x 340 μm
Peak forward current i_f	20 A	40 A
i_{FM} (max)*	40 A	80 A
Average power output (max)*	6 mW	15 mW
I_{th} (typical)	0.8 A	1.9 A
V_F at i_f	3 V	4.1 V

*Notes on reliability and overdrive

These products have proven MTTF beyond 1000 hours when operated continuously at i_f and 0.1% duty cycle. Although the devices may be substantially overdriven it is important to respect maximum drive currents, i_{FM} and maximum average power output. Longevity under all overdrive conditions has not been verified, but should be acceptable for applications such as rangefinding where the on-time of the devices is limited. The devices must be adequately heat sunk, particularly in applications where the units are operated continuously. High temperature operation will reduce performance and MTTF.



ABSOLUTE MAXIMUM RATINGS

Maximum ratings	Limiting values
Peak reverse voltage	2 V
Pulse duration	
Single element	200 ns
Stacks	150 ns
Duty factor	0.1 %
Temperature	
Storage	- 55 °C to + 100 °C
Operating	- 45 °C to + 85 °C
Lead soldering 5 seconds max at	200 °C

Figure 1:
Wavelength vs. Temperature

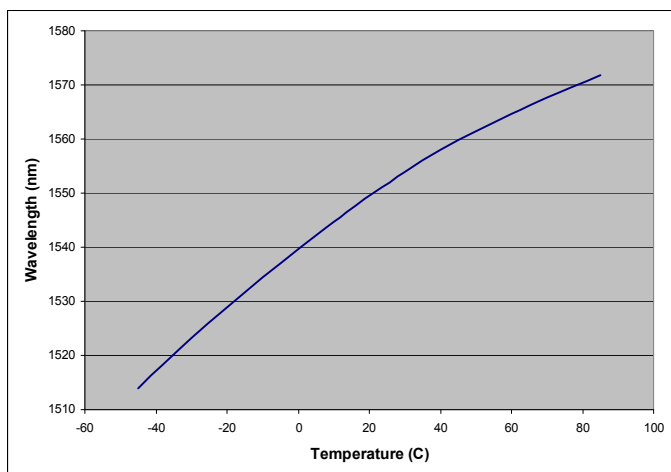

Figure 2:
Optical Output Power vs. Forward Current

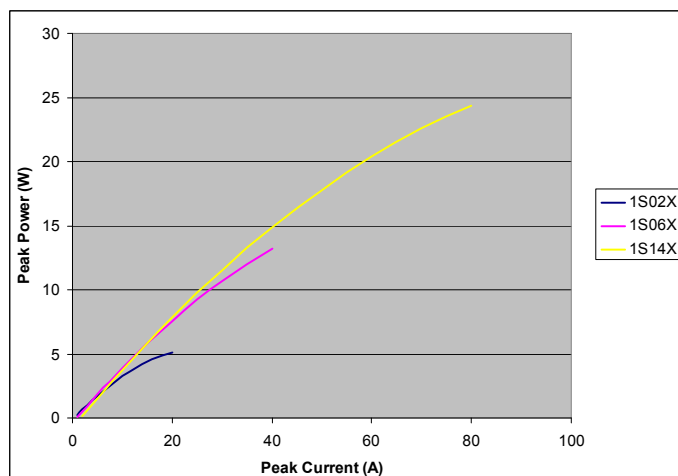

Figure 3:
Static Forward Voltage vs. Peak Current

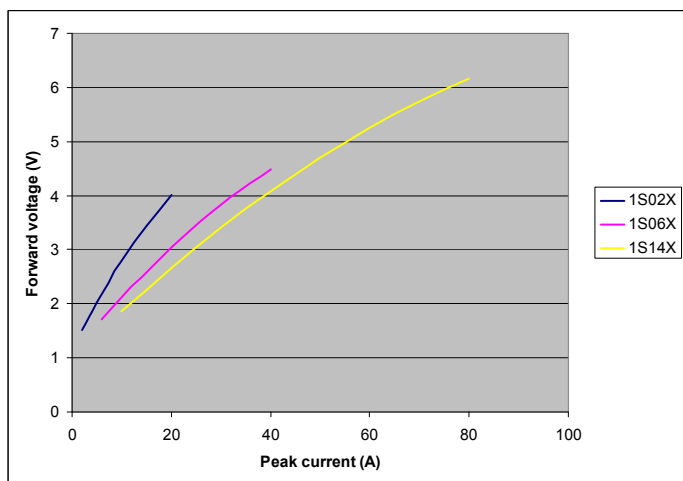

Figure 4:
Peak Optical Output Power vs. Temperature

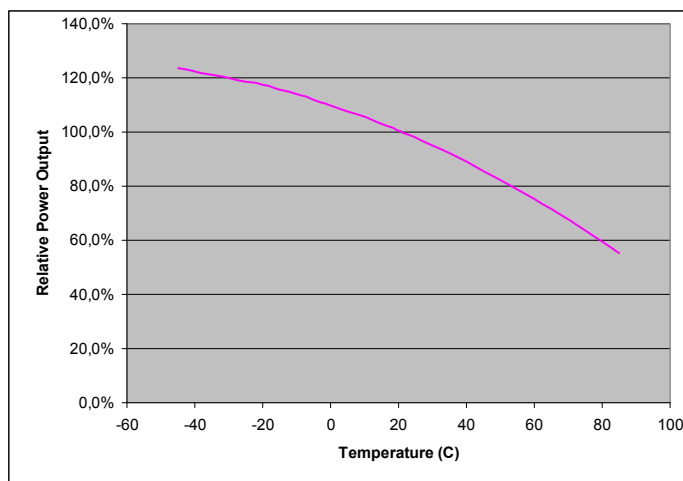

Figure 5:
Beam divergence parallel and perpendicular to the junction plane

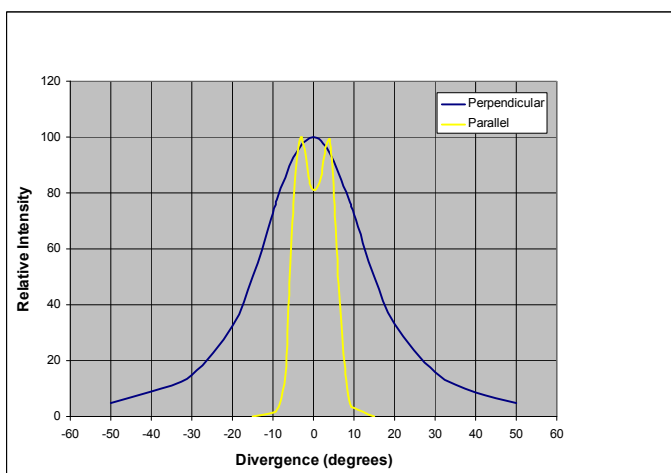
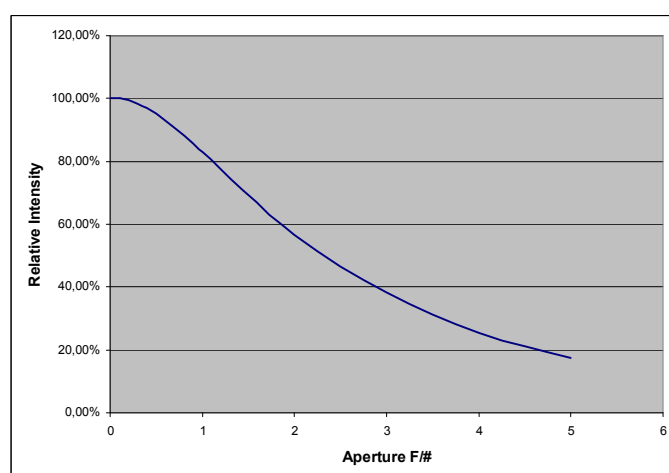
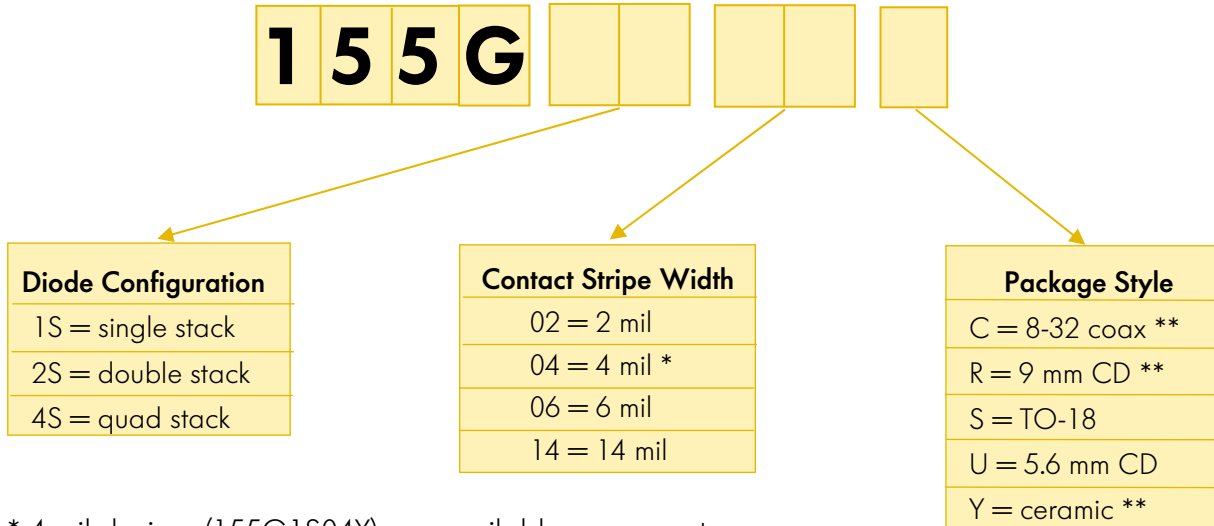

Figure 6:
Variation in Total Peak Power vs. Aperture Size



PRODUCT NUMBER DESIGNATION



* 4 mil devices (155G1S04X) are available on request.

** available on request.

PACKAGE DRAWINGS

Package U 5.6 mm CD

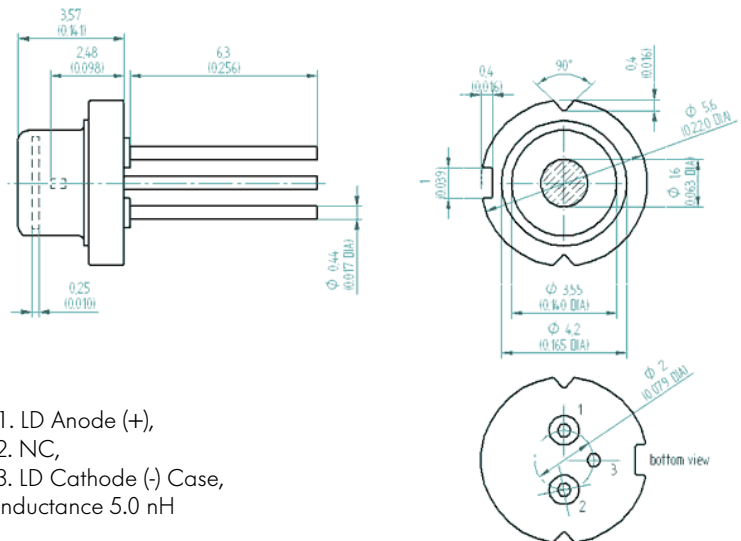
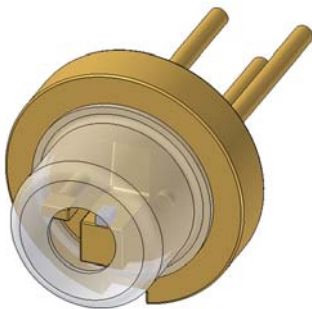

Package U: Pin Out: 1. LD Anode (+),
 2. NC,
 3. LD Cathode (-) Case,
 Inductance 5.0 nH



Package R 9 mm CD

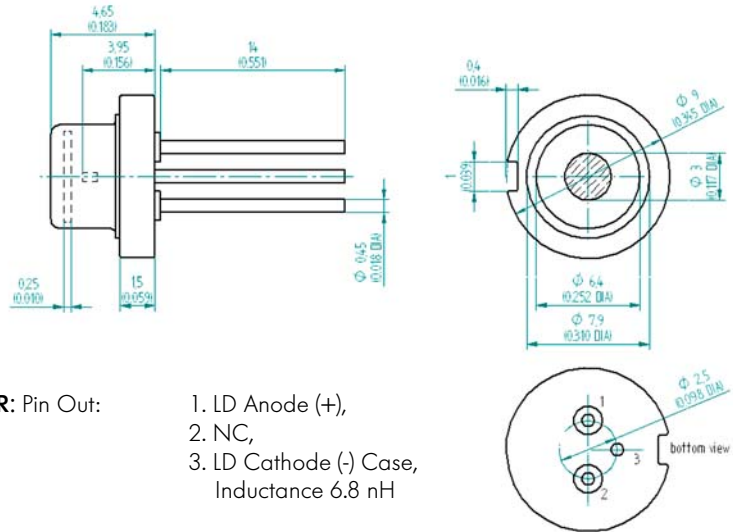

Package R: Pin Out:

1. LD Anode (+),
2. NC,
3. LD Cathode (-) Case, Inductance 6.8 nH

Package S TO-18

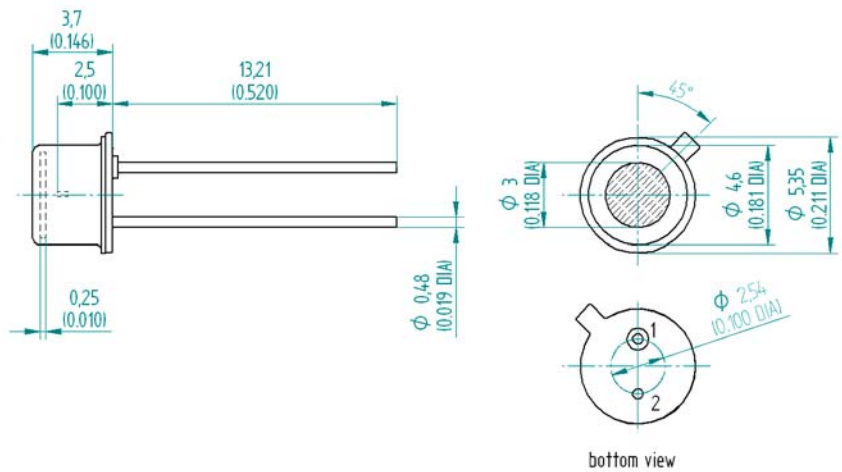
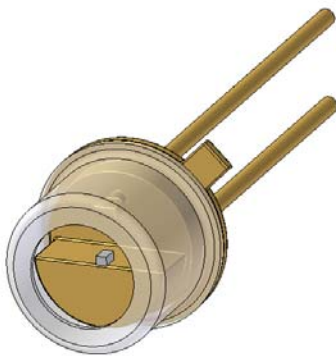

Package S: Pin Out: 1. LD Anode (+), 2. LD Cathode (-) Case, Inductance 5.2 nH



PRODUCT CHANGES

LASER COMPONENTS reserves the right to make changes to the product(s) or information contained herein without notice. No liability is assumed as a result of their use or application.

ORDERING INFORMATION

Products can be ordered directly from LASER COMPONENTS or its representatives. For a complete listing of representatives, visit our website at www.lasercomponents.com
Custom designed products are available on request.

LASER SAFETY

Personal Hazard:

Depending on the mode of operation, these devices emit highly concentrated non visible infrared light which can be hazardous to the human eye. Products which incorporate these devices have to follow the safety precautions given in IEC 60825-1 "Safety of laser products".

Handling Precautions:

Products are subject to the risks normally associated with sensitive electronic devices including static discharge, transients, and overload.



02/09 / V9 / IF / lcc / highpower_1550.doc

