

DC/DC High Voltage Modules dBC-Series

DESCRIPTION

The dBC series (dBC = digital bias controller) of miniature high voltage modules has been specially designed for avalanche photodiode (APD) operation. 3 versions are offered: The dBC-120-3x delivers a precisely controlled voltage in the range 1 – 120 V from a 3 V input voltage. This version is designed for use with InGaAs-APDs as well as very fast Si-PIN-photodiodes. The dBC-220-3x provides an output voltage range of 1 – 220 V, also from a 3 V supply, and is the ideal choice for most silicon APDs. Larger area APDs requiring higher voltages benefit from the dBC-380-5x which supplies up to 380 V from a 5 V input voltage. All three versions share a compact housing design with dimensions 21 mm x 21 mm x 8.3 mm.

The modules have integrated temperature compensation circuitry allowing both discrete APDs as well as APD modules with built-in temperature sensors to be controlled. An integrated current limiter ensures that the APD is protected against overexposure. The output voltage may be regulated using either an analog control voltage or voltage divider, or via the digital interface provided (SPI or RS-232). Suitable temperature sensors include silicon diodes or any sensor in the 2 – 10 kOhm range (at 25°C).

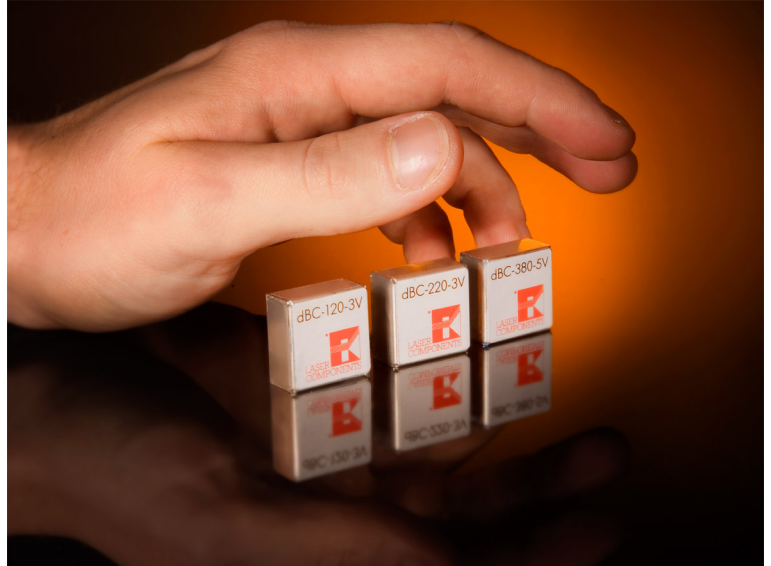

FEATURES

- Output voltage up to 380 V
- Temperature compensation
- High precision
- High stability
- Short-circuit proof
- Very low ripple
- Compact package
- Optional SPI or RS232 interface

APPLICATIONS

- Avalanche photodiodes
- PIN photodiodes
- Light sources
- Piezo elements



TECHNICAL SPECIFICATIONS

Part number	dBC-120-3x	dBC-220-3x	dBC-380-5x
Operating voltage	2.8 ... 12.5 V	2.8 ... 12.5 V	4.8 ... 12.5 V
Output voltage	1 ... 120 V	1 ... 220 V	1 ... 380 V
Output adjust	0 ... +2.2 VDC	0 ... +2.2 VDC	0 ... +2.2 VDC
TK adjust	0 ... +2.2 VDC	0 ... +2.2 VDC	0 ... +2.2 VDC
Temperature sensor * (default)	Si diode	Si diode	Si diode
Output current	max. 0.45 mA	max. 0.45 mA	0.3 mA @380 V max. 0.9 mA @ short-circuit
Operating temperature	-10°C ... + 50°C	-10°C ... + 50°C	-10°C ... + 50°C
Dimensions	21 x 21 x 8.3 mm	21 x 21 x 8.3 mm	21 x 21 x 8.3 mm
Weight	10 g	10 g	10 g

* other sensors may also be used

PIN CONFIGURATION

Pin	Function	Absolute max. rating
1	V _{in} / Operating voltage	[-0.3..15] V _{dc}
2	RS232: RxD * SPI: NSS	[-0.3..5.5] V
3	RS232: TxD * SPI: MOSI	[-0.3..5.5] V
4	SPI: MISO	[-0.3..5.5] V
5	SPI: SCLK	[-0.3..5.5] V
6	Constant current source for temp. sensor IREF	[-0.3..5.5] V max. 2 mA default = 1 mA
7	TK adjust A_TK	[-0.3..5.5] V
8	Output adjust A_ADJ	[-0.3..5.5] V
9	Temp. sensor	[-0.3..5.5] V
10	Reset and prog. interface C2CK / Reset	[-0.3..5.5] V
11	Prog. interface C2D	[-0.3..5.5] V
12	GND	GND
13/14	HV	Output max. 400 V
15/16	GND	GND

* Dual use pin: either RS232 or SPI interface
Pin 10/11: Programming interface (required for firmware updates)

SPI connection description:

- MOSI -> Master Out, Slave In
- MISO -> Master In, Slave Out
- SCLK -> Serial Clock
- NSS -> used in Multimaster Mode

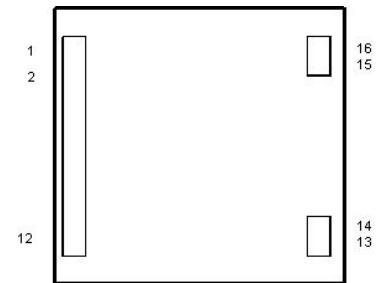

Topview

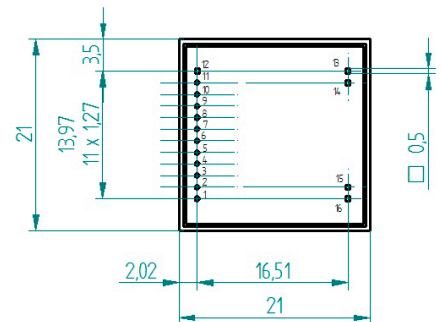

Bottomview

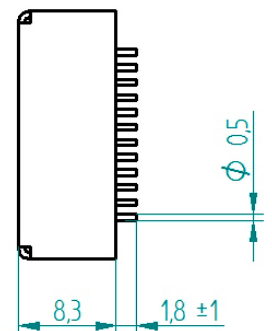

Sideview



OPERATIONAL MODES

Analog Mode

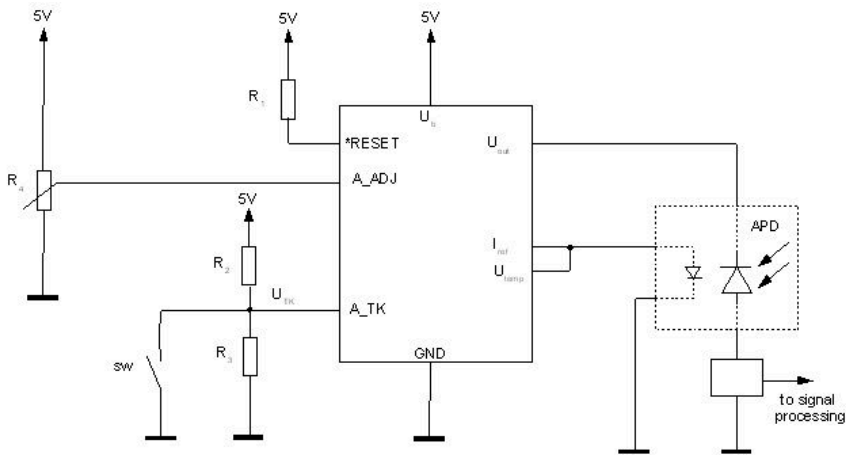

Function:

$$V_{out} = (V_{A_ADJ} * Gain) + (V_{TK} * d_{Temp})$$

$$d_{Temp} = Temp - 25^{\circ}C \text{ (Temperature difference)}$$

dBC-xxx	Gain
380-5x	215 ± 2
220-3x	114 ± 2
120-3x	60 ± 2

Setup:

„SW“ closed, or $V_{TK} = 0V$.

$$V_{out} = (V_{A_ADJ} * Gain) \quad \text{corresponds to } V_{out} \text{ at } 25^{\circ}C$$

Note: For operation without temperature compensation, A_TK must be connected to GND.

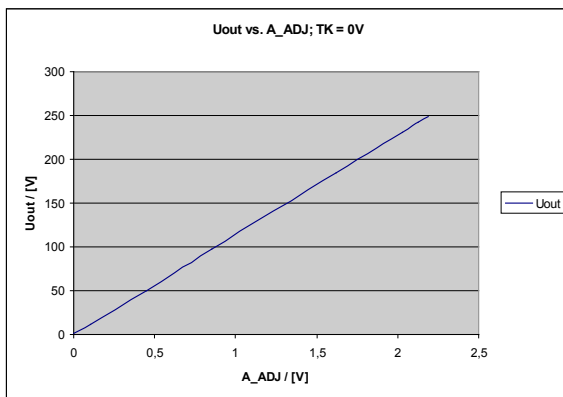

Example: dBC-220-3x



Temperature measurement (I_{ref}/V_{temp}):

I_{ref} : constant current source (default 1mA)
 V_{temp} : forward voltage Si diode or temperature sensor

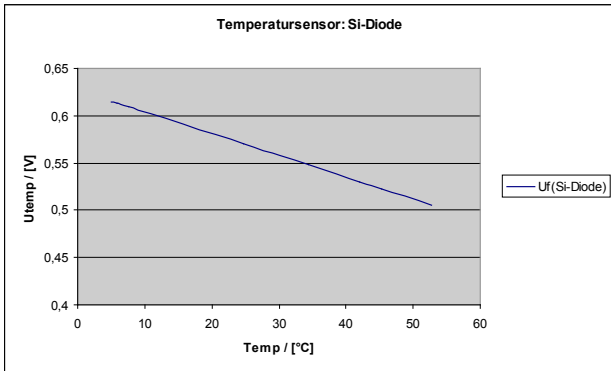

Other temperature sensors with the following parameters may also be used.
 $(I_{ref\ max.} = 2\ mA\ (V_{temp\ max.} = 2.2\ V);$ default 1mA; current source resolution: 12-Bit)

Remote control

Circuit example: RS232 interface:

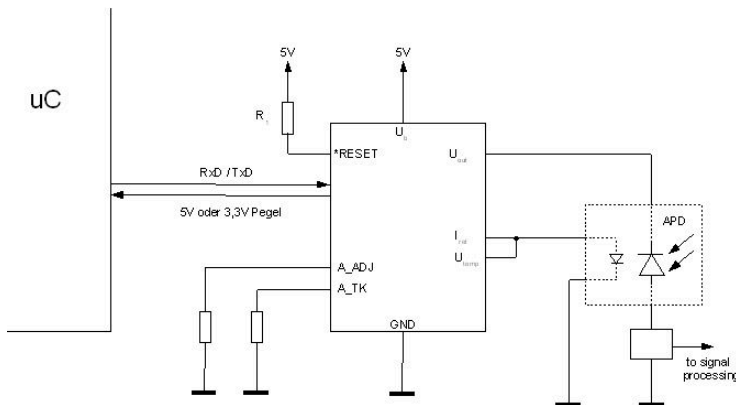

Serial interface setup: 8-Bit; 9600 Bd, no parity, no handshake

Circuit example: SPI-interface

3-wire single master and slave mode

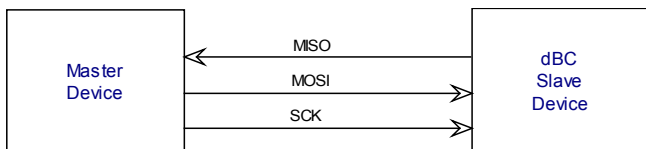

Optional: 4-wire single master and slave

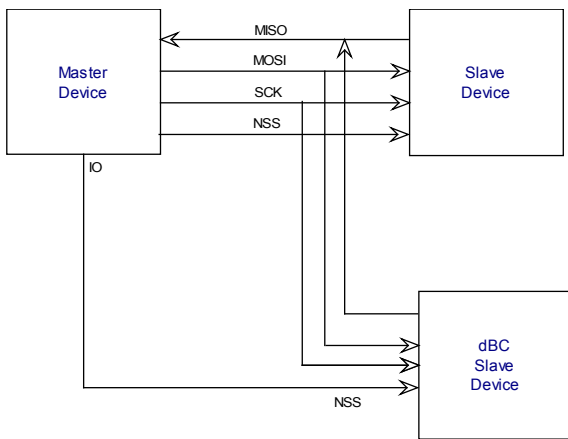

INTERFACE FUNCTIONS

Function	RS232 command	SPI command (2x 8 Bit see timing)	Response:	Description
V _{out} @25°C	U_xxxx	Hi-Byte = 1000 yyyy Low-Byte = yyyy yyyy	Hi-Byte = 1000 yyyy Low-Byte = yyyy yyyy	Output voltage at 25°C and TK = 0 mV (e.g. APD data sheet value)
TK value	T_xxxx	Hi-Byte = 0100 yyyy Low-Byte = yyyy yyyy	Hi-Byte = 0100 yyyy Low-Byte = yyyy yyyy	Temperature compensation value [mV] (V _{out} @25°C + Temp*TK)
TEMP ?	T_?	Hi-Byte = 0010 yyyy Low-Byte = yyyy yyyy	Hi-Byte = 0010 yyyy Low-Byte = yyyy yyyy	Temp. sensor readout (12-bit ADC value)
HV ?	V_?	Hi-Byte = 0001 yyyy Low-Byte = yyyy yyyy	Hi-Byte = 0001 yyyy Low-Byte = yyyy yyyy	HV readout (12-bit ADC value)
Module ON/OFF	M_1	Hi-Byte = 1001 yyyy Low-Byte = yyyy yyyy	Hi-Byte = 1001 0000 (0x90) Low-Byte = yyyy yyyy (0x90)	Output voltage on/off
	M_0	Hi-Byte = 1010 yyyy Low-Byte = yyyy yyyy	Hi-Byte = 1010 yyyy (0xA0) Low-Byte = yyyy yyyy (0xA0)	
Remote-Mode ON/OFF	R_1	Hi-Byte = 1011 yyyy Low-Byte = yyyy yyyy	Hi-Byte = 1011 0000 (0xA0) Low-Byte = 1011 0000 (0xC0)	Switching: Remote mode ↔ analog mode
	R_0	Hi-Byte = 1100 yyyy Low-Byte = yyyy yyyy	Hi-Byte = 1100 0000 (0xC0) Low-Byte = 1000 0000 (0xC0)	
SPI-Error			Hi-Byte = 1111 0000 (0xF0) Low-Byte = 1111 0000 (0xF0)	
Data out ON	D_1			Continuous readout TK [mV] HV [0,1 * V] Temperature [0,1 * °C]
OFF	„ESC“			
Help	H ?		Function table	

RS232 command: „_“ = space

SPI command: 4 bit function + 12 bit data (yyyy yyyy yyyy)

Application examples

1. Temperature compensation with Si diode as sensor:

APD data sheet values e.g. gain = 100; V_{opt} = 200 V; TK = 0.5 V/°C

Input following values:

V_{out} @25°C: 200 V

TK value: 0.5 V

The module automatically adjusts the high voltage in accordance with the measured temperature.



2. Temperature compensation with any sensor:

APD data sheet values e.g. gain = 100; $V_{opt} = 200\text{ V}$; $TK = 0.5\text{ V/}^\circ\text{C}$

TEMP \varnothing : Reads out the measured temperature and calculates the correct HV value
 $V_{out @25^\circ\text{C}}$: Corresponding to measured temperature
 TK value: 0 V

Default temperature measurement configuration:

$I_{ref} = 1\text{ mA}$; $V_{temp\ max} = 2.2\text{ V}$; $V_{temp\ resolution} = 12\text{-Bit}$

TIMING DIAGRAM: DBC IN SLAVE MODE

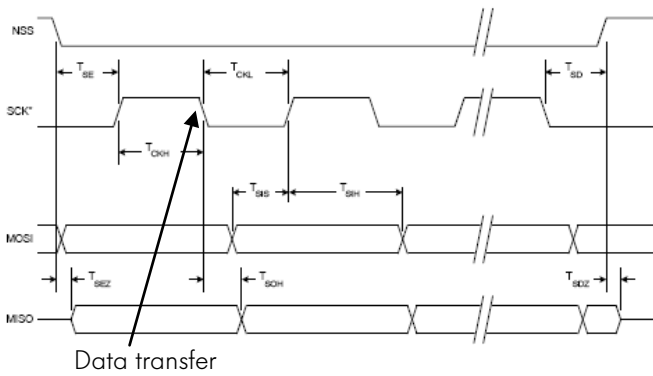

Write-read-delay	> 3.3 μs
T_{CKH} / T_{CKI}	> 80 ns
T_{SE} / T_{SD}	> 380 ns

SPI-TIMING: WRITE READ

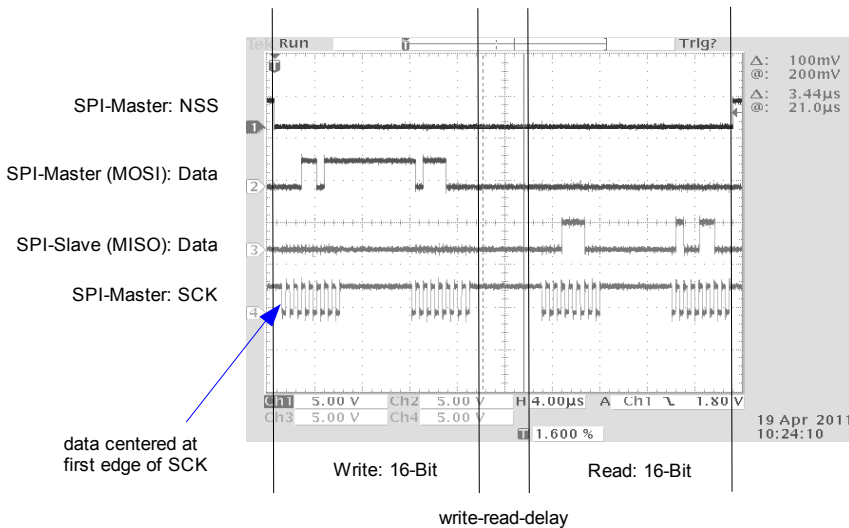

16 bits must be written and read out. The dBC module evaluates 4 data blocks. In the first two 8-bit blocks the data are read out, in the following blocks the dBC answers with 16-bit data. The 3.3 μs write-read-delay is required to allow the microprocessor to evaluate the write data.



DIAGRAMS

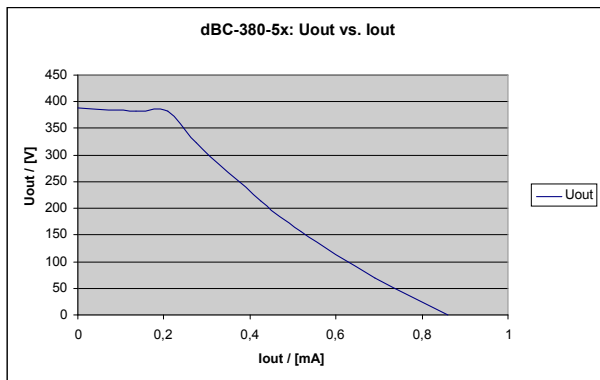

Current limiting curve for dBC-380-5x

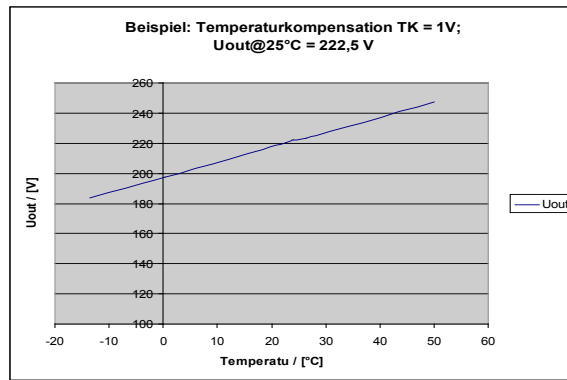

Example: temperature compensation

Noise and Ripple

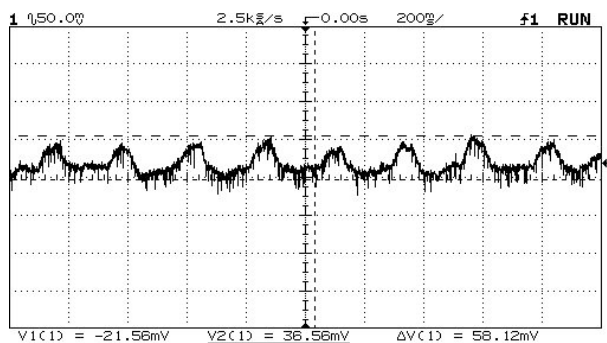

Measured ripple for dBC-380-5x at $V_{out} = 370\text{ Vdc}$
 Ripple: ca. $1.6 \cdot 10^{-4}$



ORDERING INFORMATION

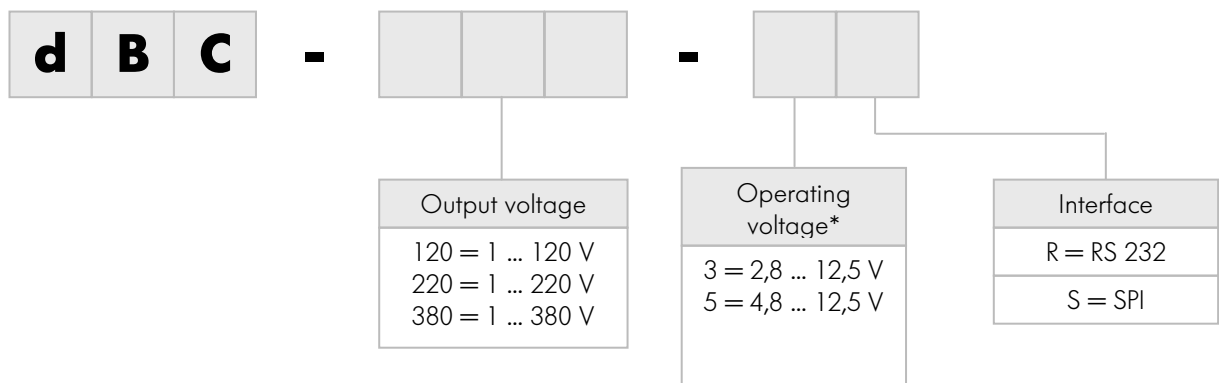

* 3 for dBC-120 und dBC-220
5 for dBC-380

DIMENSIONS

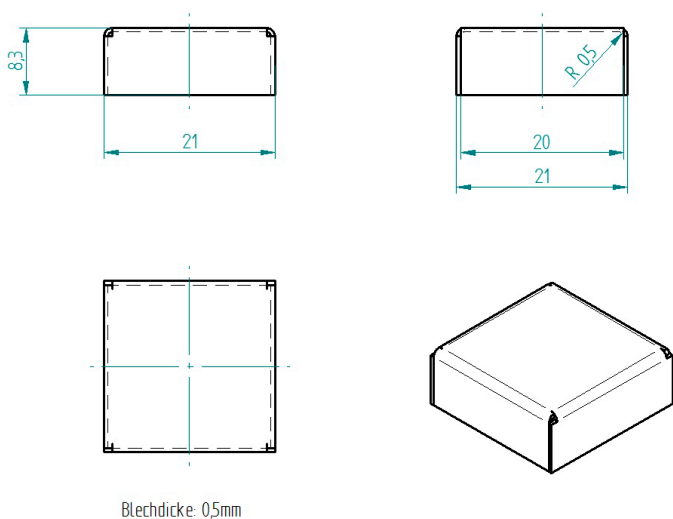

Dimensions ca. 21 x 21 x 10 mm

ACCESSORIES

A suitable Evaluation Board dBC-EVA-Board is available upon request.

07/11 / V4 / SB / lce/ dbc-series_e.doc