

# Diffraction Gratings

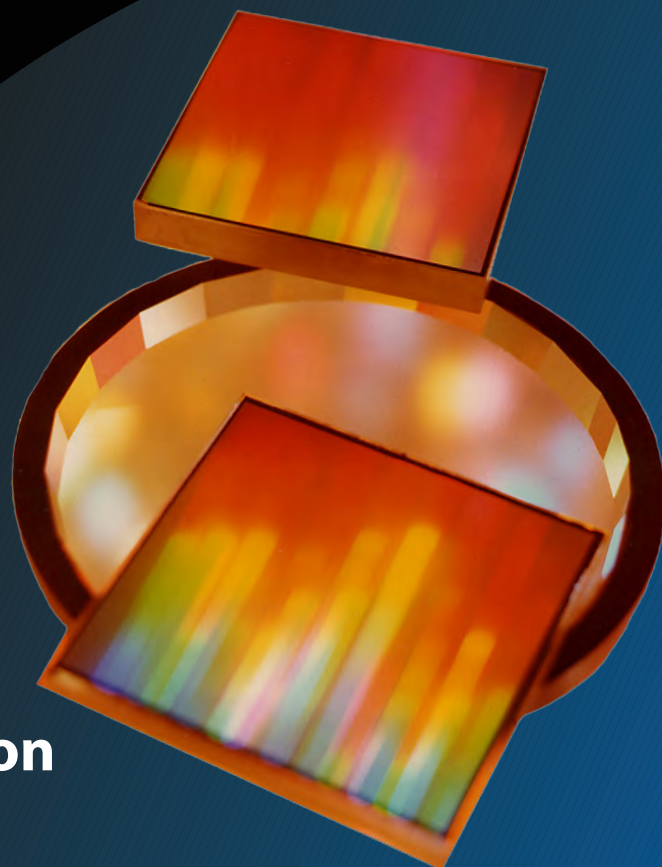

- Reflection Gratings
- Transmission Gratings
- Ruled and Holographic Gratings
- Beamsplitters
- UV-VIS-NIR

For Applications In:  
Chemistry  
Physics  
Life Science  
Engineering  
Communications



 **Optometrics Corporation**  
A Dynasil Company

LASER COMPONENTS (UK) Ltd  
Goldlay House, 114 Parkway, Chelmsford, Essex. CM2 7PR, Phone: 01245 491 499, Fax: 01245 491 801, [info@lasercomponents.co.uk](mailto:info@lasercomponents.co.uk)



Optometrics Corporation has, for more than twenty years, designed and manufactured a broad selection of diffraction gratings for a variety of applications in the industrial, educational and research markets. In-house ruling capabilities, along with both production and development holographic laboratories allow our customers to choose the right grating for their application. Standard gratings for spectroscopic instruments include both ruled and holographic replicas. Standard gratings for laser applications include high damage threshold original and replicated gratings for molecular lasers, holographic grazing incidence gratings for dye lasers, echelles. The newest additions to Optometrics' line of diffraction gratings include Transmission gratings, Telecom gratings and Reflecting/Transmitting "Polka-dot" beamsplitters.

## Facilities

Optometrics' facility in Ayer, Massachusetts contains space for offices, engineering, R&D and production. Equipment that support our broad range of capabilities includes:

- Four metal vacuum coating systems;
- Three thin-film soft coated filter vacuum coating systems;
- Two Ion-Assisted Deposition hard coat vacuum coating systems;
- Three grating ruling engines;
- Production holographic laboratory;
- R&D holographic laboratory;
- Full replication and lamination facilities;
- Full assembly, alignment and test facilities;
- Full complement of test equipment for spectral testing from the UV to the Far Infrared, for mechanical and flatness testing, for humidity and environmental testing;
- Extensive marking, packaging and bar coding equipment and capabilities

## Products

- **Gratings**  
Originals and Replicated, Ruled and Holographic; Grazing Incidence, Echelles, Telecom and Transmission Gratings

- **Beamsplitters**  
Reflecting/Transmitting Beamsplitters, Transmission Grating Beamsplitters, Beam Dividers/Combiners



- **Optical Components**  
Mirrors, Lenses, Windows, Flats, Beamsplitters, Prisms

- **Filters**  
Hard and Soft Coated, Near Ultraviolet, Visible, Near Infrared, Laser Line Filters

- **Infrared & Laser Products**  
Laser Gratings, Holographic and Ruled Wire Grid Polarizers



- **Monochromators**  
Mini-Chrom Monochromators



- **Systems & Accessories**  
Monochromatic Light Modules, Sample Compartments, Detectors, Light Sources, Modular Recording Spectrophotometers

- **SPF-290S**  
Spectrophotometer for determining Sunscreen Protection Factors

**Plus specialized packaging, bar coding and Kanban stocking arrangements for all OEM customers.**

## Goals

Optometrics goal is to provide advanced optical components and systems for use in wavelength selection applications found in:

- Analytical Chemistry
- Life Sciences
- Telecom Applications
- Physics
- Education
- Space Sciences

and other applications where high quality optics are key.

In order to accomplish this, the Company has assembled state-of-the-art facilities and people to produce:

- diffraction gratings, ruled & holographic, original & replicated, reflection and transmission
- interference and neutral density filters
- optical components
- laser gratings & products
- monochromators & accessories
- spectrophotometers
- wire grid polarizers, ruled & holographic, and

## OEM Services

Optometrics caters, in particular, to the needs of its OEM customers by offering special services such as:

- Kanban stocking arrangements
- Custom packaging programs
- Bar coding capabilities
- Code names for complete confidentiality
- Higher level pre-aligned optical assemblies

The company is also proud of its ability to support customers in all phases of the product development cycle.

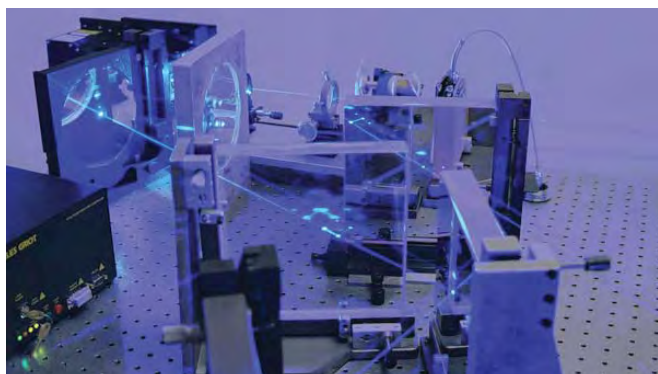

## TABLE OF CONTENTS

### Background Technology Information

Background & Technology Information.....4

### Products

#### Standard Ruled and Holographic

Replica Gratings.....10

High Resolution Gratings and Echelles.....14

#### TF and UTF Series Gratings and

Echelles For Dye Laser.....16

Grazing Incidence Gratings.....18

ML Series Replicated Gratings.....19

#### Transmission Gratings

Visible and NIR .....23

UV .....25

Reflecting Beam Dividers or Combiners.....26

Transmission Grating Beamsplitters.....27

#### Reflecting/Transmitting

“Polka Dot” Beamsplitters .....28

Spectroscopic Grating Kits .....30

## DIFFRACTION GRATINGS

A grating consists of a series of equally spaced parallel grooves formed in a reflective coating deposited on a suitable substrate. The distance between adjacent grooves and the angle the grooves form with respect to the substrate influence both the dispersion and efficiency of a grating. If the wavelength of the incident radiation is much larger than the groove spacing, diffraction will not occur. If the wavelength is much smaller than the groove spacing, the facets of the groove will act as mirrors and, again, no diffraction will take place.

The way in which the grooves are formed separates gratings into two basic types, holographic and ruled. Physically forming grooves into a reflective surface with a diamond mounted on a "ruling engine" produces ruled gratings. Gratings produced from laser constructed interference patterns and a photolithographic process are known as interference or holographic gratings.

Optometrics is one of the few companies that produces both types of gratings in-house and has full replication facilities and expertise. Ruled and holographic gratings differ in their optical characteristics and each type has advantages for specific applications.

## GRATING EQUATION

The general grating equation is usually written as:  
$$n\lambda = d(\sin i + \sin i')$$

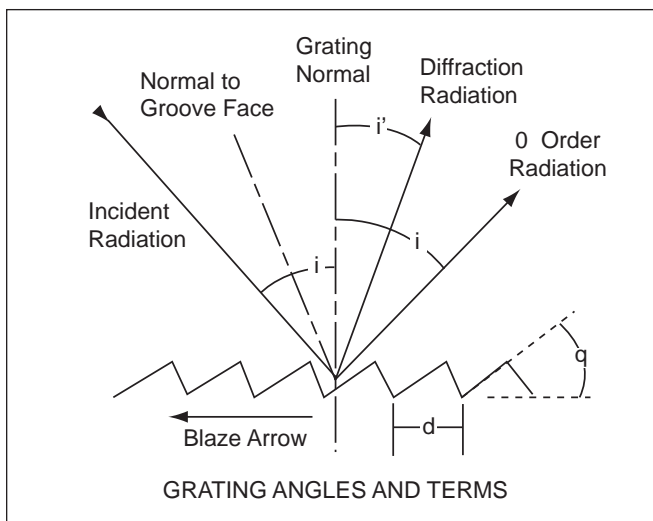

where  $n$  is the order of diffraction,  $\lambda$  is the diffracted wavelength,  $d$  is the grating constant (the distance between successive grooves),  $i$  is the angle of incidence measured from the normal and  $i'$  is the angle of diffraction measured from the normal.

For a specific diffracted order ( $n$ ) and angle of incidence ( $i$ ), different wavelengths ( $\lambda$ ) will have different diffraction angles ( $i'$ ), separating polychromatic radiation incident on the grating into its constituent wavelengths.

## THE RULING PROCESS

The initial steps in ruling an original or master grating includes the selection of an appropriate substrate, usually glass or copper, polishing the substrate to a high degree of flatness, and coating it with a thin layer of aluminum by vacuum deposition. The ruling of parallel, equally spaced grooves is a slow process that can require several days of set-up and testing prior to the actual ruling. The ruling engine must be able to retrace the exact path of the diamond forming tool on each stroke and to index (advance) the substrate a predetermined amount after each cut. Both groove parallelism and displacement must be controlled with great precision. A series of "test" rulings are made and the grating is checked for efficiency, groove profile and stray light. After each test, a minor mechanical adjustment may have to be made. It can take a week or more of repeated testing to optimize the groove profile for specific optical characteristics. After exhaustive testing, an original grating is ruled on a large substrate. An original grating is obviously very expensive and, consequently, gratings saw only limited use until after the development of the replication process.

## THE HOLOGRAPHIC PROCESS

Like a ruled grating, the first step in the production of a holographic grating is the selection of an appropriate polished substrate. The substrate for a holographic grating is, however, coated with a photosensitive (photoresist) material rather than the reflective coating used in ruled gratings. The photoresist is exposed by positioning the coated blank between the intersecting beams of monochromatic and coherent light produced by a laser. The intersecting laser beams generate a series of parallel,

equally spaced interference fringes whose intensities vary in a sinusoidal pattern. This fringe pattern exposes the resist differentially. Since the solubility of the resist is dependent on its exposure to light, the development process transfers the varying intensities of the interference fringes to the surface of the resist. The substrate is then coated with a reflective material and can be used as is, or replicated by the same process used for ruled originals.

Since holographic gratings are produced optically, groove form and spacing are perfectly consistent. Holographic gratings are, therefore, free from the periodic and random spacing errors responsible for “ghosts” and stray light in ruled gratings. The result is that holographic gratings generate much less stray light than ruled gratings.

### EFFICIENCY

Grating efficiency is primarily a function of groove shape, angle of incidence, and the reflectance of the coating.

The absolute efficiency of a grating is the percentage of incident monochromatic radiation that is diffracted into the desired order. In contrast, relative efficiency compares the energy diffracted into the desired order with that of a plane mirror coated with the same material as the grating. When comparing grating performance curves, it is important to keep this in mind. A relative efficiency curve will always show higher values than an absolute efficiency curve for the same grating. The efficiency curves in this brochure present absolute efficiency data.

Angle of incidence plays a role in grating performance. Because of the infinite number of configurations that a grating can be used in, a standard geometry is used in the measurement of the gratings. This is the Littrow (or autocollimation) mounting. In this mounting configuration, the diffracted order and wavelength of interest is directed back along the path of the incident light ( $i=i'$ ). The blaze angle of a ruled grating is calculated based on this mounting. This mounting is practical and necessary for laser

tuning applications, but most applications will require some deviation between the incident and diffracted beams. Small deviations from the Littrow mounting seldom have an appreciable effect on grating performance other than to limit the maximum wavelength achievable. Unless otherwise stated, all performance curves in this brochure present blazed first order Littrow data.

### BLAZE ANGLE AND WAVELENGTH

The grooves of a ruled grating have a sawtooth profile with one side longer than the other. The angle made by a groove's longer side and the plane of the grating is the “blaze angle”. Changing the blaze angle concentrates diffracted radiation to a specific region of the spectrum, increasing the efficiency of the grating in that region. The wavelength at which maximum efficiency occurs is the “blaze wavelength.”

Holographic gratings are generally less efficient than ruled gratings because they cannot be “blazed” in the classical sense. Their sinusoidal shape can, in some instances, be altered to approach the efficiency of a ruled grating. There are also special cases that should be noted, i.e. when the spacing to wavelength ratio is near one, a sinusoidal grating has virtually the same efficiency as a ruled grating. A holographic grating with 1800 g/mm can have the same efficiency at 500 nm as a blazed, ruled grating. In addition, a special process enables Optometrics' holographic gratings to achieve a true sawtooth profile peaked at 250 nm, an ideal configuration for UV applications requiring good efficiency with low stray light.

## RESOLVING POWER

The resolving power of a grating is the product of the diffracted order in which it is used and the number of grooves intercepted by the incident radiation. It can also be expressed in terms of grating width, groove spacing and diffracted angles. The “theoretical resolving power” of a diffraction grating with N grooves is:

$$\frac{\lambda}{\Delta\lambda} = Nn$$

The actual resolving power of a grating depends on the accuracy of the ruling, with 80-90% of theoretical being typical of a high quality ruling.

Resolving power is a property of the grating and is not, like resolution, dependent on the optical and mechanical characteristics of the system in which it is used.

## SYSTEM RESOLUTION

The resolution of an optical system, usually determined by examination of closely spaced absorption or emission lines for adherence to the Raleigh criteria ( $R = \lambda/\Delta\lambda$ ), depends not only on the grating resolving power but on focal length, slit size, f number, the optical quality of all components and system alignment. The resolution of an optical system is usually much less than the resolving power of the grating.

## DISPERSION

Angular dispersion of a grating is a product of the angle of incidence and groove spacing. Angular dispersion can be increased by increasing the angle of incidence or by decreasing the distance between successive grooves. A grating with a large angular dispersion can produce good resolution in a compact optical system.

Angular dispersion is the slope of the curve given by  $\lambda = f(i)$ . In autocollimation, the equation for dispersion is given by:

$$\frac{d\lambda}{di} = \frac{\lambda}{2 \tan i}$$

This formula may be used to determine the angular separation of two spectral lines or the bandwidth that will be passed by a slit subtending a given angle at the grating.

## DIFFRACTED ORDERS

For a given set of angles ( $i, i'$ ) and groove spacing, the grating equation is valid at more than one wavelength, giving rise to several “orders” of diffracted radiation. The reinforcement (constructive interference) of diffracted radiation from adjacent grooves occurs when a ray is in phase but retarded by a whole integer. The number of orders produced is limited by the groove spacing and the angle of incidence, which obviously cannot exceed 90 degrees. At higher orders, efficiency and free spectral range decrease while angular dispersion increases. Order overlap can be compensated for by the judicious use of sources, detectors and filters and is not a major problem in gratings used in low orders.

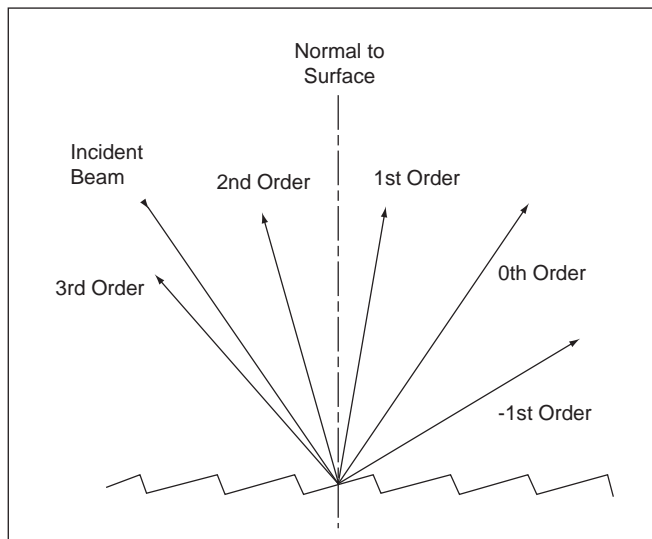

## FREE SPECTRAL RANGE

Free spectral range is the maximum spectral bandwidth that can be obtained in a specified order without spectral interference (overlap) from adjacent orders. As grating spacing decreases, the free spectral range increases. It decreases with higher orders. If  $\lambda_1$ ,  $\lambda_2$  are lower and upper limits, respectively, of the band of interest, then:

$$\text{Free spectral range} = \lambda_2 - \lambda_1 = \lambda_1/n$$

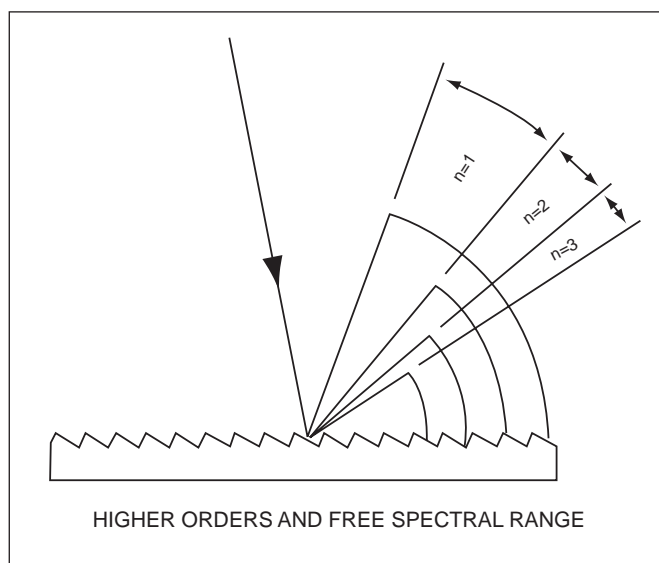

## GHOSTS AND STRAY LIGHT

Ghosts are defined as spurious spectral lines arising from periodic errors in groove spacing. Interferometrically controlled ruling engines minimize ghosts, while the holographic process eliminates them.

On ruled gratings, stray light originates from random errors and irregularities of the reflecting surfaces. Holographic gratings generate less stray light because the optical process which transfers the interference pattern to the photoresist is not subject to mechanical irregularities or inconsistencies.

## SIZES

Gratings are available in several standard square and rectangular sizes ranging from 12.5 mm square up to 50mm square. Non-standard sizes are available upon request. Unless otherwise specified, rectangular gratings are cut with grooves parallel to the short dimension.

## SUBSTRATES

Replicated gratings of all types can be produced on float glass, Pyrex® or Zerodur®. Optometrics carries all three types of substrates in stock, in 3mm, 4mm, 5mm, 6mm, 9.5mm, and 12mm thicknesses. Other materials and thicknesses are available upon request.

## COATINGS

Gratings used in the ultraviolet, visible and infrared are normally replicated with an aluminum coating. Aluminum is used rather than silver because it is more resistant to oxidation and has superior reflectance in the ultraviolet. Aluminum averages over 90% reflectance from 200 nm to the far infrared, except in the 750 to 900 nm region where it drops to approximately 85%. When maximum reflectance is required in the near infrared, as is the case with some fiber optic applications, the aluminum coating may be overcoated with gold. Though gold is soft, it

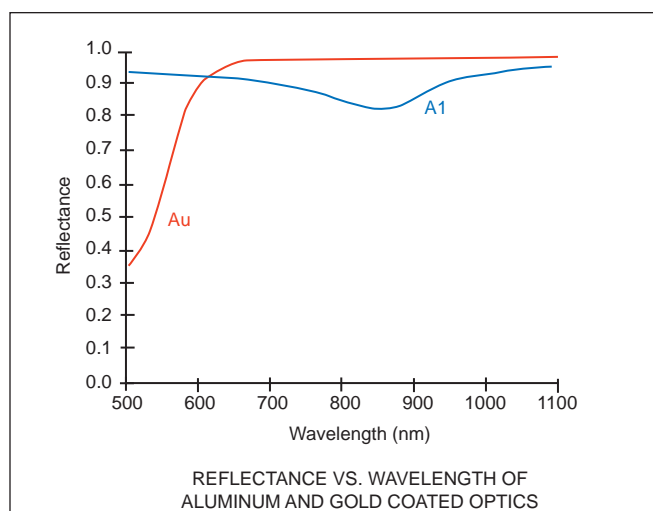

is resistant to oxidation and has a reflectance of over 96% in the near infrared and over 98% above 2.0  $\mu$ . The reflectance of gold drops substantially below 600 nm and is not recommended for use in the visible or ultraviolet regions.

Dielectric overcoatings such as aluminum magnesium fluoride ( $\text{AlMgF}_2$ ) protect aluminum from oxidation, maintaining the original high reflectance of aluminum in the visible and ultraviolet. Gold overcoatings and aluminum magnesium fluoride dielectric coatings must be specified separately when ordering.

While gold overcoating can increase reflectivity, any overcoating may reduce the damage threshold by a factor of two or more.

## DAMAGE THRESHOLDS

Any standard Optometrics grating is available with either P-type or CW-type replication coatings for higher damage threshold performance. (For more information see page 9).

## CHOOSING A GRATING

Selection of a standard Optometrics grating requires consideration of a number of variables related to the grating's intended use. These are as follows:

- **EFFICIENCY:** In general, ruled gratings have a higher efficiency than holographic gratings. Applications such as fluorescence excitation and other radiation induced reactions may require a ruled grating (see efficiency curves for comparison). As a rule of thumb, the first order efficiency of a ruled grating decreases by 50% at two thirds and three halves of the blaze wavelength.
- **BLAZE WAVELENGTH:** Ruled gratings, due to their "sawtooth" groove profile, have a relatively sharp peak around their blaze wavelength while some holographic gratings have a flatter spectral response. Applications centered around a narrow wavelength range could benefit from a ruled grating blazed at that wavelength.
- **WAVELENGTH RANGE:** The spectral range covered by a grating is dependent on groove spacing and is the same for ruled and holographic gratings with the same grating constant. The maximum

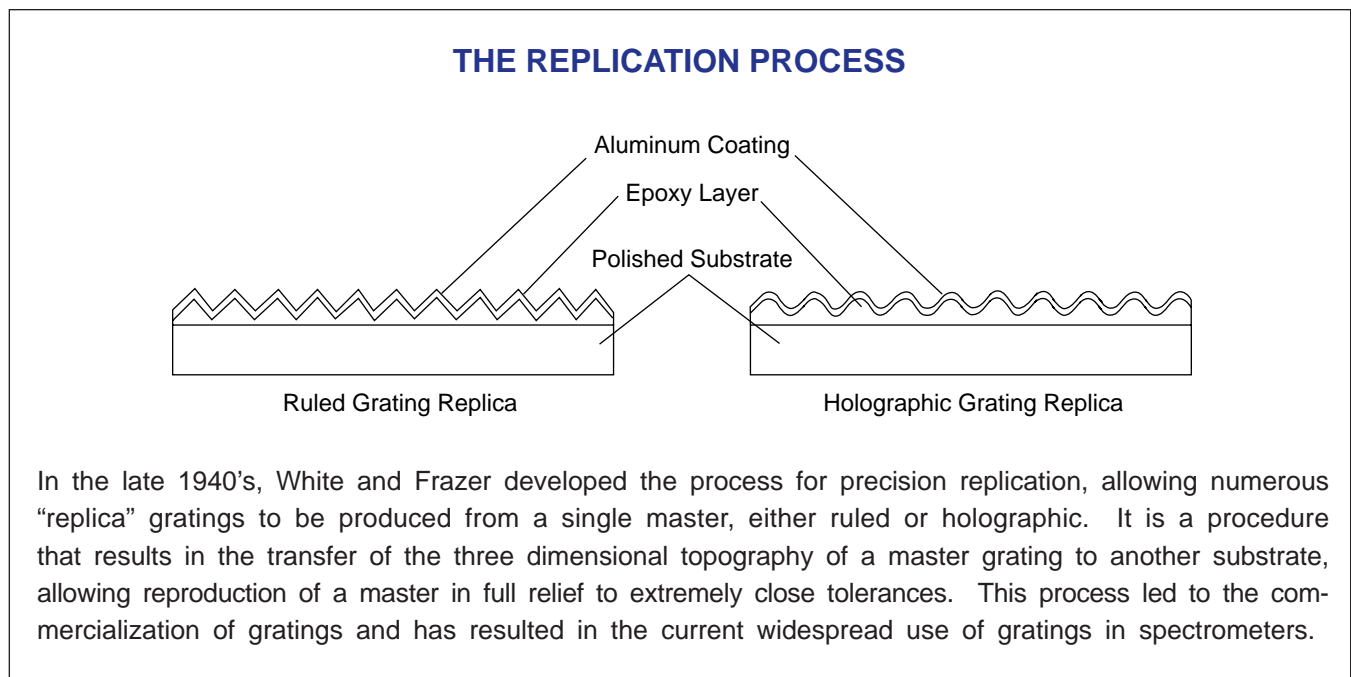

wavelength that a grating can diffract is equal to two times the grating period, and this would be achieved when the incident and diffracted light were at ninety degrees to the grating normal.

- **STRAY LIGHT:** For applications such as Raman spectroscopy, where signal-to-noise is critical, the inherent low stray light of a holographic grating is an advantage.
- **RESOLVING POWER:** There is no difference in resolving power for holographic and ruled gratings with identical groove spacing. Holographic gratings are, however, available with up to 3600 grooves per mm while Optometrics does not normally rule gratings with more than 1200 grooves per mm.

## TYPICAL SPECIFICATIONS

Dimensional tolerances .....	$\pm 0.5$ mm
Thickness tolerances .....	$\pm 0.5$ mm
Efficiencies:	
Ruled .....	60 - 80% at blaze $\lambda$
Holographic .....	45 - 65% at peak $\lambda$
Clear aperture .....	90%
Groove parallelism to edge .....	$\pm 0.5^\circ$

## HANDLING GRATINGS

The surface of standard gratings are coated with aluminum or gold and require extreme care when handling. Handling should be done by the edges only. These relatively soft coatings are vulnerable to fingerprints and numerous aerosols. Scratches or other cosmetic defects do not, unless extreme, usually affect optical performance. No attempt to clean a grating should be made without first consulting Optometrics.

## RECTANGLES / GROOVE DIRECTION

Unless otherwise specified, rectangular gratings are cut with grooves parallel to the short dimension.

## DAMAGE THRESHOLD

Any standard Optometrics grating is available with either P-type or CW-type construction or higher damage threshold performance.

**Damage Thresholds:** (no damage threshold minimums apply to gratings with an overcoat)

### Standard Replica Gratings:

Pulsed .....	350 milli-joules/cm <sup>2</sup> @ 200 n sec.
CW .....	40 watts/cm <sup>2</sup>

### P-Type Replica Gratings: (pulsed type)

Pulsed .....	3.5 joules/cm <sup>2</sup> @ 200 n sec.
CW .....	80 watts/cm <sup>2</sup>

### CW-Type Replica Gratings: (for continuous high power applications)

Pulsed .....	3.5 joules/cm <sup>2</sup> @ 200 n sec.
CW .....	250 watts/cm <sup>2</sup>

## Coatings

Gold Overcoat (AU3)  
Aluminum Magnesium Flouride (ALMG-3)

**Note:** while a gold overcoat can increase reflectivity, any overcoating may reduce the damage threshold by a factor of two or more.

# Diffraction Gratings | Ruled and Holographic Gratings

Standard replicated gratings are produced from ruled and holographic originals and are intended for use in moderate resolution spectrophotometers, spectrometers and monochromators where low cost, high efficiency and low stray light are of primary concern. Since standard gratings are cut from larger replicas, they are ruled over their entire surface. Incident radiation should, however, be restricted to 90% of the ruled area.

## Standard Series Replicated Ruled Gratings

GROOVES /MM	BLAZE $\lambda$ (nm)	BLAZE ANGLE	DISPERSION (nm/mr)	12.7 x 12.7 x 6	25 x 25 x 6	25 x 25 x 9.5	30 x 30 x 9.5	50 x 50 x 9.5	12.5 x 25 x 6	12.5 x 25 x 9.5	25 x 50 x 9.5
120	12000	46° 3'	5.78	3-4112	3-8112	3-2112	3-3112	3-5112	3-6112	3-1112	3-7112
150	500	2° 8'	6.66	3-4155	3-8155	3-2155	3-3155	3-5155	3-6155	3-1155	3-7155
300	300	2° 34'	3.33	3-4330	3-8330	3-2330	3-3330	3-5330	3-6330	3-1330	3-7330
300	500	4° 18'	3.32	3-4350	3-8350	3-2350	3-3350	3-5350	3-6350	3-1350	3-7350
300	1000	8° 36'	3.30	3-4310	3-8310	3-2310	3-3310	3-5310	3-6310	3-1310	3-7310
300	2000	17° 27'	3.18	3-4320	3-8320	3-2320	3-3320	3-5320	3-6320	3-1320	3-7320
300	4000	36° 52'	2.67	3-4340	3-8340	3-2340	3-3340	3-5340	3-6340	3-1340	3-7340
600	300	5° 9'	1.66	3-4630	3-8630	3-2630	3-3630	3-5630	3-6630	3-1630	3-7630
600	400	6° 53'	1.66	3-4640	3-8640	3-2640	3-3640	3-5640	3-6640	3-1640	3-7640
600	500	8° 37'	1.65	3-4650	3-8650	3-2650	3-3650	3-5650	3-6650	3-1650	3-7650
600	750	13° 0'	1.62	3-4675	3-8675	3-2675	3-3675	3-5675	3-6675	3-1675	3-7675
600	1000	17° 27'	1.59	3-4610	3-8610	3-2610	3-3610	3-5610	3-6610	3-1610	3-7610
600	1250	22° 1'	1.55	3-4612	3-8612	3-2612	3-3612	3-5612	3-6612	3-1612	3-7612
600	1600	28° 41'	1.46	3-4616	3-8616	3-2616	3-3616	3-5616	3-6616	3-1616	3-7616
830	800	19° 23'	1.14	3-4880	3-8880	3-2880	3-3880	3-5880	3-6880	3-1880	3-7880
830	1200	29° 52'	1.05	3-4812	3-8812	3-2812	3-3812	3-5812	3-6812	3-1812	3-7812
900	500	13° 0'	1.08	3-4712	3-8712	3-2712	3-3712	3-5712	3-6712	3-1712	3-7712
1200	250	8° 37'	0.82	3-4125	3-8125	3-2125	3-3125	3-5125	3-6125	3-1125	3-7125
1200	300	10° 22'	0.82	3-4130	3-8130	3-2130	3-3130	3-5130	3-6130	3-1130	3-7130
1200	400	13° 53'	0.81	3-4140	3-8140	3-2140	3-3140	3-5140	3-6140	3-1140	3-7140
1200	500	17° 27'	0.80	3-4150	3-8150	3-2150	3-3150	3-5150	3-6150	3-1150	3-7150
1200	750	26° 44'	0.74	3-4175	3-8175	3-2175	3-3175	3-5175	3-6175	3-1175	3-7175
1200	1000	36° 52'	0.67	3-4110	3-8110	3-2110	3-3110	3-5110	3-6110	3-1110	3-7110
1800	240	12° 29'	0.54	3-4162	3-8162	3-2162	3-3162	3-5162	3-6162	3-1162	3-7162
1800	500	26° 44'	0.50	3-4185	3-8185	3-2185	3-3185	3-5185	3-6185	3-1185	3-7185

(All dimensions in millimeters) See page 12 for typical efficiency curves.

## Standard Series Replicated Holographic Gratings

GROOVES /MM	OPTIMUM EFFICIENCY	DISPERSION (nm/mr)	12.7 x 12.7 x 6	25 x 25 x 6	25 x 25 x 9.5	30 x 30 x 9.5	50 x 50 x 9.5	12.5 x 25 x 6	12.5 x 25 x 9.5	25 x 50 x 9.5
600	UV	1.67 @ 250 NM	3-4021	3-8021	3-2021	3-3021	3-5021	3-6021	3-1021	3-7021
1000	UV	0.99 @ 250 NM	3-4061	3-8061	3-2061	3-3061	3-5061	3-6061	3-1061	3-7061
1200	UV	0.82 @ 250 NM	3-4121	3-8121	3-2121	3-3121	3-5121	3-6121	3-1121	3-7121
1200	VIS	0.79 @ 500 NM	3-4122	3-8122	3-2122	3-3122	3-5122	3-6122	3-1122	3-7122
1800	UV	0.54 @ 250NM	3-4181	3-8181	3-2181	3-3181	3-5181	3-6181	3-1181	3-7181
1800	VIS	0.50 @ 500 NM	3-4182	3-8182	3-2182	3-3182	3-5182	3-6182	3-1182	3-7182
2400	UV	0.40 @ 250 NM	3-4241	3-8241	3-2241	3-3241	3-5241	3-6241	3-1241	3-7241
2400	VIS	0.33 @ 500 NM	3-4242	3-8242	3-2242	3-3242	3-5242	3-6242	3-1242	3-7252
3600	UV	0.25 @ 250 NM	3-4361	3-8361	3-2361	3-3361	3-5361	3-6361	3-1361	3-7361

(All dimensions in millimeters) See page 13 for typical efficiency curves.

### COATINGS

Protective overcoatings that maintain or enhance reflectivity in the UV, Visible and IR regions are available for an additional charge.

Gold Overcoat (AU-3) .....

Aluminum Magnesium Fluoride (ALMG-3) .....

# Diffraction Gratings | Typical Efficiency Curves - Ruled Gratings

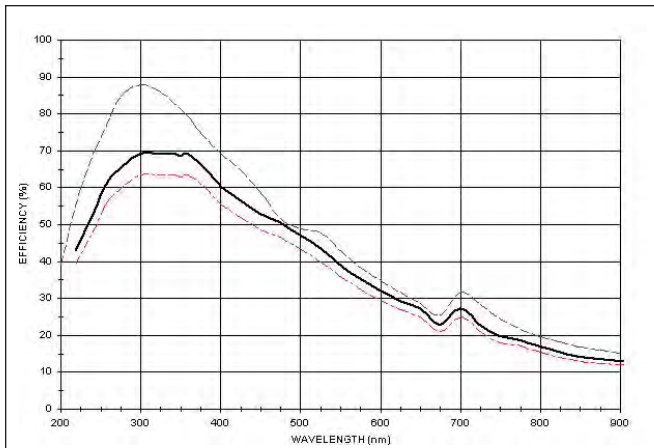

600 grooves/mm BLAZED at 300 nm

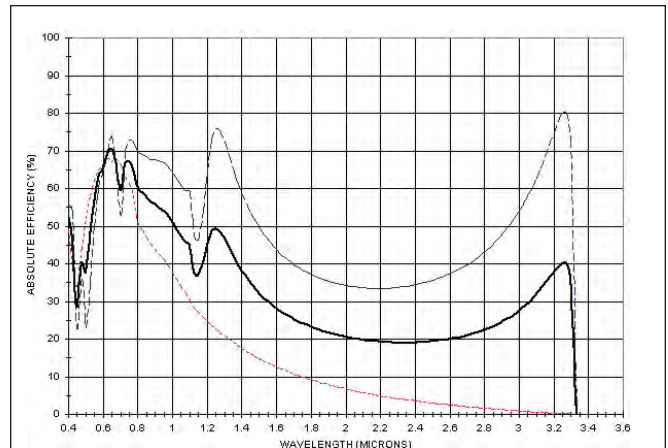

600 grooves/mm BLAZED at 750 nm

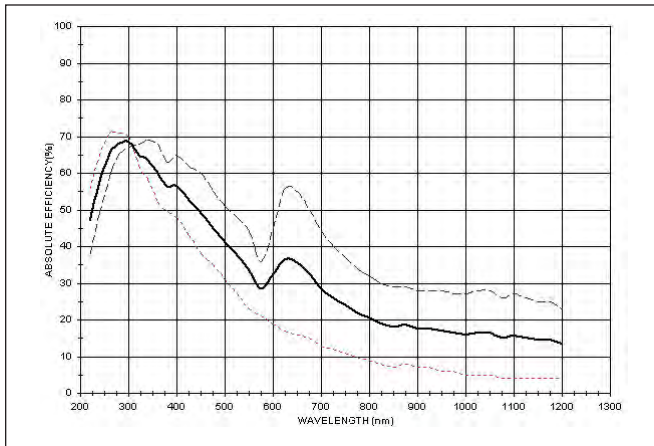

1200 grooves/mm BLAZED at 250 nm

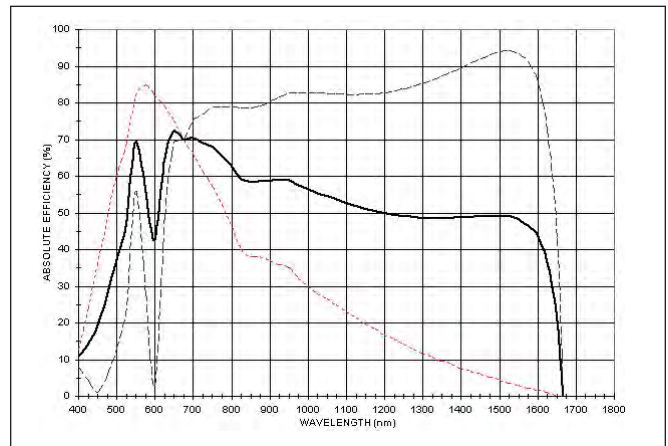

1200 grooves/mm BLAZED at 750 nm

These are several of Optometrics grating efficiency curves. Efficiency curves for all Optometrics gratings are available on our website, [www.optometrics.com](http://www.optometrics.com)

- — — — — Perpendicular Polarization
- ..... Parallel Polarization
- Average

### Efficiency Curve Key

- All gratings are measured in the Littrow mounting in 1st order
- All gratings utilize an aluminum (Al) reflective coat

# Typical Efficiency Curves - Holographic Gratings | Diffraction Gratings

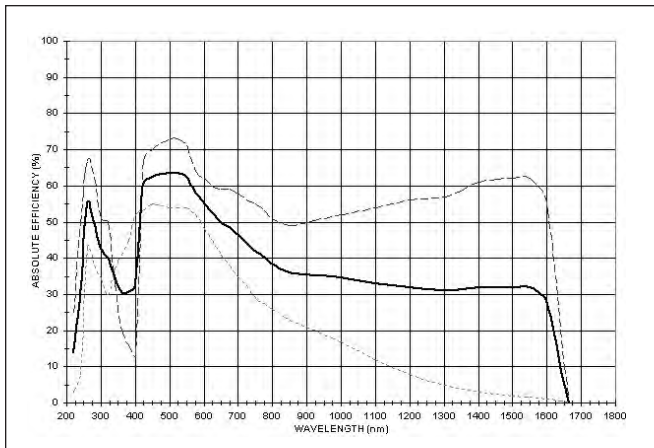

1200 grooves/mm OPTIMIZED FOR THE VISIBLE

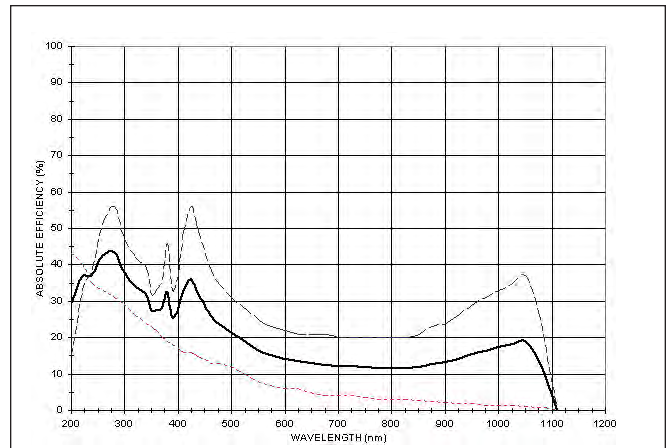

1800 grooves/mm OPTIMIZED FOR THE UV

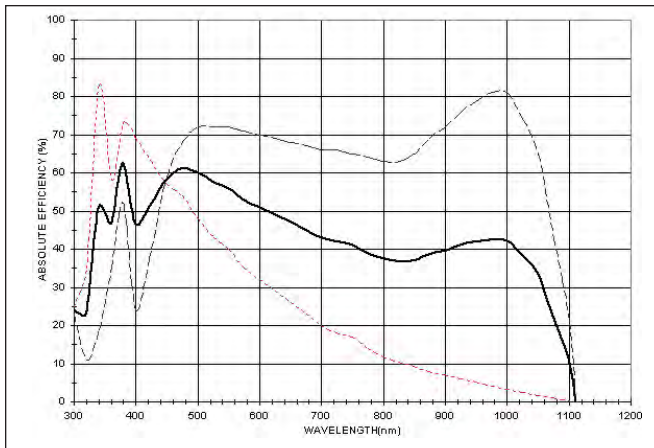

1800 grooves/mm OPTIMIZED FOR THE VISIBLE

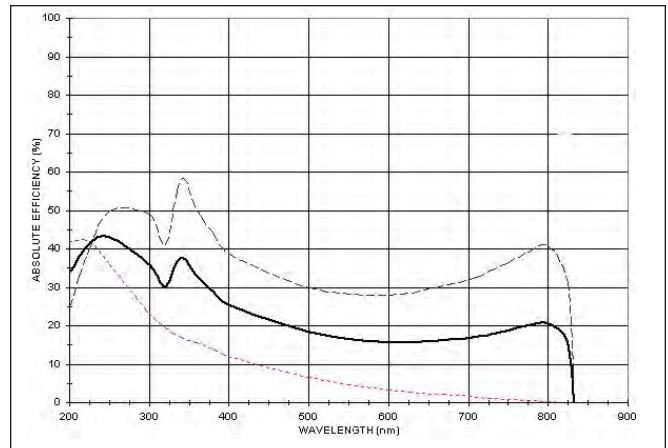

2400 grooves/mm OPTIMIZED FOR THE UV

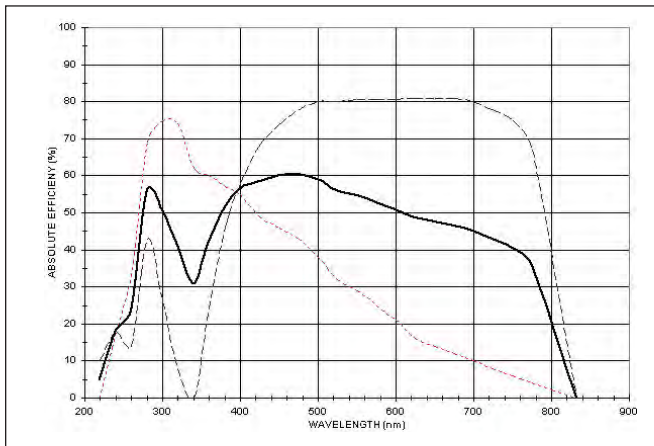

2400 grooves/mm OPTIMIZED FOR THE VISIBLE

These are several of Optometrics grating efficiency curves. Efficiency curves for all Optometrics gratings are available on our website, [www.optometrics.com](http://www.optometrics.com)

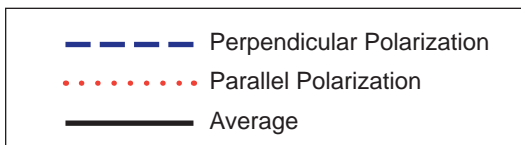

### Efficiency Curve Key

- All gratings are measured in the Littrow mounting in 1st order
- All gratings utilize an aluminum (Al) reflective coat

## High Resolution Ruled Gratings

Replicating master gratings on Pyrex®, produces gratings with flatness,  $\lambda/4$  or better, good thermal stability and resolution equal to 80-90% of the master. High resolution gratings are available in groove spacings from 120 to 1800 g/mm, blazed from 240 nm to 12.0 $\mu$ . For even better thermal stability, ask for a quotation for gratings replicated on Zerodur®.

GROOVES /MM	BLAZE $\lambda$ (nm)	BLAZE ANGLE	DISPERSION (nm/mr)	12.7 x 12.7 x 6	25 x 25 x 6	25 x 25 x 9.5	30 x 30 x 9.5	50 x 50 x 9.5	12.5 x 25 x 6	12.5 x 25 x 9.5	25 x 50 x 9.5
120	12000	46° 3'	5.78	3-4219	3-8219	3-2219	3-3219	3-5219	3-6219	3-1219	3-7219
150	500	2° 8'	6.66	3-4559	3-8559	3-2559	3-3559	3-5559	3-6559	3-1559	3-7559
300	300	2° 34'	3.33	3-4339	3-8339	3-2339	3-3339	3-5339	3-6339	3-1339	3-7339
300	500	4° 18'	3.32	3-4359	3-8359	3-2359	3-3359	3-5359	3-6359	3-1359	3-7359
300	1000	8° 36'	3.30	3-4229	3-8229	3-2229	3-3229	3-5229	3-6229	3-1229	3-7229
300	2000	17° 27'	3.18	3-4329	3-8329	3-2329	3-3329	3-5329	3-6329	3-1329	3-7329
300	4000	36° 52'	2.67	3-4349	3-8349	3-2349	3-3349	3-5349	3-6349	3-1349	3-7349
600	300	5° 9'	1.66	3-4639	3-8639	3-2639	3-3639	3-5639	3-6639	3-1639	3-7639
600	400	6° 53'	1.66	3-4649	3-8649	3-2649	3-3649	3-5649	3-6649	3-1649	3-7649
600	500	8° 37'	1.65	3-4659	3-8659	3-2659	3-3659	3-5659	3-6659	3-1659	3-7659
600	750	13° 0'	1.62	3-4679	3-8679	3-2679	3-3679	3-5679	3-6679	3-1679	3-7679
600	1000	17° 27'	1.59	3-4619	3-8619	3-2619	3-3619	3-5619	3-6619	3-1619	3-7619
600	1250	22° 1'	1.55	3-4609	3-8609	3-2609	3-3609	3-5609	3-6609	3-1609	3-7609
600	1600	28° 41'	1.46	3-4669	3-8669	3-2669	3-3669	3-5669	3-6669	3-1669	3-7669
830	800	19° 23'	1.14	3-4889	3-8889	3-2889	3-3889	3-5889	3-6889	3-1889	3-7889
830	1200	29° 52'	1.05	3-4819	3-8819	3-2819	3-3819	3-5819	3-6819	3-1819	3-7819
900	500	13° 0'	1.08	3-4719	3-8719	3-2719	3-3719	3-5719	3-6719	3-1719	3-7719
1200	250	8° 37'	0.82	3-4129	3-8129	3-2129	3-3129	3-5129	3-6129	3-1129	3-7129
1200	300	10° 22'	0.82	3-4139	3-8139	3-2139	3-3139	3-5139	3-6139	3-1139	3-7139
1200	400	13° 53'	0.81	3-4149	3-8149	3-2149	3-3149	3-5149	3-6149	3-1149	3-7149
1200	500	17° 27'	0.80	3-4159	3-8159	3-2159	3-3159	3-5159	3-6159	3-1159	3-7159
1200	750	26° 44'	0.74	3-4179	3-8179	3-2179	3-3179	3-5179	3-6179	3-1179	3-7179
1200	1000	36° 52'	0.67	3-4119	3-8119	3-2119	3-3119	3-5119	3-6119	3-1119	3-7119
1800	240	12° 29'	0.54	3-4169	3-8169	3-2169	3-3169	3-5169	3-6169	3-1169	3-7169
1800	500	26° 44'	0.50	3-4189	3-8189	3-2189	3-3189	3-5189	3-6189	3-1189	3-7189

(All dimensions in millimeters) See page 12 for typical efficiency curves.

## High Resolution Holographic Gratings

GROOVES /MM	OPTIMUM EFFICIENCY	DISPERSION (nm/mr)	12.7 x 12.7 x 6	25 x 25 x 6	25 x 25 x 9.5	30 x 30 x 9.5	50 x 50 x 9.5	12.5 x 25 x 6	12.5 x 25 x 9.5	25 x 50 x 9.5
600	UV	1.67 @ 250 NM	3-4027	3-8027	3-2027	3-3027	3-5027	3-6027	3-1027	3-7027
1000	UV	0.99 @ 250 NM	3-4067	3-8067	3-2067	3-3067	3-5067	3-6067	3-1067	3-7067
1200	UV	0.82 @ 250 NM	3-4127	3-8127	3-2127	3-3127	3-5127	3-6127	3-1127	3-7127
1200	VIS	0.79 @ 500 NM	3-4128	3-8128	3-2128	3-3128	3-5128	3-6128	3-1128	3-7128
1800	UV	0.54 @ 250NM	3-4187	3-8187	3-2187	3-3187	3-5187	3-6187	3-1187	3-7187
1800	VIS	0.50 @ 500 NM	3-4188	3-8188	3-2188	3-3188	3-5188	3-6188	3-1188	3-7188
2400	UV	0.40 @ 250 NM	3-4247	3-8247	3-2247	3-3247	3-5247	3-6247	3-1247	3-7247
2400	VIS	0.33 @ 500 NM	3-4248	3-8248	3-2248	3-3248	3-5248	3-6248	3-1248	3-7258
3600	UV	0.25 @ 250 NM	3-4367	3-8367	3-2367	3-3367	3-5367	3-6367	3-1367	3-7367

(All dimensions in millimeters) See page 13 for typical efficiency curves.

## High Resolution Echelle Gratings

GROOVES /MM	BLAZE ANGLE	BLAZE $\lambda$	DISPERSION (nm/mr) @ 500 nm	12.5 x 25 x 6	12.5 x 25 x 9.5	12.5 x 50 x 9.5	25 x 50 x 9.5
31.6	63°	UV - 57 $\mu$	14.37	3-6368	3-1368	3-9368	3-7368
79	63°	UV - 23 $\mu$	5.75	3-6768	3-1768	3-9768	3-7768
79	75°	UV - 25 $\mu$	3.28	3-6778	3-1778	3-9778	3-7778
316	63°	UV - 5.7 $\mu$	1.44	3-6668	3-1668	3-9668	3-7668

(All dimensions in millimeters) See page 13 for typical efficiency curves.

### COATINGS

Protective overcoatings that maintain or enhance reflectivity in the UV, Visible and IR regions are available for an additional charge.

Gold Overcoat (AU-3) ..... Aluminum Magnesium Fluoride (ALMG-3) .....

## TF and UTF Series Gratings and Echelles for Dye Lasers

Replica gratings produced by a proprietary process to withstand high incident energies. Damage thresholds as high as 250 watts/cm<sup>2</sup> for CW sources are available. (For damage threshold specifications see page 9)

### TF and UTF Series Gratings

GROOVES PER MM	BLAZE ANGLE	BLAZE $\lambda$ (nm)	DISPERSION (nm/mr) @ 500 nm	12.7 x 12.7 x 6	25 x 25 x 9.5	30 x 30 x 9.5	50 x 50 x 9.5
<b>TF SERIES</b>							
1200	10° 22'	300	0.82	3-4131	3-2131	3-3131	3-5131
1200	17° 26'	500	0.79	3-4151	3-2151	3-3151	3-5151
1200	26° 45'	750	0.74	3-4171	3-2171	3-3171	3-5171
1200	36° 52'	1000	0.67	3-4111	3-2111	3-3111	3-5111
1800	26° 45'	500	0.50	3-4851	3-2851	3-3851	3-5851
<b>UTF-P SERIES (Pulsed)</b>							
1200	10° 22'	300	0.82	3-4133	3-2133	3-3133	3-5133
1200	17° 26'	500	0.79	3-4153	3-2153	3-3153	3-5153
1200	26° 45'	750	0.74	3-4173	3-2173	3-3173	3-5173
1200	36° 52'	1000	0.67	3-4113	3-2113	3-3113	3-5113
1800	26° 45'	500	0.50	3-4853	3-2853	3-3853	3-5853
<b>UTF-CW SERIES (Continuous)</b>							
1200	10° 22'	300	0.82	3-4134	3-2134	3-3134	3-5134
1200	17° 26'	500	0.79	3-4154	3-2154	3-3154	3-5154
1200	26° 45'	750	0.74	3-4174	3-2174	3-3174	3-5174
1200	36° 52'	1000	0.67	3-4114	3-2114	3-3114	3-5114
1800	26° 45'	500	0.50	3-4854	3-2854	3-3854	3-5854

All dimensions in millimeters.

## TF and UTF Series Gratings - Echelles

GROOVES PER MM	BLAZE ANGLE	BLAZE $\lambda$ (nm)	DISPERSION (nm/mr) @ 500 nm	12.5 x 25 x 6	12.5 x 25 x 9.5	12.5 x 50 x 9.5	25 x 50 x 9.5
<b>TF Series</b>							
31.6	63°	Echelle	14.37	3-6311	3-1311	3-9311	3-7311
316	63°	Echelle	1.44	3-6362	3-1362	3-9362	3-7362
79	75°	Echelle	3.28	3-6771	3-1771	3-9771	3-7771
79	63°	Echelle	5.75	3-6731	3-1731	3-9731	3-7731
<b>UTF-P (Pulsed)</b>							
31.6	63°	Echelle	14.37	3-6313	3-1313	3-9313	3-7313
316	63°	Echelle	1.44	3-6363	3-1363	3-9363	3-7363
79	75°	Echelle	3.28	3-6773	3-1773	3-9773	3-7773
79	63°	Echelle	5.75	3-6733	3-1733	3-9733	3-7733
<b>UTF-CW (Continuous)</b>							
31.6	63°	Echelle	14.37	3-6314	3-1314	3-9314	3-7314
316	63°	Echelle	1.44	3-6364	3-1364	3-9364	3-7364
79	75°	Echelle	3.28	3-6774	3-1774	3-9774	3-7774
79	63°	Echelle	5.75	3-6734	3-1731	3-9734	3-7734

All dimensions in millimeters.

## Grazing Incidence Gratings

Holographic gratings (0.5" x 2") with a typical efficiency of 24%, single pass, and a similarly sized mirror, are suitable for use in the grazing incidence configuration.

Grazing incidence is a simple and inexpensive optical configuration, as described in Applied Optics, July 1978, p. 2224, that can tune and increase the resolution of a dye laser. A holographic grating, functioning as an end reflector in a dye laser cavity, is positioned so that laser radiation strikes the grating almost perpendicular to the grating normal. As the angle of incidence approaches 89 degrees, a relatively large area of the grating is illuminated by the laser beam, increasing angular dispersion and resolving power significantly.

The sizes of the grating and mirror (12.7 mm x 50.8 mm) are optimized for grazing incidence and minimize the cost of the components. The grating is fixed and tuning is achieved by rotation of the mirror. The laser beam is diffracted twice in grazing incidence, resulting in a twofold increase in resolution. Low grating efficiency is characteristic of the grazing incidence configuration but is compensated for by the high gain of the dyes used.

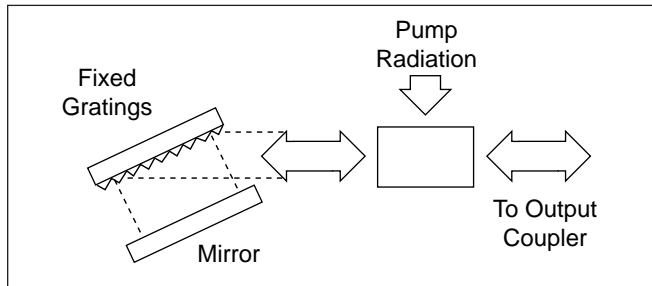

Grazing Incidence Configuration

### SPECIFICATIONS

Grating (replicated holographic):

- Grooves per mm.....1200, 1800, 2400 or 3600
- Dimensional tolerances..... ± 0.5 mm
- Thickness.....9.5 mm ± 0.5 mm
- Clear aperture .....10.0 x 46.0 mm
- Resolution.....80% to 90% of theoretical
- Efficiency at grazing incidence:
  - Single pass.....Approx. 24%
  - Double pass.....Approx. 4%

Mirror:

- Coating.....Al
- Thickness.....9.5 mm ± 0.5 mm

Any standard grazing incidence grating is available with a P-type or CW-type replication coating for higher damage threshold performance (see Page 9 specifications).

## Grazing Incidence Gratings And Mirror

REPLICATED HOLOGRAPHIC GRATING (12.7 x 50.8 mm)					
GROOVES/MM	1200	1800	2400	3600	
BLAZE λ (nm)	Vis	Vis	Vis	UV	
	CATALOG NO.	CATALOG NO.	CATALOG NO.	CATALOG NO.	
NORMAL (TF)	5-2401	5-2402	5-2403	5-2404	
UTF-P (pulsed)	5-2406	5-2407	5-2408	5-2409	
UTF-CW (Continuous)	5-2410	5-2411	5-2412	5-2413	
MIRROR: Used in conjunction with grazing incidence gratings (above) for double pass high resolution tuning of dye lasers.					
12.7 x 50.8 mm	5-2405				

All dimensions in millimeters.

## ML GRATINGS

ML gratings are original rulings or replicas that are normally used as end reflectors for tuning molecular lasers.

The output wavelength of a molecular or dye laser can be tuned by rotating a Littrow mounted grating around an axis parallel to the grooves. The grating equation:

$$n\lambda = d(\sin i + \sin i')$$

where  $n$  is the order of diffraction,  $\lambda$  is the diffracted wavelength,  $d$  is the grating constant (the distance between successive grooves),  $i$  is the angle of incidence measured from the normal and  $i'$  is the angle of diffraction measured from the normal, reduces to  $n\lambda = 2d \sin i$  for the Littrow configuration.

The angle of incidence ( $i$ ) is adjusted to select the output wavelength while creating a narrow gain profile.

## BLAZE ANGLE AND ALIGNMENT

Because the ML series of gratings are designed for peak polarized efficiency, the groove angle is not equivalent to the Littrow blaze angle of the grating. As a result, when using a He-Ne laser for preliminary grating alignment, the brightest He-Ne order will not correspond to the blaze wavelength of the grating. The grating must be aligned using the calculated He-Ne order that corresponds to the wavelength of interest, regardless of its relative intensity.

The blaze arrow marked on the side or back of the grating should be oriented as shown below.

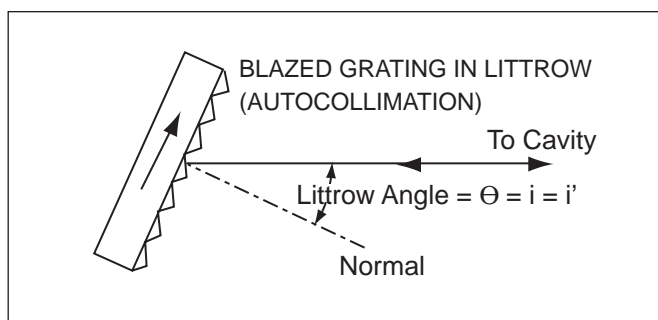

## POLARIZATION

Typical efficiency curves illustrate that, in all cases, orienting the polarization of the E vector (P-Plane) perpendicular to the grooves ( $E_{\perp}$ ) increases the efficiency over a specific wavelength region. This should be considered when optimizing the figure of merit ( $Q$ ) of a cavity, particularly when it is polarized by auxiliary components such as Brewster angle windows.

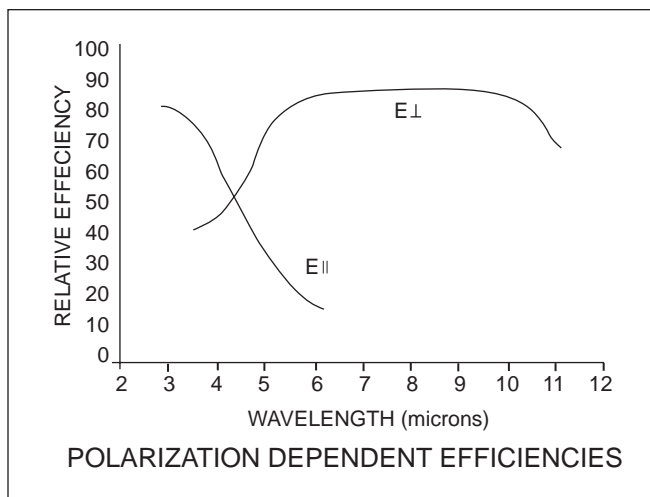

## COATING

ML gratings can be overcoated with gold, increasing the reflectivity at 10.6 microns by approximately 1%, but the damage threshold in high power applications may be reduced. No damage threshold minimums apply for overcoated gratings.

**Also available as original gratings, ruled directly into an aluminum or gold coating deposited on a copper substrate resulting in an inherently higher damage threshold. They are recommended for use with high power lasers.**

**See our Laser Optics Products brochure.**

## Summary ML Grating Specifications

MODEL NO.	GROOVES/ MM	MIN. POLARIZED ABS. EFFICIENCY	OPTIMUM RANGE ( $\mu$ ) (nm/m $\mu$ )	ANGULAR DISPERSION
ML-301	75	≥ 88%	9.0 - 11.0	12.3
ML-302	100	≥ 88%	9.0 - 11.0	8.5
ML-303	150	≥ 88%	9.0 - 11.0	4.2
ML-304	135	≥ 88%	9.0 - 11.0	5.2
ML-401	150	≥ 88%	5.0 - 6.0	6.1
ML-402	300	≥ 82%	5.0 - 6.0	2.0
ML-501	300	≥ 80%	2.5 - 3.0	3.0
ML-502	450	≥ 85%	2.0 - 4.0	1.6
ML-601	300	≥ 80%	2.5 - 4.0	0.35
ML-701	90	≥ 88%	16.0 - 20.0	7.7

## SPECIFICATIONS

Clear aperture.....	90%
Grooves parallelism to edge .....	± 0.5°
Dimensional tolerances .....	± 0.5 mm
Thickness:	
Originals.....	10 mm ± 0.5 mm
Replicas .....	9.5 mm ± 0.5 mm
Damage threshold:	
Original gratings:	
CW laser .....	1 KW/cm <sup>2</sup>
Pulse laser (100 nsec pluse) .....	7 J/cm <sup>2</sup>
Replicated gratings:	
CW laser .....	250 W/cm <sup>2</sup>
Pulsed laser (200 nsec pulse) .....	3.5 J/cm <sup>2</sup>

\*See our website for typical efficiency curves.

## ML Series Gratings

ML (Molecular laser) Series replicated ruled gratings are used primarily to tune the output wavelength of high powered lasers. High peak efficiencies, typically from 92%–96%, are achieved by orientating the polarization of the “E” vector perpendicular to the grooves rather than the unpolarized average. Original MLs are ruled directly into an aluminum coating on a copper substrate, resulting in an inherently high damage threshold. Standard MLs are available in a number of blaze wavelengths (2.8  $\mu$  to 16.0  $\mu$ ) and groove spacings (75 g/mm to 450 g/mm).

## ML Grating Replicas - Rectangles

MODEL NO.	12.5 x 25 mm REPLICA CAT. NO.	25 x 50mm REPLICA CAT. NO.	1" x .825" REPLICA CAT. NO.
ML-301	5-3810	5-3113	5-3118
ML-302	5-3820	5-3123	5-3128
ML-303	5-3630	5-3830	5-3138
ML-304	5-3840	5-3143	5-3148
ML-401	5-4810	5-4113	5-4118
ML-402	5-4820	5-4123	5-4128
ML-501	5-5810	5-5113	5-5118
ML-502	5-5820	5-5123	5-5128
ML-601	5-6810	5-6113	5-6118
ML-701	5-7810	5-7113	5-7118

## ML Grating Replicas - Squares

MODEL NO.	25 x 25 mm REPLICA CAT. NO.	30 x 30 mm REPLICA CAT. NO.	50 x 50 mm REPLICA CAT. NO.	58 x 58 mm REPLICA CAT. NO.
ML-301	5-3112	5-3119	5-3115	5-3116
ML-302	5-3122	5-3129	5-3125	5-3126
ML-303	5-3132	5-3139	5-3135	5-3136
ML-304	5-3142	5-3149	5-3145	5-3146
ML-401	5-4112	5-4119	5-4115	5-4116
ML-402	5-4122	5-4129	5-4125	5-4126
ML-501	5-5112	5-5119	5-5115	5-5116
ML-502	5-5122	5-5129	5-5125	5-5126
ML-601	5-6112	5-6119	5-6115	5-6116
ML-701	5-7112	5-7119	5-7115	5-7116

## ML Grating Replicas - Diameters

MODEL NO.	25 mm DIA. REPLICA CAT. NO.	38 mm DIA. REPLICA CAT. NO.	50 mm DIA. REPLICA CAT. NO.
ML-301	5-3111	5-3117	5-3114
ML-302	5-3121	5-3127	5-3124
ML-303	5-3131	5-3137	5-3134
ML-304	5-3141	5-3147	5-3144
ML-401	5-4111	5-4117	5-4114
ML-402	5-4121	5-4127	5-4124
ML-501	5-5111	5-5117	5-5114
ML-502	5-5121	5-5127	5-5124
ML-601	5-6111	5-6117	5-6114
ML-701	5-7111	5-7117	5-7114

# Diffraction Gratings | Typical Efficiency Curves-ML Gratings

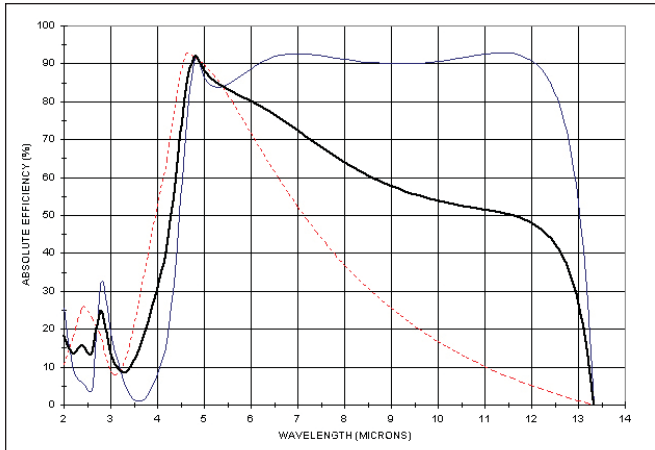

150 g/mm, blazed at 10.6  $\mu$  (E.L)  
Angular dispersion 2.0 nm/mr

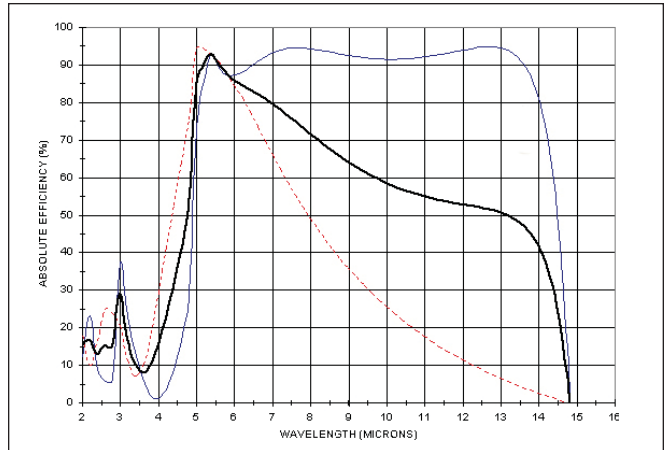

135 g/mm, blazed at 10.6  $\mu$  (E.L)  
Angular dispersion 2.0 nm/mr

## COATINGS

ML gratings can be overcoated with gold, increasing the reflectivity at 10.6 microns by approximately 1%, but the damage threshold in high power applications may be reduced. No damage threshold minimums apply for overcoated gratings.

Gold Overcoat (AU-3) .....

- — — — — Perpendicular Polarization
- ..... Parallel Polarization
- Average

### Efficiency Curve Key

- All gratings are measured in the Littrow mounting in 1st order
- All gratings utilize an aluminum (Al) reflective coat

These are several of Optometrics grating efficiency curves.

# Transmission Gratings - Visible & NIR | Diffraction Gratings

New line of replicated gratings, specifically designed for use in transmission...

Transmission gratings offer a basic simplicity for optical designs that can be beneficial in fixed grating applications such as spectrographs. The incident light is dispersed on the opposite side of the grating at a fixed angle. Transmission gratings are very forgiving for some types of grating alignment errors.

By necessity, transmission gratings require relatively coarse groove spacings to maintain high efficiency. As the diffraction angles increase with the finer spacings, the refractive properties of the materials used limit the transmission at the higher wavelengths and performance drops off. The grating dispersion characteristics, however, lend themselves to compact systems utilizing small detector arrays. The gratings are also relatively polarization insensitive.

## TRANSMISSION GRATINGS: VISIBLE & NIR

This line of blazed transmission gratings was designed for optimum performance in the visible and NIR spectrum, offering different levels of dispersion. In most cases, the efficiency is comparable to that of reflection gratings typically used in the same region of the spectrum.



## TYPICAL SPECIFICATIONS-VISIBLE & NIR

Substrate material.....Schott B270  
 Thickness.....3mm nominal  
 Dimensional tolerances..... $\pm 0.5$ mm  
 Thickness tolerances..... $\pm 0.5$ mm

Performance Comparison Various Visible Tx Gratings

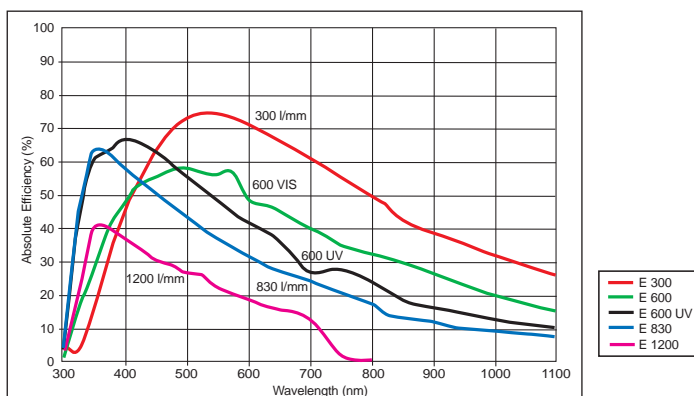

Performance Comparison for NIR Tx Grating

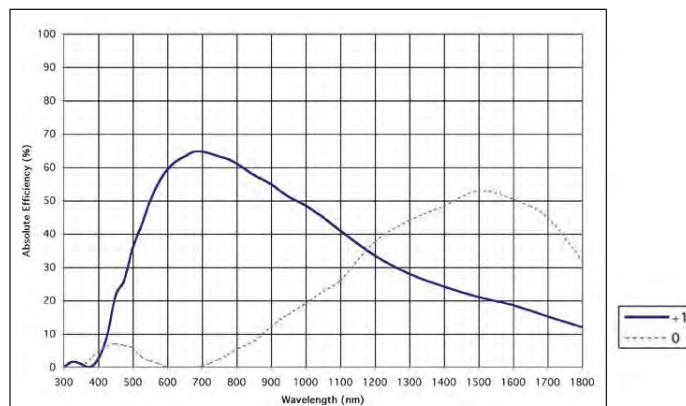

300/24.8 Degree Tx Grating

Performance Comparison for NIR Tx Grating

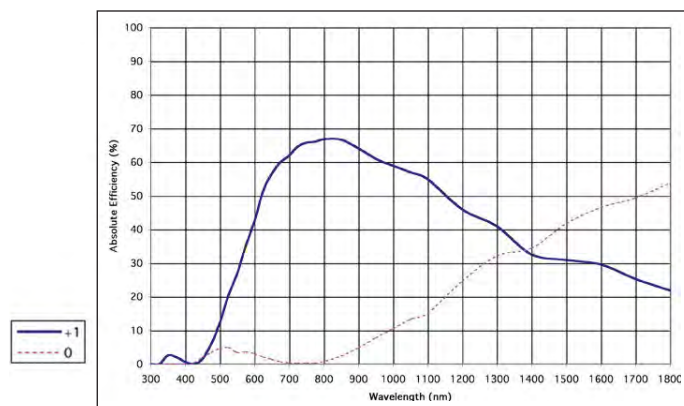

300/31.7 Degree Tx Grating

All gratings measured at zero degree angle of incidence

## Transmission Gratings - Visible

Size (mm)	300 g/mm 17.5°	600 g/mm 28.7° (VIS)	600 g/mm 22° (UV)	830 g/mm 29.87°	1200 g/mm 36.9°	
12.7 x 12.7	3-9801	3-9807	3-9813	3-9819	3-9825	
12.7 x 12.7 (AR)	3-9901	3-9907	3-9913	3-9919	3-9925	
25 x 25	3-9802	3-9808	3-9814	3-9820	3-9826	
25 x 25 (AR)	3-9902	3-9908	3-9914	3-9920	3-9926	
30 x 30	3-9803	3-9809	3-9815	3-9821	3-9827	
30 x 30 (AR)	3-9903	3-9909	3-9915	3-9921	3-9927	
50 x 50	3-9804	3-9810	3-9816	3-9822	3-9828	
50 x 50 (AR)	3-9904	3-9910	3-9916	3-9922	3-9928	
12.5 x 25	3-9805	3-9811	3-9817	3-9823	3-9829	
12.5 x 25 (AR)	3-9905	3-9911	3-9917	3-9923	3-9929	
25 x 50	3-9806	3-9812	3-9818	3-9824	3-9830	
25 x 50 (AR)	3-9906	3-9912	3-9918	3-9924	3-9930	

## Transmission Gratings - NIR

Size (mm)	300 g/mm 31.7°	300 g/mm 24.8°	
12.7 x 12.7	3-9201	3-9207	
25 x 25	3-9202	3-9208	
30 x 30	3-9203	3-9209	
50 x 50	3-9204	3-9210	
12.5 x 25	3-9205	3-9211	
25 x 50	3-9206	3-9212	

Transmission gratings can be made with AR coatings. In addition to increasing the throughput of the grating, an AR coating eliminates any secondary spectra concerns caused by the back surface reflection. Please note, however, that AR coatings are designed for peak performance at a specific wavelength and may detract from grating efficiency outside the design wavelength range.

# Transmission Gratings - UV | Diffraction Gratings

## TRANSMISSION GRATINGS - UV

New UV Transmission Gratings are available in standard sizes. They are manufactured with carefully selected UV materials allowing for optimal performance down to 235 nm. Zero order data is included in all performance curves for those interested in beam splitting applications.

## TYPICAL SPECIFICATIONS - UV

Substrate material ..... UV grade fused silica  
 Thickness ..... 2mm nominal  
 Dimensional tolerances .....  $\pm 0.5$ mm  
 Thickness tolerances .....  $\pm 0.2$ mm

Transmission gratings can be made with AR coatings. In addition to increasing the throughput of the grating, an AR coating eliminates any secondary spectra concerns caused by the back surface reflection. Please note, however, that AR coatings are designed for peak performance at a specific wavelength and may detract from grating efficiency outside the design wavelength range.

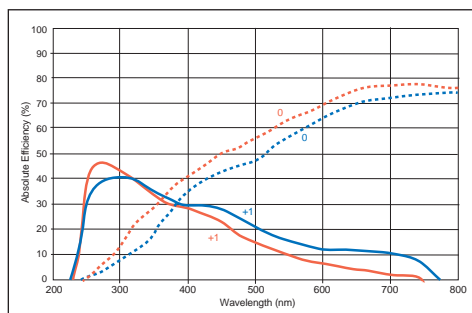

1200 UV Tx Gratings

830 UV Tx Gratings

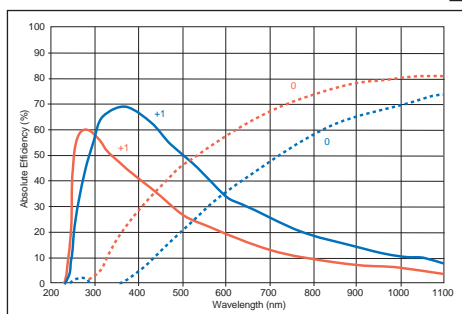
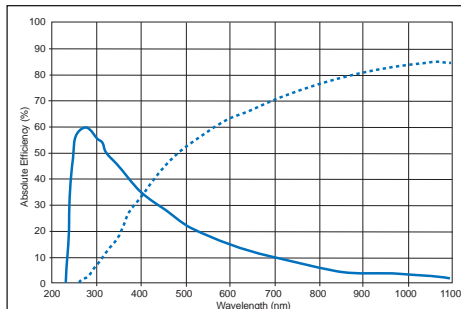
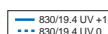

600 UV Tx Gratings

300 UV Tx Gratings

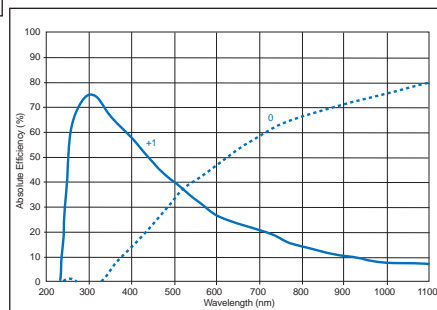

All gratings measured at zero degree angle of incidence.

## Transmission Gratings - UV

Size (mm)	300 g/mm 8.6"	600 g/mm 22"	600 g/mm 17.5"	830 g/mm 19.4"	1200 g/mm 36.9"	1200 g/mm 26.7"	
12.7 x 12.7	3-9401	3-9411	3-9421	3-9431	3-9441	3-9451	
25 x 25	3-9402	3-9412	3-9422	3-9432	3-9442	3-9452	
30 x 30	3-9403	3-9413	3-9423	3-9433	3-9443	3-9453	
50 x 50	3-9404	3-9414	3-9424	3-9434	3-9444	3-9454	
12.5 x 25	3-9405	3-9415	3-9425	3-9435	3-9445	3-9455	
25 x 50	3-9406	3-9416	3-9426	3-9436	3-9446	3-9456	

# Diffraction Gratings | Reflecting Beam Dividers/Combiners

The reflecting beam divider/combiner is constructed like a replica micro mirror array with 4 facet pairs per mm and a reflective aluminum coating, giving it broadband performance from 200 nm to the far infrared. The measurements at the visible wavelength and those in the IR differ only because of the inherent characteristics of aluminum. All data can be taken as representative within 2% and the reflected beams ( $R_D$ ) are equal to each other within  $\pm 2\%$ . This data is valid by the same margin for either or both polarizations.

The surfaces are ruled with equally spaced grooves of 4 per mm, producing the symmetrical triangular profile which permits good beam concentration. The facet surfaces of the grooves are highly reflective, allowing these divider/combiners to be used from

the UV to the far infrared. These divider/combiners are recommended for dividing/combining broadband sources. Not recommended for imaging or interferometric applications.

Operating range.....UV to far infrared  
 Spacing.....4 per mm  
 Groove profile.....Symmetrical  
 Substrate.....Pyrex  
 Efficiency.....Typically 80%  
 Standard angles.....30°, 45°, 60°  
 Damage threshold,  
 pulsed.....350 milli-joules/cm<sup>2</sup> @ 200 nsec.  
 Damage threshold, CW.....40 watts/cm<sup>2</sup>  
 Standard sizes.....25 mm sq., 50 mm sq.  
 Thickness.....6.0 mm  $\pm$  0.5 mm

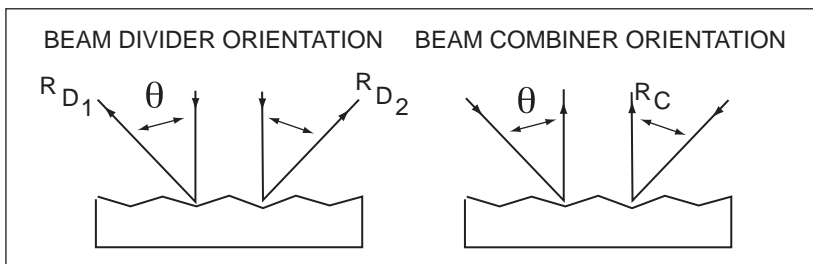

## Reflecting Beam Dividers or Combiners

Ruled with equally spaced grooves of 4 per mm produces the symmetrical triangular profile which permits good beam concentration and gives it broadband performance from 200 nm to the far IR.

BEAM ANGLE $\theta$	SIZE (mm)	CATALOG NO.
30°	25 x 25	4-2430
45°	25 x 25	4-2445
60°	25 x 25	4-2460
30°	50 x 50	4-5430
45°	50 x 50	4-5445
60°	50 x 50	4-5460

	6328A		10.6 $\mu$	
	$R_D$	$R_C$	$R_D$	$R_C$
$\theta = 30^\circ$ Beam Divider	40%	40%	45%	45%
$\theta = 45^\circ$ Beam Divider	40%	57%	45%	65%
$\theta = 60^\circ$ Beam Divider	40%	76%	45%	85%

# Transmission Grating Beamsplitters | Diffraction Gratings

Transmission grating beamsplitters are commonly used for laser beam division and multiple laser line separation in visible wavelengths. The transmitted beam is diffracted into multiple orders.

Optometrics' transmission grating beamsplitters consist of an index matched epoxy replica on a polished glass substrate for a high total efficiency. These beamsplitters were designed specifically for useful division of He-Ne lasers.

Several gratings are available offering different dispersion and power distributions. The diffraction angle for any wavelength may be calculated using the grating equation for normal incident light.

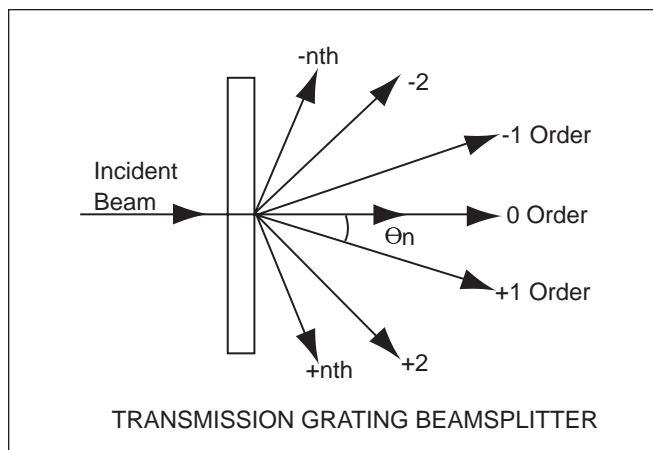

Transmission Grating Beamsplitter

Grating Equation:

$$\theta_n = \sin^{-1} \left( \frac{n\lambda}{d} \right)$$

Where:

- $\theta_n$  = diffraction angle for the nth order
- n = diffracted order
- $\lambda$  = wavelength of light
- d = grating period

## GENERAL SPECIFICATIONS

- Material..... Schott B270
- Size..... 25 mm square maximum
- Thickness ..... 3 mm nominal
- Tolerances .....  $\pm 0.5$  mm

## Transmission Grating Beamsplitters

Used for He-Ne laser beam division and multiple laser line separation in visible wavelengths, the transmitted beam is diffracted into multiple orders.

He-Ne DIFFRACTED ORDER TYPICAL DISTRIBUTION @ 632.8 nm (%)						12.7 x 12.7 mm CATALOG NO.	25 x 25 mm CATALOG NO.
L/MM	-2	-1	0	+1	+2		
70	-	-	41	32	-	4-1270	4-2570
80	5	25	25	25	5	4-1280	4-2580
92	-	20	45	20	-	4-1292	4-2592
110	-	25	28	25	-	4-1211	4-2511

## COATINGS

Protective overcoatings that maintain or enhance reflectivity in the UV, Visible and IR regions are available for an additional charge.

Gold Overcoat (AU-3) .....

Aluminum Magnesium Fluoride (ALMG-3) .....



## “Polka Dot” Beamsplitters

### Reflecting/Transmitting Beam Splitters on UV Grade Fused Silica

90/10	80/20	70/30	60/40	50/50	40/60	30/70	20/80	SIZE	
4-9001	4-8011	4-7001	4-6001	4-0001	4-0461	4-0371	4-2001	25.4 Dia.	
4-9002	4-8012	4-7002	4-6002	4-0002	4-0462	4-0372	4-2002	25.4 x 25.4	
4-9003	4-8013	4-7003	4-6003	4-0003	4-0463	4-0373	4-2003	38.0 Dia.	
4-9004	4-8014	4-7004	4-6004	4-0004	4-0464	4-0374	4-2004	38.0 x 38.0	
4-9005	4-8015	4-7005	4-6005	4-0005	4-0465	4-0375	4-2005	50.8 Dia.	
4-9006	4-8016	4-7006	4-6006	4-0006	4-0466	4-0376	4-2006	50.8 x 50.8	
4-9007	4-8017	4-7007	4-6007	4-0007	4-0467	4-0377	4-2007	12.7 Dia.	

### Reflecting/Transmitting Beam Splitters on B270 Glass

90/10	80/20	70/30	60/40	50/50	40/60	30/70	20/80	SIZE	
4-9101	4-8101	4-7101	4-6101	4-0101	4-4161	4-3101	4-2101	25.4 Dia.	
4-9102	4-8102	4-7102	4-6102	4-0102	4-4162	4-3102	4-2102	25.4 x 25.4	
4-9103	4-8103	4-7103	4-6103	4-0103	4-4163	4-3103	4-2103	38.0 Dia.	
4-9104	4-8104	4-7104	4-6104	4-0104	4-4164	4-3104	4-2104	38.0 x 38.0	
4-9105	4-8105	4-7105	4-6105	4-0105	4-4165	4-3105	4-2105	50.8 Dia.	
4-9106	4-8106	4-7106	4-6106	4-0106	4-4166	4-3106	4-2106	50.8 x 50.8	
4-9107	4-8107	4-7107	4-6107	4-0107	4-4167	4-3107	4-2107	12.7 Dia.	

## Spectroscopic Grating Kits

These spectroscopic grating kits, covering the UV to the near IR, each contain four (4) diffraction gratings, covering the 250nm to 1.2  $\mu$  wavelength range. Choose either a 600 groove per mm or a 1200 groove per mm kit in a choice of two sizes.

Grooves per mm/Blaze Wavelength	Kit Comprised of 1 each of	
	12.7mm	25mm
600/300nm	3-4630	3-2630
600/500nm	3-4650	3-2650
600/750nm	3-4675	3-2675
600/1.0 micron (1,000nm)	3-4610	3-2610
<b>Kit Catalog No.</b>	<b>3-0101</b>	<b>3-0102</b>

Grooves per mm/Blaze Wavelength	Kit Comprised of 4 each of	
	12.7mm	25mm
1200/300nm	3-4130	3-2130
1200/500nm	3-4150	3-2150
1200/750nm	3-4175	3-2175
1200/1000nm (1.0 $\mu$ )	3-4110	3-2110
<b>Kit Catalog No.</b>	<b>3-0201</b>	<b>3-0202</b>

### GENERAL SPECIFICATIONS

Material..... BK7 or float glass or equivalent  
 Size..... 12.7 mm square or 25mm square  
 Thickness .....6mm - 9.5mm  
 Dimensional tolerances .....  $\pm$  0.5 mm  
 Efficiency .....60-80% at blaze wavelength

Refer to the grating matrix on Page 10 for detailed specifications for each of the gratings included in each kit.