

## LUXXMASTER® 532 nm Multimode Butterfly Package

PD-LD's 532 nm laser Butterfly package is a fiber pigtailed wavelength stabilized source that supports customers requiring a low cost, visible wavelength, narrow line width and easy to use laser. For example, historically, Raman applications needing a line width less than 0.3 nm had to rely on expensive and bulky laser sources. The 532nm Butterfly provides an alternative that is compact, robust and easy to implement into your existing applications. The small size and simple interface makes it perfect for many industrial, military and security applications.

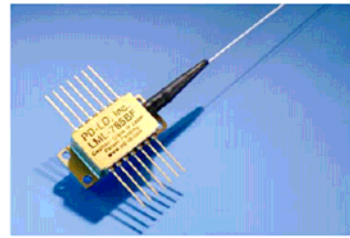

Figure 1: PDL BUTTERFLY PACKAGE

### Major Features:

- 532 nm
- $\lambda_c = \pm 1$  nm
- Line width ~ 0.3 nm
- 50 to 100mW into MMF
- Simple to use
- Compact size

### OPTICAL & ELECTRICAL SPECIFICATIONS

Parameter	Unit	Minimum	Typical	Maximum
Center Wavelength	nm	531	532	533
Output Power <sup>A</sup>	mW		50	100
Peak to Peak Power Stability <sup>B</sup>	%		3	
Operating Voltage	Volts	1.9		2.1
Operating Current	Amps		0.6	1.30
Threshold Current	Amps		0.3	
Spectral Line width (FWHM)	nm		0.3	
TEC Current	Amps			2
TEC Voltage	Volts			4
TEC SET TEMPERATURE <sup>C</sup>	°C	10	20	40
Fiber Type	1m long MMF 105/125/900 micron			
Connector Type	FC/APC standard and other connectors available upon request			
NOTES:	<p>A. Output power is pre-set to the customer's specification.</p> <p>B. At a set TEC temperature. Based on 100 hrs.</p> <p>C. Package must be run with a <b>SET</b> TEC temperature. This is the TEC inside the package. Value is expected to be within the range specified. Range does not imply that the TEC can be set to any temperature within the range.</p>			



# LUXMASTER® 532 nm Multimode Butterfly Package

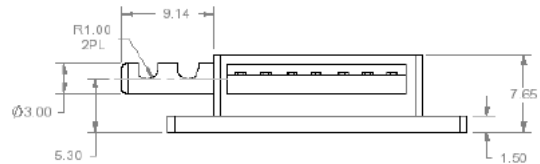
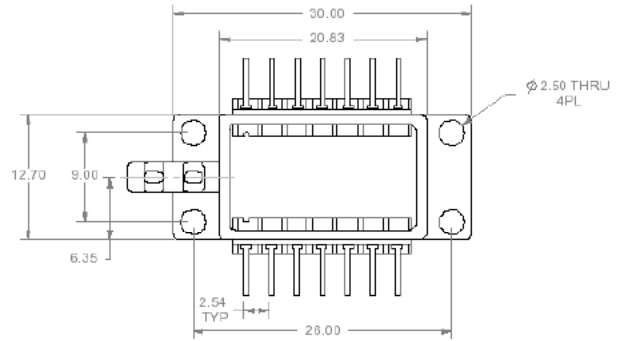
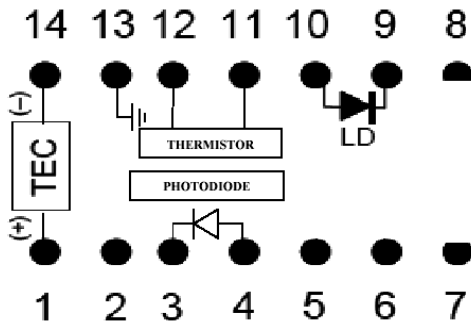

PIN NO.	ASSIGNMENT	PIN NO.	ASSIGNMENT
1	TEC ANODE (+)	8	OPEN
2	OPEN	9	LASER CATHODE (-)
3	PD CATHODE	10	LASER ANODE (+)
4	PD ANODE	11	THERMISTOR
5	OPEN	12	THERMISTOR
6	OPEN	13	CASE GND
7	OPEN	14	TEC CATHODE (-)

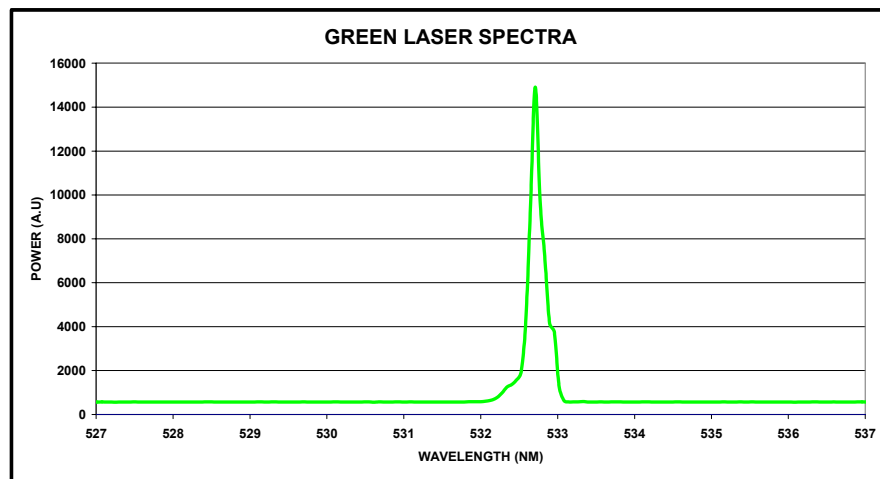

**Part Number:**

**LML-532.0BF-xx**

**LML:** Luxxmaster® Laser

**532.0:** wavelength

**BF:** Butterfly package

**xx:** Specific customer reference

Specifications Subject to Change

01/17/2011