

This data sheet describes wavelength stabilized high power 785nm laser series in a coaxial package with collimated output. It is built utilizing PD-LD's patented Volume Bragg Grating® (VBG®) technology. This package includes a multiple transverse mode laser chip mounted and hermetically sealed inside a TO-9 or a TO-56 package. The laser TO can is then integrated into a copper heat sink for optimal optical & thermal performance. The laser output is collimated using an aspheric lens and optically stabilized using a VBG® element. This laser package includes optical isolation and a narrowband laser line filter for superior stability against back reflections and a high level of ASE suppression – features critical for Raman spectroscopy applications.



Figure 1: LuxxMaster® coaxial high powerpackage

Superior Performance:

- Wavelength accuracy: ± 0.5 nm
- Line Width: < 1 cm⁻¹
- Wide temperature range: ± 15 C
- Low wavelength drift: 8 pm/C
- Adjustable output power

Advantages:

- High power
- Optically isolated
- Economical
- Includes laser clean-up filter
- Fast on-wavelength turn-on

Applications:

- Sensing
- Raman Spectroscopy
- Medical
- Military

Operational Specifications

Parameter	Unit	Minimum	Typical	Maximum
Center Wavelength ^A	nm	784.5	785	785.5
Wavelength Stability ^B	pm			5
Output Power	mW	100	500	1000
Beam divergence: fast axis	Deg		0.3	0.5
Beam divergence: slow axis			3	5
Operating Voltage	V	1.9		2.1
Operating Current	mA		750	1500
Threshold Current	mA		0.43	0.5
Slope Efficiency	W/A		0.5	
Spectral Line Width (FWHM)	nm		0.05	0.07
	cm ⁻¹		0.8	1.13
Operating Case Temperature ^C	°C	10	25	40
NOTES:	<i>A. Other wavelengths are available. Contact sales.</i>			
	<i>B. Short-term stability at a constant case temperature.</i>			
	<i>C. The quoted temperature range represents a typical temperature range within which laser remains locked on wavelength.</i>			

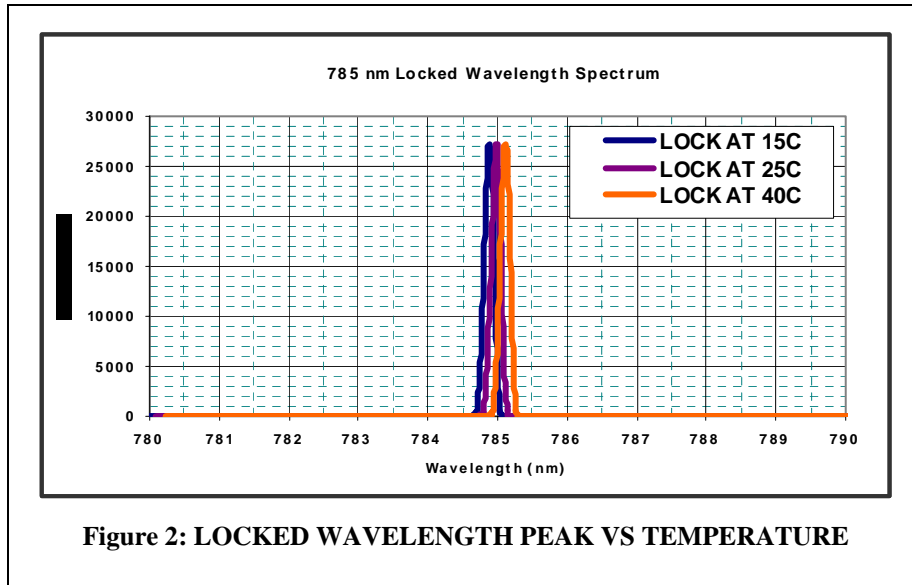
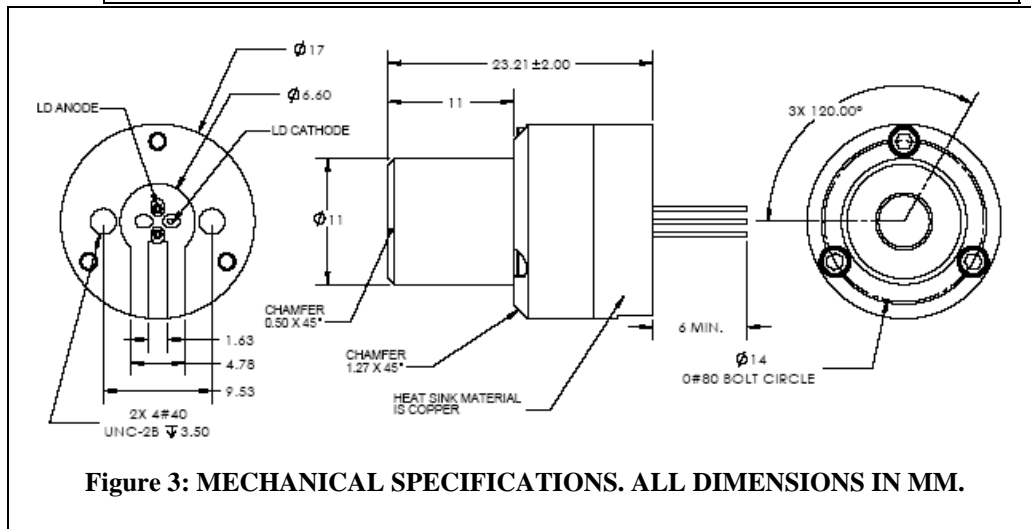

Figure 2: LOCKED WAVELENGTH PEAK VS TEMPERATURE



Part Number System

LML-___-T9-XX

- ___ indicates the wavelength.
- T9 indicates TO-9 package.
- XX is a customer specific reference.

Example: LML-785.0T9-XX. This is a LuxxMaster® Laser with a center wavelength of 785 nm in a TO-9 package.

