

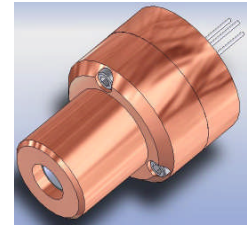

COAXIAL VBG LOCKED PACKAGE W/INTEGRATED HEAT SINK

The LuxxMaster[®] wavelength stabilized 785nm laser is a VBG[®] locked package integrated into a heat sink for optimal optical & thermal performance. It is built using patent pending Volume Bragg Grating[®] (VBG[®]) technology, which is used for stabilizing and shaping the emission spectra of laser diodes.



Superior Performance:

- $\lambda_c = \pm 0.5 \text{ nm}$
- Line Width $\sim 0.1 \text{ pm}$
- Wide temperature range
- Low Temperature drift of $\sim 0.01 \text{ nm/C}$

Advantages:

- Integrated Heat Sink
- Economical
- Ease of System Integration

Applications:

- Sensing
- Spectroscopy
- Medical
- Military

Operational Specifications

Parameter	Unit	Minimum	Typical	Maximum
Center Wavelength	nm	784.5	785	785.5
Output Power	mWatts	60	-	-
Operating Voltage	Volts	1.9		2.1
Operating Current	mA		150	180
Threshold Current	mA		35	50
Line width	pm / MHz		0.1 / 50	
Operating Temperature with Stabilization	°C	15	25	40
Beam Divergence	Deg		0.30	0.50

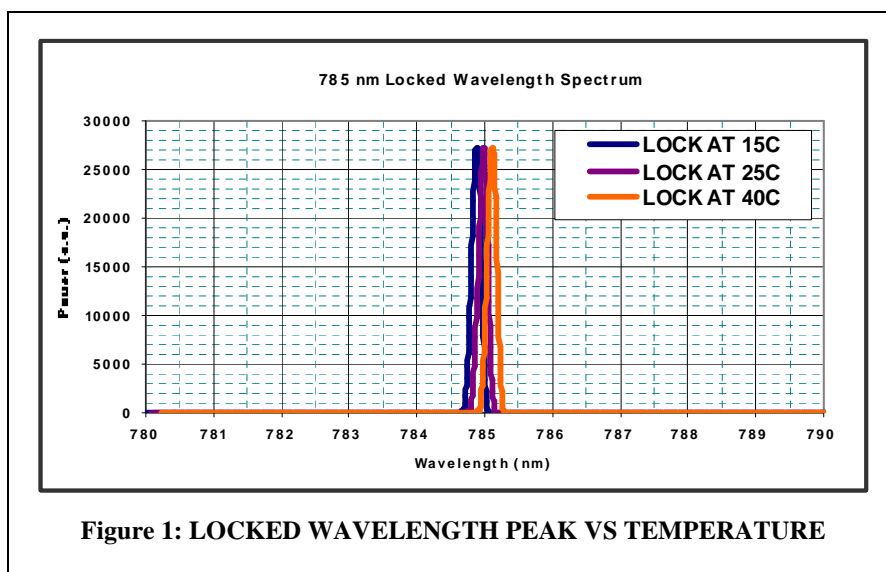

Specifications Subject to Change

09/04/08

COAXIAL VBG LOCKED PACKAGE W/INTEGRATED HEAT SINK

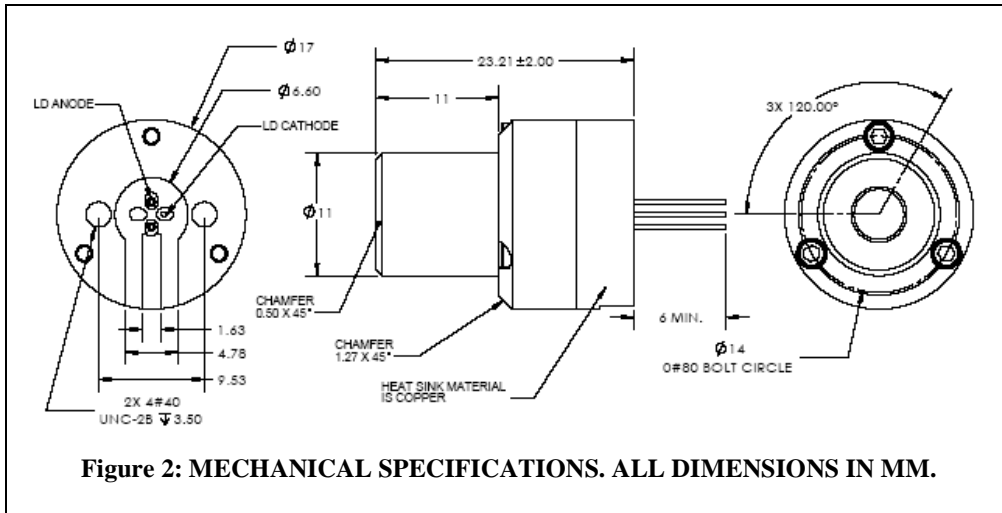

Part Number System

LML-____-T9-XX

- ____ indicates the wavelength.
- T9 indicates TO-9 package.
- XX is a customer specific reference.

Example: LML-785.0T9-XX. This is a LuxxMaster® Laser with a center wavelength of 785 nm in a TO-9 package.

