



PL 780nm Series Near IR Laser Diode Modules

PD-LD Inc. offers a variety of packaging options for its' 780nm Series of laser diodes. These units are available in ready-to-use, fiber-coupled packages, including FC, ST, and SC receptacles, as well as fiber-pigtailed units.

The laser diodes offered by PD-LD feature standard wavelength options centered at 780nm, 830nm and 980nm. Fiber-coupled CW (continuous-wavelength) output powers range from 0.1 - 10 mW, depending on the fiber type and desired performance level. Devices may be optimized for coupling to sensor or telecommunication size optical fiber, from 5um to 200um core.



Fiber Size and Coupling Efficiency

- 5/125um 8~15%
- 9/125um 15~20%
- 50/125um 25~30%
- 62.5/125um 30~40%
- 100/140um 40~50%

Applications

- Fiber optic communications
- Optical Sensing
- Process Control
- Test and Measurement
- Optical Alignment Systems
- Medical Apparatus
- Imaging and Scanning Systems

Performance Specifications: Typical Product Configurations (more options available)

PD-LD Part No. ¹	Wavelength (nm)			Min. Fiber Coupled Power (mW)	Pin-out TO Dia (mm)	Threshold Current (mA)		Operating Current (mA)		Monitor PD Current (mA)	
	Min.	Typ.	Max.			Typ.	Max.	Typ.	Max.	Min.	Typ.
Continuous Wavelength Lasers @ 25C											
PL78C0.51FCB-T-0-01	770	785	810	0.5mW into 9/125 SMF	M 5.6	35	60	45	70	0.1	0.6
PL78G0017STA-0-0-01	770	780	795	1.0mW into 5/125um SMF	N 5.6	10	15	30	50	0.3	0.6
PL78H0037FCD-U-0-01	775	785	795	3mW Into 5/125 MMF	N 9.0	45	70	140	170	0.025	0.15
PL78J001ST73-T-0	770	785	795	1mW into 62.5/125um MMF	N 5.6	20	30	35	70	0.3	0.55
PL78K0011FCA-0-0-01	770	785	795	1mW into 9/125um SMF	Internal Driver	NA		NA		NA	
PL78M001FC11-T-0	770	780	800	1 mW into 9/125 SMF	P 9.0	25	40	40	70	0.45	0.9
PL78N060D00A-0-0-01	770	785	795	60mW into 105/125um MMF	N 5.6	25	35	90	160	0.10	0.50
PL78R0012STA-0-0-01	770	785	795	1 mW ST Receptacle	N 5.6	25	45	45	65	0.3	0.55

¹Examples only; most device/packaging combinations available.

Changes to specifications may be made without notice. 03-11 780Series .Rev A



PL 780nm Series Near IR Laser Diode Modules

Packaging Options: Optional board- or panel -mount flanges are available for pigtailed devices; contact PD-LD Sales. Also, PD-LD Inc. will package non-standard lasers or parts specified by a customer using standard or custom receptacle or pigtailed techniques. Both receptacle and pigtail packages are made using an active micro-positioning system and proven packaging techniques. Reliable and efficient devices are produced.

In many cases several different pin-out options are available for similar wavelength lasers.

Bottom View

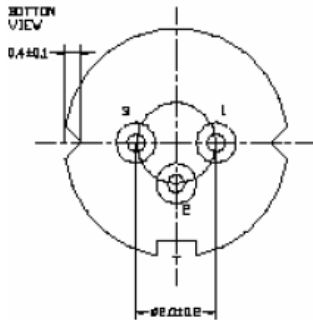

“N” Pin-out	Laser Diode Anode + Photodiode Cathode
“M” Pin-out	Laser Diode Cathode + Photodiode Cathode
“P” Pin-out	Laser Diode Cathode + Photodiode Anode

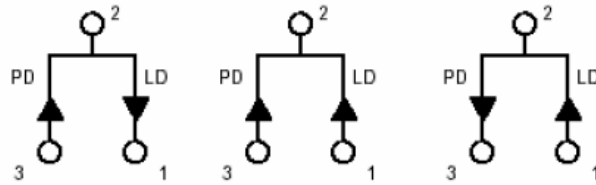

“N” Pin-out

“M” Pin-out

“P” Pin-out

¹Examples only; most device/packaging combinations available.

Changes to specifications may be made without notice. 03-11 780Series .Rev A



PL 780nm Series Near IR Laser Diode Modules

PD-LD Laser Code	Nominal Wave- length (nm)	TO Package Size	Laser Pinning	Maximum Total Power (mW)*
78C	785nm -15/+25nm +80° Operation	5.6mm	M	5.0
78G	785nm +10/-15nm	5.6mm	N	10.0
78H	785nm +/-10nm	9.0mm	N	50.0
78J	780nm +15/-10nm	5.6mm	N	3.0
78K	785nm +10/-15nm	5.6mm	Internal Driver	5.0
78M	785 +/-15nm +60° Operation	9.0mm	P	5.0
78N	785nm +/-10nm	5.6mm	N	100.0
78Q	785nm -15/+25nm +60° Operation	5.6mm	P	5.0
78R	785nm -15/+25nm +60° Operation	5.6mm	N	5.0

***The power listed is the total light output from the semiconductor laser chip as measured from the discreet TO package. The amount of light coupled into the optical fiber will be dependent on the fiber type.**

- Please contact PD-LD Sales to discuss wavelength, pinning and power requirements not listed above.**

¹Examples only; most device/packaging combinations available.

Changes to specifications may be made without notice. 03-11 780Series .Rev A



PL 780nm Series Near IR Laser Diode Modules

Data Legend: Pigtailed 780nm Lasers

PL WWW PPP F CC B-O-V-LL

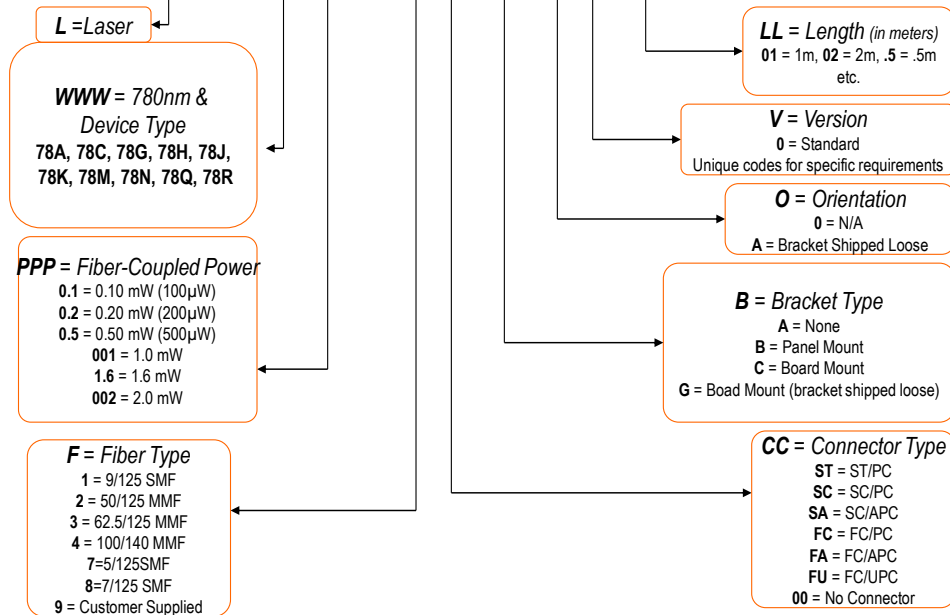

Data Legend: Receptacle 780nm Region Laser Diodes

Ex: PL WWW PPP RRR F-O-V

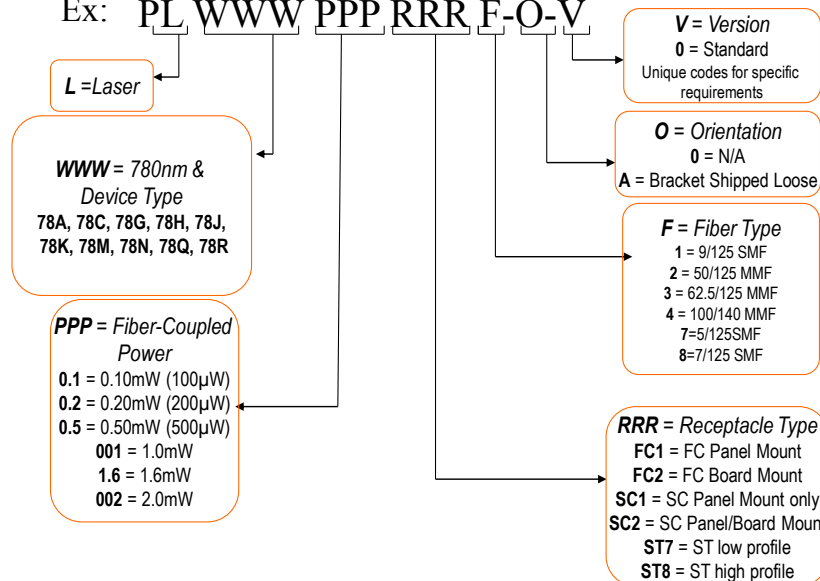

¹Examples only; most device/packaging combinations available.
www.lasercomponents.com

Changes to specifications may be made without notice. 03-11 780Series .Rev A
07/11 / V1 / SB / pd_id/ pl78.pdf