



155 Mbps Bi-directional Multimode 1x9 Transceiver PTR155-B35/B53-M

Features

- RoHS compliant
- Compatible with 155 Mbps ATM and SONET OC-3 SDH STM-1
- Industry standard 1x9 footprint
- SC Connector
- Single power supply 3.3 V
- Differential PECL inputs and outputs
- Compatible with solder and aqueous wash processes
- Class 1 laser product complies with EN 60825-1

PD-LD Inc. offers multimode laser based fiber optic transceiver modules in convenient industry standard 1x9 style packages. The PTR155 series modules are designed to comply with SONET/SDH 155 Mbps operation over 62.5/125um multimode optical fiber.

A 1310 nm (-B35) or 1550nm (-B53) FP laser and an InGaAs PIN photodiode are integrated with a WDM filter to form a bi-directional single fiber optical subassembly (OSA). A LD driver IC that converts differential input LVPECL logic signals into an analog laser driving current drives the laser. The photodiode

is connected to a circuit providing post-amplification, quantization, and optical signal detection.

Signal Detect indicates the receiving of a good optical signal. This is a single-ended LVPECL output. When the input optical power decreases, Signal Detect will change from high state to low state at a level (de-assert point) below the sensitivity. As the input optical power increases, Signal Detect will change back from low state to high state at assert point. The assert level is at least 1.0 dBm higher than the de-assert level.

Block Diagram of The Transceiver

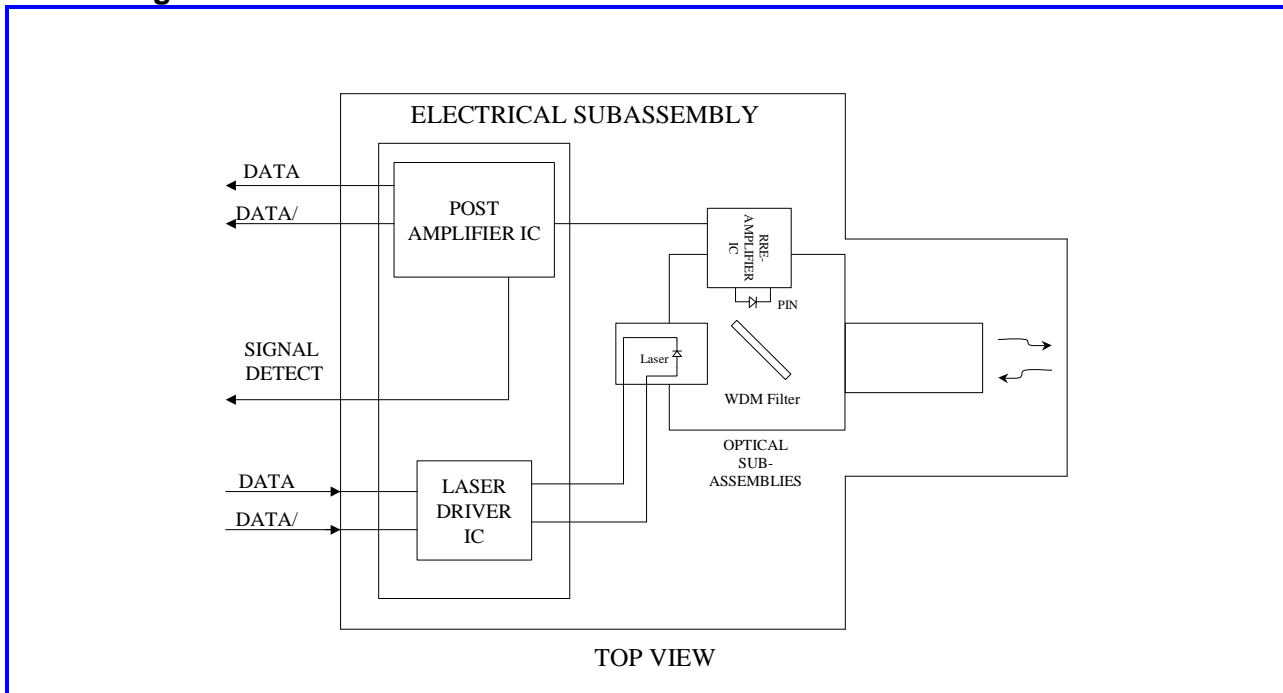

Specifications Subject to Change

11/2008



155 Mbps Bi-directional Multimode 1x9 Transceiver PTR155-B35/B53-M

Ordering Information

PART NUMBER	TX	RX	VOLTAGE	TEMPERATURE
PTR155-B35-M1	1310 nm	1550 nm	3.3 V	0 °C to 70 °C
PTR155-B35-M2	1310 nm	1550 nm	3.3 V	-40 °C to 85 °C
PTR155-B53-M1	1550 nm	1310 nm	3.3 V	0 °C to 70 °C
PTR155-B53-M2	1550 nm	1310 nm	3.3 V	-40 °C to 85 °C

Absolute Maximum Ratings

Parameter	Symbol	Min.	Max.	Units	Note
Storage Temperature	T_s	-40	85	°C	
Supply Voltage	V_{CC}	-0.5	4.0	V	
Input Voltage	V_{IN}	-0.5	V_{CC}	V	
Output Current	I_o	---	50	mA	
Operating Current	I_{OP}	---	400	mA	
Soldering Temperature	T_{SOLD}	---	260	°C	10 seconds on leads

Recommended Operating Conditions

Parameter	Symbol	Min.	Max.	Units	Note
Case Operating Temperature	T_c	0	70	°C	-M1 models
		-40	85		-M2 models
Supply Voltage	V_{CC}	3.1	3.5	V	
Supply Current	$I_{TX} + I_{RX}$	---	180	mA	

Transmitter Electro-optical Characteristics

$V_{CC} = 4.75 \text{ V to } 5.25 \text{ V}, T_A = 0 \text{ °C to } 70 \text{ °C (-40 °C to } 85 \text{ °C)}$

Parameter	Symbol	Min.	Typ.	Max.	Units	Note
Data Rate	B	50	155	200	Mb/s	
Output Optical Power 9/125 μm fiber	P_{out}	-8	---	0	dBm	Average
Extinction Ratio	ER	9	---	---	dB	
Center Wavelength (-B53) (-B35)	λ_c	1480	1550	1580	nm	
		1260	1310	1360		
Spectral Width (RMS)	$\Delta\lambda$	---	---	7	nm	
Rise/Fall Time, 10%~90%	T_{Rf}	---	1	2	ns	
Output Eye	Compliant with Telcordia GR-253-CORE Issue 3 and ITU-T recommendation G-957					
Data Input Voltage-High	$V_{IH} - V_{CC}$	-1.1	---	-0.74	V	Note 1
Data Input Voltage-Low	$V_{IL} - V_{CC}$	-2.0	---	-1.58	V	Note 1
Data Input Differential Voltage	V_{DIFF}	0.3	---	1.6	V	Note 1

Note 1: These inputs are compatible with 10K, 10KH and 100K ECL and PECL input.



155 Mbps Bi-directional Multimode 1x9 Transceiver PTR155-B35/B53-M

Receiver Electro-optical Characteristics

$V_{CC} = 4.75 \text{ V to } 5.25 \text{ V}$, $T_A = 0^\circ \text{ C to } 70^\circ \text{ C}$ (-40°C to 85°C)

Parameter	Symbol	Min.	Typ.	Max.	Units	Note
Data Rate	B	50	155	200	Mb/s	
Optical Input Power-maximum	P_{IN}	0	---	---	dBm	Note 1
Optical Input Power-minimum (Sensitivity)	P_{IN}	---	---	-28	dBm	Note 1
Operating Wavelength (-B53)	λ_c	1260	---	1360	nm	
(-B35)		1480	---	1600		
Return Loss	RL	---	---	-14	dB	$\lambda=1260\sim1360\text{nm}$ $\lambda=1400\sim1600\text{nm}$
Signal Detect-Asserted	P_A	---	---	-31	dBm	Average
Signal Detect-De-asserted	P_D	-45	---	---	dBm	Average
Signal Detect-Hysteresis	$P_A - P_D$	1.0	---	---	dB	
Signal Detect Output voltage - High	$V_{OH} - V_{CC}$	-1.1	---	-0.74	V	Note 2
Signal Detect Output voltage - Low	$V_{OL} - V_{CC}$	-2.0	---	-1.58	V	Note 2
Crosstalk	CRT	---	---	-45	dB	
Data Output Rise, Fall Time	$T_{r,f}$	---	1	2	ns	
Data Output Voltage-High	$V_{OH} - V_{CC}$	-1.1	---	-0.74	V	Note 2
Data Output Voltage-Low	$V_{OL} - V_{CC}$	-2.0	---	-1.58	V	Note 2

Note 1: The input data is at 155.52 Mbps, $2^{23} - 1$ PRBS data pattern with 72 "1"s and 72 "0"s inserted per the ITU-T recommendation G.958 Appendix 1. The receiver is guaranteed to provide output data with Bit Error Rate (BER) better than or equal to 1×10^{-10} .

Note 2: These outputs are compatible with 10K, 10KH and 100K ECL and PECL input.



155 Mbps Bi-directional Multimode 1x9 Transceiver PTR155-B35/B53-M

Connection Diagram

Pin-Out

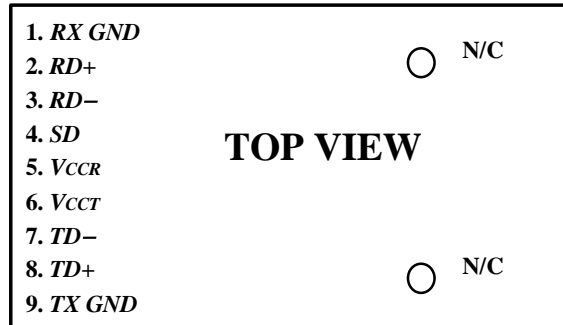

Pin	Symbol	Description
1	<i>RX GND</i>	Receiver Signal Ground This pin should be connected directly to the receiving ground plane
2	<i>RD+</i>	<i>RD+</i> is an open-emitter output signal. This high-speed differential LVPECL output should be terminated with standard PECL termination close the input pin of the next-stage device. (See recommended connection diagram)
3	<i>RD-</i>	<i>RD-</i> is an open-emitter output signal. This high-speed differential LVPECL output should be terminated with standard PECL termination close the input pin of the next-stage device. (See recommended connection diagram)
4	<i>SD</i>	Signal Detect. <i>SD</i> outputs a logic "1" (asserted) when optical input is above the asserted levels, and a logic "0" (de-asserted) when the optical input is below the de-assert level. <i>SD</i> can be terminated with 50 Ω to $V_{CCR} - 2 V$, or with a 510 Ω resistor to the <i>RX GND</i> to conserve electrical power with a minor compromise to signal quality. If Signal Detect output is not used, it can be left open. This Signal Detect output can be used to drive a PECL input.
5	V_{CCR}	Receiver Power Supply This pin should be connected to +3.3 Vdc with proper filtering closely located.
6	V_{CCT}	Transmitter Power Supply This pin should be connected to +3.3 Vdc with proper filtering closely located.
7	<i>TD-</i>	Transmitter Data In-Bar This high-speed differential LVPECL input should be terminated with standard PECL termination close the pin. (See recommended connection diagram)
8	<i>TD+</i>	Transmitter Data In This high-speed differential LVPECL input should be terminated with standard PECL termination close the pin. (See recommended connection diagram)
9	<i>TX GND</i>	Transmitter Signal Ground This pin should be connected directly to the transmitting ground plane



155 Mbps Bi-directional Multimode 1x9 Transceiver PTR155-B35/B53-M

Recommended Connections

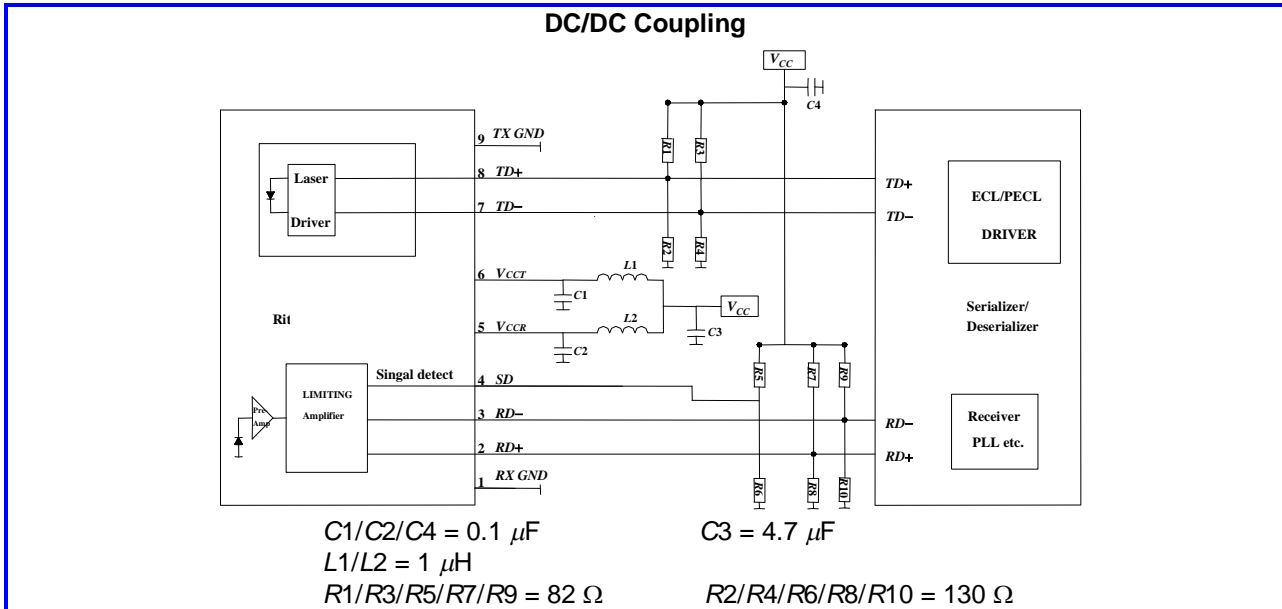

A connection circuit is recommended in the above diagram. The following guidelines are also recommended for designing the interface circuit:

- (1) The differential data lines should be treated as 50 Ω Micro strip or strip line transmission lines. This will help to minimize the parasitic inductance and capacitance effects. Locate termination at the received signal end of the transmission line. The length of these lines should be kept short and of equal length.
- (2) For the high speed signal lines, differential signals should be used, not single-ended signals, and these differential signals need to be loaded symmetrically to prevent unbalanced currents which will cause distortion in the signal.
- (3) Multi layer plane PCB is best for distribution of V_{CC} , returning ground currents, forming transmission lines and shielding, Also, it is important to suppress noise from influencing the fiber-optic transceiver performance, especially the receiver circuit.
- (4) A separate proper power supply filter circuits shown in Figure for the transmitter and receiver sections. These filter circuits suppress V_{CC} noise over a broad frequency range. this prevents receiver sensitivity degradation due to V_{CC} noise.
- (5) Surface-mount components are recommended. Ceramic bypass capacitors should be used for the 0.1 μF capacitors and a surface-mount coil inductor for 1 μH inductor. Ferrite beads can be used to replace the coil inductors when using quieter V_{CC} supplies, but a coil inductor is recommended over a ferrite bead. All power supply components need to be placed physically next to the V_{CC} pins of the receiver and transmitter.
- (6) A good, uniform ground plane with a minimum number of holes should be used to provide a low-inductance ground current return for the power supply currents.



155 Mbps Bi-directional Multimode 1x9 Transceiver PTR155-B35/B53-M

Dimensions

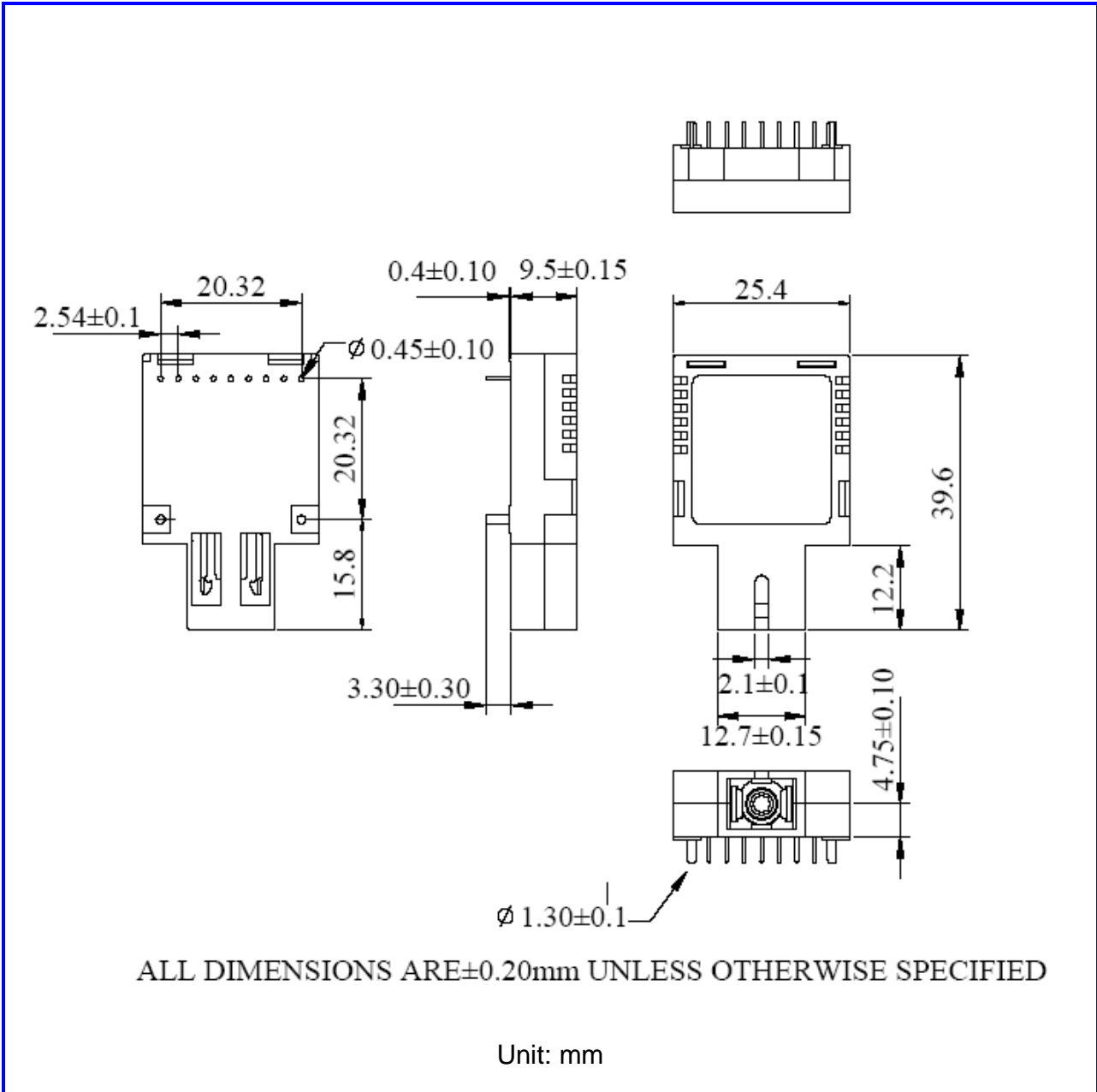



155 Mbps Bi-directional Multimode 1x9 Transceiver PTR155-B35/B53-M

Recommended Board Layout

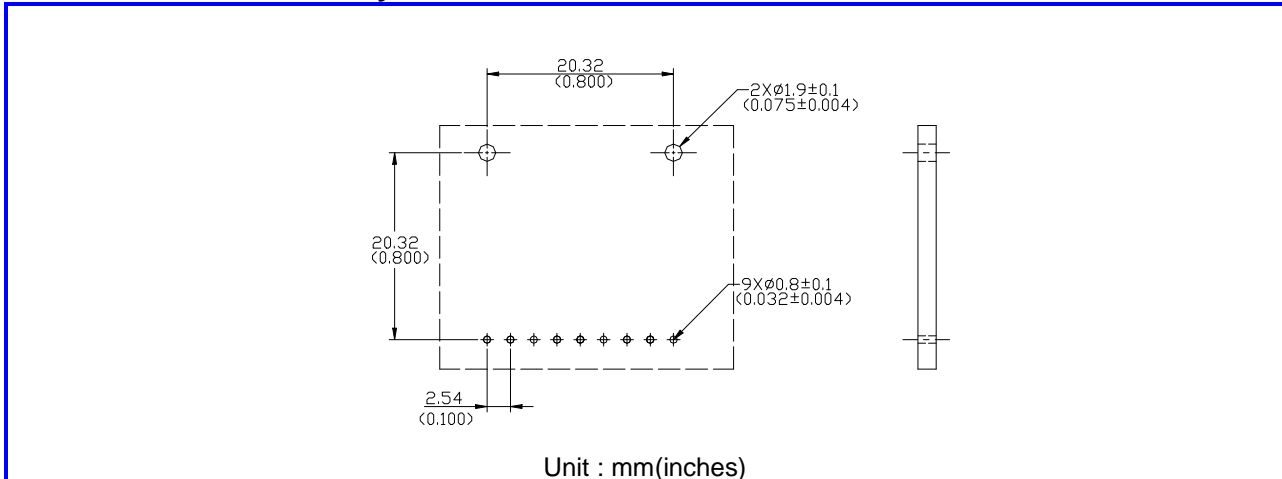

This transceiver is compatible with industry standard wave or hand solder processes. After wash process, all moisture must be completely removed from the module. The transceiver is supplied with a process plug to prevent contamination during wave solder and aqueous rinse as well as during handling, shipping or storage.

Solder fluxes should be water-soluble, organic solder fluxes. Cleaning and degreasing chemicals recommended for these transceivers are alcohol-based (methyl, isopropyl, isobutyl), aliphatic-based (hexane, heptanes) and other chemicals, such as soap solution or naphtha. Do not use partially halogenated hydrocarbons for cleaning/degreasing.