



# MM & SM 1X9 Dual ST Transceiver 155MBs 5V PTRX155ST-2



PD-LD Inc. offers laser based fiber optic transceiver modules in convenient industry standard 1X9 style packages that are optimized for operation with both MM and SM optical fiber. The PTRX series modules are designed to operate at 155MBs over both 9/125um singlemode and 50/125um multimode optical fiber.

The transmitter section is built using 1310nm FP laser diodes and an IC driver that converts PECL signals into an optical output stream. The driver circuit maintains operation of the laser diode over an industrial operating temperature range of -40 to 85°C. The output of the laser diode is regulated such that they meet the Class 1 Eye Safety standards as outlined by the ITU documents EN 60825-1.

The receiver section is built using a high sensitivity InGaAs PIN photodiode that converts incoming optical light into a current output. This output is then fed to a transimpedance amplifier and post amplifier which produces PECL data. The pre-amp circuit contains an automatic gain control ( AGC) feature that permits operation with high optical input power (0dBm) without saturating.

These modules are designed for operation with a single +5V power supply.

### Features

- **Operating at 155MBs**
- **14 dB Minimum Link Budget over SMF**
- **20 dB Minimum Link Budget over MMF**
- **ST Duplex Connector Interface**
- **Single 5.0V Power Supply**
- **Industry Standard 1X9 Footprint**
- **Differential LVPECL inputs and outputs**
- **Class 1 Eye Safe Laser Product ( EN 60825-1)**
- **Wave Solder Process Compatible**

### Applications

- **Fiber optic communications systems**
- **Networking Digital and Analog Signal transmission**

### Absolute Maximum Ratings

Parameter	Symbol	Min	Max	Units
Storage Temperature	Ts	-40	85	°C
Supply Voltage	Vcc	-0.5	6.0	V
Input Voltage	Vin	-0.5	Vcc	V
Output Current	Io	—	50	mA
Operating Current	Iop	—	400	mA
Soldering Temperature	Tsold		260	°C for 10 sec on leads

<sup>1</sup>Examples only; most device/packaging combinations available.

Changes to specifications may be made without notice.

4-09 PLD-TRX Rev.B



Ordering Information					
Part Number	Input/Output	Signal Detect	Voltage	Temperature	ST Receptacle
PTRX155ST-2	DC/DC	LVPECL	5.0V	-40°C to 85°C	Metal

Operating Environment					
Parameter	Symbol	Min.	Max.	Unit	Note
Case Operating Temperature	Tc	-40	85	°C	
Supply Voltage	Vcc	4.75	5.25	V	

Transmitter Electro-Optical Characteristics Vcc=4.75 to 5.25V, Tc=-40 to 85°C						
Parameter	Symbol	Min.	Typ.	Max.	Unit	Note
Data Rate	B	50	155	200	Mb/s	
Output Optical Power 9/125 um fiber	Pout	-20	—	-11	dBm	Average
Output Optical Power 50/125 um fiber	Pout	-12	—	-4	dBm	Average
Extinction Ratio	ER	8.2	—	—	dB	
Center Wavelength	Lambda C	1261	1310	1360	nm	
Spectral Width (RMS)	Delta Lambda	—	—	4	nm	
Rise/Fall Time (10~90%)	Trf	—	1	2	ns	
Output Eye	Compliant with Telcordia GR-253-CORE Issue 3 and ITU-T recommendation G-957					
Power Supply Current	Icc	—	—	140	mA	
Transmitter Data Input Voltage-High	V <sub>IH</sub> -Vcc	-1.1	—	-0.74	V	
Transmitter Data Input Voltage-Low	V <sub>IL</sub> -Vcc	-2.0	—	-1.58	V	



<b>Receiver Electro-optical Characteristics</b> <b>V<sub>cc</sub>=4.75 to 5.25V, T<sub>c</sub>= -40 to 85°C</b>						
<b>Parameter</b>	<b>Symbol</b>	<b>Min.</b>	<b>Typ.</b>	<b>Max.</b>	<b>Unit</b>	<b>Note</b>
<b>Data Rate</b>	B	50	155	200	Mb/s	
<b>Optical Input Power Max</b>	P <sub>in</sub>	0	—	—	dBm	Note 1
<b>Optical Input Power Min</b> (Sensitivity , 9/125 um fiber )	P <sub>in</sub>	—	—	-34	dBm	Note 1
<b>Optical Input Power Minimum</b> ( Sensitivity , 50/125 um fiber )	P <sub>in</sub>	—	—	-32	dBm	Note 1
<b>Operating Wavelength</b>	Lambda	1260	—	1610	nm	
<b>Signal Detect Asserted</b>	P <sub>a</sub>	—	—	-32	dBm	Average
<b>Signal Detect DeAsserted</b>	P <sub>d</sub>	-45	—	—	dBm	Average
<b>Signal Detect Hysteresis</b>	P <sub>a</sub> -P <sub>d</sub>	1.0	—	—	dB	
<b>Signal Detect Output Voltage-High</b>	V <sub>OH</sub> -V <sub>cc</sub>	-1.1	—	-0.74	V	Note 2
<b>Signal Detect Output Voltage-Low</b>	V <sub>OL</sub> -V <sub>cc</sub>	-2.0	—	-1.58	V	Note 2
<b>Power Supply Current</b>	I <sub>cc</sub>	—	—	140	mA	Note 3
<b>Data Output Voltage High</b>	V <sub>OH</sub> -V <sub>cc</sub>	-1.1	—	-0.74	V	Note 2
<b>Data Output Voltage Low</b>	V <sub>OL</sub> -V <sub>cc</sub>	-2.0	—	-1.58	V	Note 2

Note 1: The input data is at 155.52Mbps 2<sup>23</sup>-1 PRBS data pattern. The receiver is guaranteed to provide output data with Bit Error rate (BER) better than or equal to 1 X 10<sup>-10</sup>.

Note 2: These outputs are compatible with 10K, 10KH and 100K ECL and PECL input.

Note 3: The current exclude the output load current.



Block Diagram of Transceiver

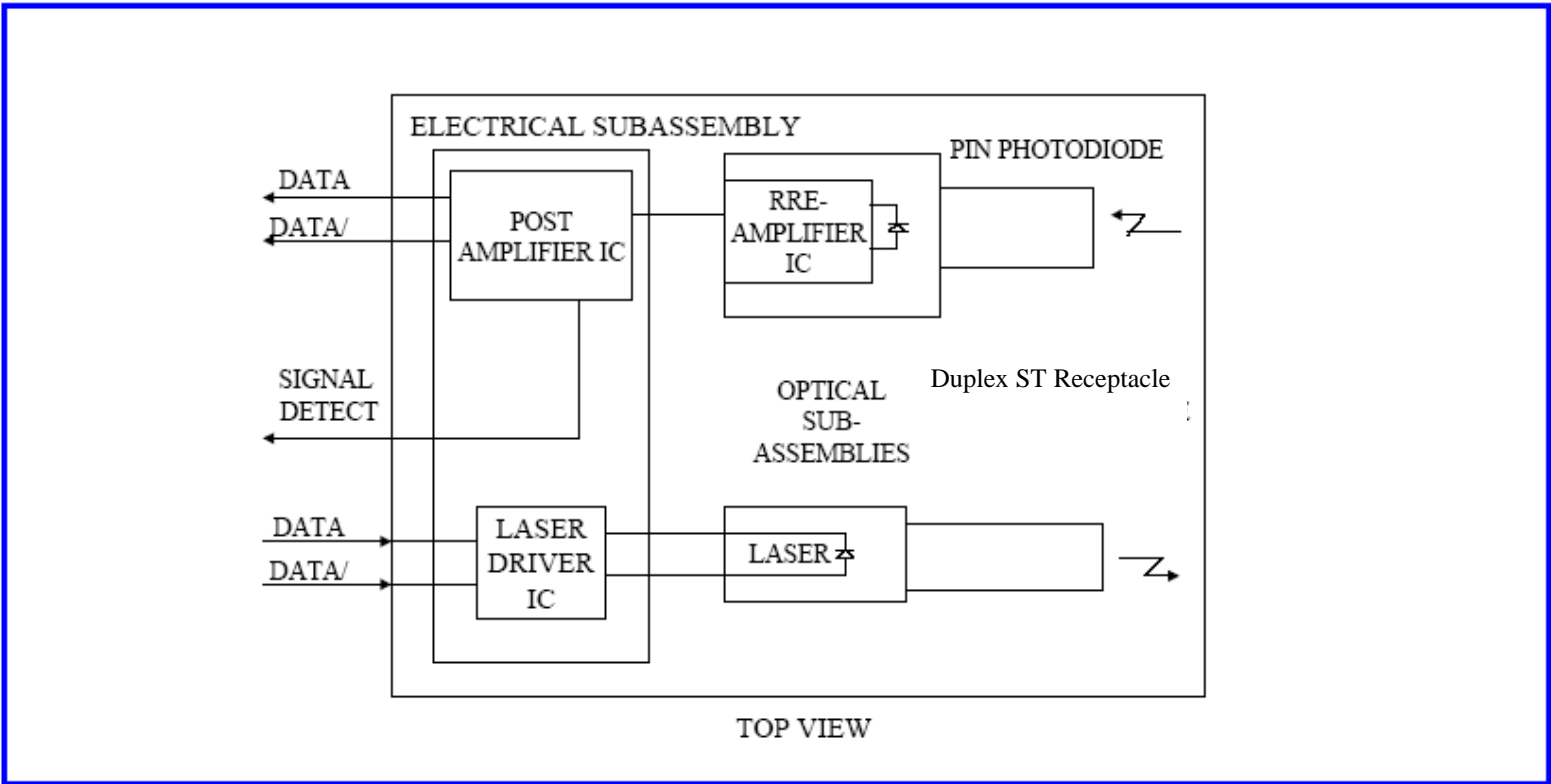

PIN-Out and Connection Diagram

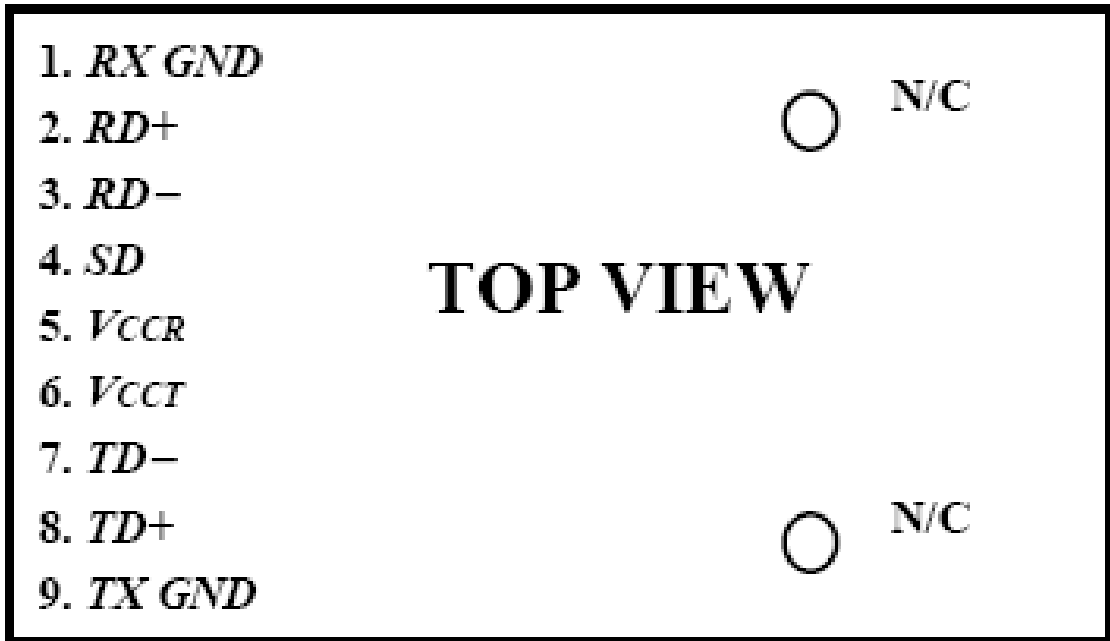

## Recommended Circuit Schematic

### DC/DC Coupling

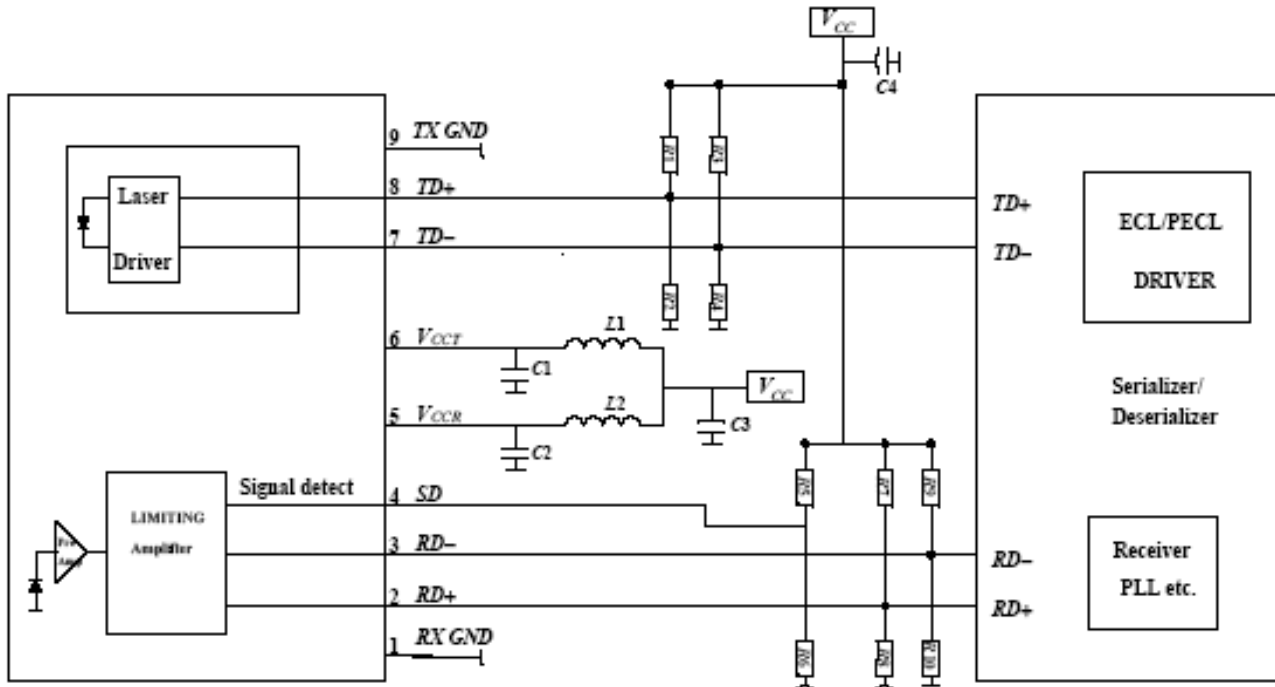

$$C1/C2/C4 = 0.1 \mu\text{F}$$

$$L1/L2 = 1 \mu\text{H}$$

$$R1/R3/R5/R7/R9 = 82 \Omega$$

$$C3 = 4.7 \mu\text{F}$$

$$R2/R4/R6/R8/R10 = 130 \Omega$$

## Recommended Board Layout Hole pattern

