



Standard-Area Silicon Avalanche Photodiodes (230, 500 μm)

PD-LD Inc. offers 2 sizes of standard Silicon Avalanche Photodiodes in several styles of fiber coupled packages. The semiconductors are available in two standard sizes: 230 micron or 500 micron active areas. Our Silicon APDs cover the optical spectrum from 550 nm to 1050 nm and are optimized for peak performance in the 880nm to 905nm region. These devices are available in fiber pigtailed co-axial packages or in connector style receptacle packages.



Manufacturing

Efficient package designs and manufacturing processes allow PD-LD to rapidly support both small and large volume requirements. Complete 100% testing of all critical parametric device values ensure optimal performance and quality. Not all receptacle packaging styles are represented on this data sheet, so please contact PD-LD for specific needs.

Features

- 230 & 500 micron areas
- 500-1015nm Optical Spectrum

Performance Specifications: Examples (more options available)

Electrical Characteristics								
Parameter	PDSAB Series				PDSAD Series			
	Min	Typ	Max	Units	Min	Typ	Max	Units
Diameter		230		μm		500		μm
Breakdown Voltage @ $I_d=10 \mu\text{A}$	150	230	300	Volt	150	230	300	Volt
Responsivity @ 880nm & M=100	45	50		A/W	45	50		A/W
V_{br} Temperature Coefficient		0.6	1.5	$V/^{\circ}\text{C}$		0.6	1.5	$V/^{\circ}\text{C}$
Dark Current @ M=100		1.0	3.0	nA		1.5	5.0	nA
Noise Current @ M=100		0.2	0.5	$\text{pA}/\sqrt{\text{Hz}}$		0.2	0.5	$\text{pA}/\sqrt{\text{Hz}}$
Capacitance @ M=100		1.0	1.5	pF		2.0	3.0	pF
Rise Time @ M=100		500		psec		500		psec



Standard-Area Silicon Avalanche Photodiodes (230, 500 μm)

Pinout Drawings

Packaging Options

Pigtailing

Devices can be pigtailed with any size optical fiber that is compatible with its active area size. Pigtails may range in core size from 3 micron to 200 micron. One meter is the standard length, but any length or connector termination may be specified. Pigtails may be terminated with ST, FC, SC and LC connectors with either PC or APC polish.

Receptacles

Standard ST, FC and SC housings are available in both panel and board mountable versions. These receptacles can be optimized for use with both single mode and multimode optical fibers.

Pin#1: GND
Pin#2: Anode
Pin#3: Cathode

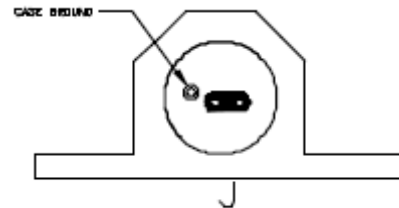
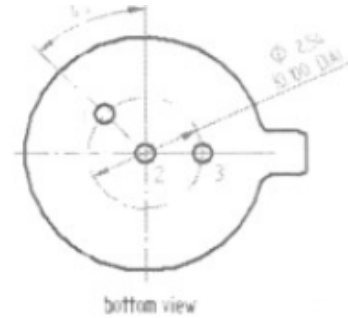

Mechanical Drawing for
PDSAB2302FCD-J-0-01
PDSAD5002FCD-J-0-01

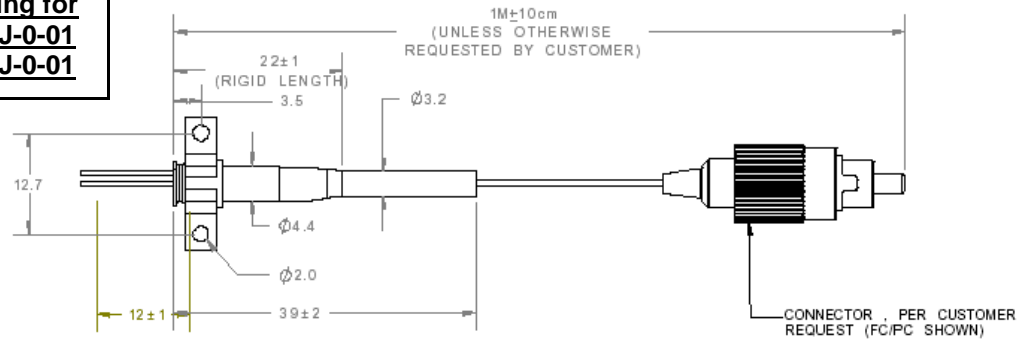

NOTES:

- 1 THESE DEVICES ARE ESD SENSITIVE. ESD PRECAUTIONS ARE ADVISED.
- 2 ALL DEVICES ARE SHIPPED WITH ESD LEAD PROTECTORS AND DUST COVERS.
- 3 ALL DEVICES WILL BE MARKED WITH A PD-LD SERIAL NUMBER.

▲ BRASS, NICKEL PLATED

▲ SS303

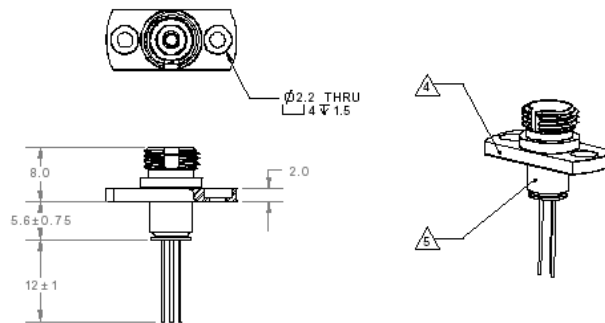

Mechanical Drawing for
PDSAB230FC13-W-0
PDSAD500FC13-W-0

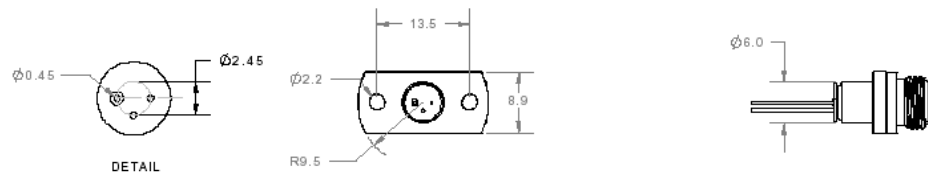



Standard-Area Silicon Avalanche Photodiodes (230, 500 μm)

Ordering Information

Data Legend: Pigtailed Silicon APDs

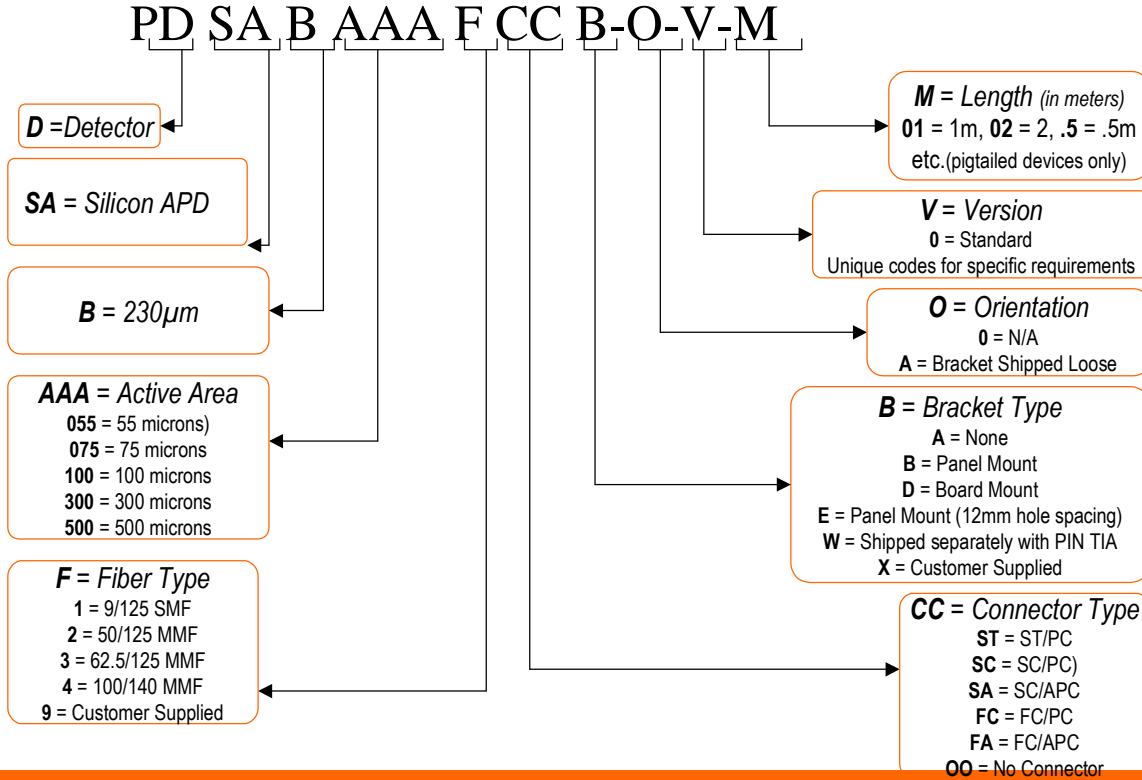

Data Legend: Receptacle Silicon APDs

