

SPC – PSD

High Linearity Position Sensing Detector with Signal Processing Circuit

Part number: S1 – 0257

Description: 1L2,5_SU74_SPC01

The SiTek 1L2,5_SU74_SPC01 is a 1L2,5 PSD with an attached signal processing circuit. The PSD currents are output as bipolar voltages representing the position and intensity of the centroid of a light spot on the PSD. The intensity signal can be used for external normalisation of the position (difference) signal in regard to light intensity dependence. Inputs are available for external adjustment of offset voltages.

In order to obtain maximum precision, high reliability and small size the SPC01 is built using thick film technology and laser trimmed resistors on a 20,5 x 20,5 mm² ceramic substrate. The SPC01 is delivered with surface mount leads.

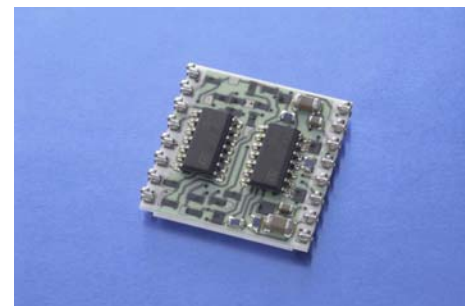
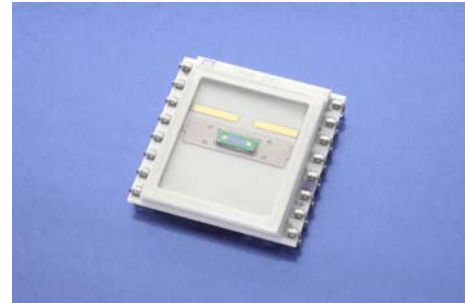

Electrical specification

Parameter	Symbol	Min.	Typ.	Max.	Unit
Active area			2,5 x 0,6		mm ²
Position non-linearity			0,1	0,2	% (±)
Reverse bias	V _r		15		V
Dark current of PSD @ V _r	I _d		2	10	nA
Responsivity	r		63		V/mW
Transimpedance	R _f	0,999*10 ⁵	1,000*10 ⁵	1,001*10 ⁵	V/A
Amplification in sum and difference stages	A _v	0,999	1	1,001	
Output voltage	V _{out}			± 12	V
Output noise	V _{noise}		3		mVp-p
Bandwidth	f _{3dB}		400		kHz
Slew rate	SR	8	13		V/μs
Supply current			12	23	mA

Absolute maximum ratings

Parameter	Symbol	Value	Unit
Power supply voltage	V _s	± 18	V
Output short-circuit time		Continuous	
Operating temperature	T _{oper}	70	°C
Storage temperature	T _{stg}	100	°C

Test conditions: Room temperature 23 °C, Power supply voltage ± 15 V, Light source wavelength 940 nm. Position non-linearity are valid within 80 % of the detector length.

Package: 16 pin ceramic substrate, 20,5 x 20,5 mm², with protective window.

For further information about PSD specific parameters see specification for S1-0001 1L2,5_CP2.

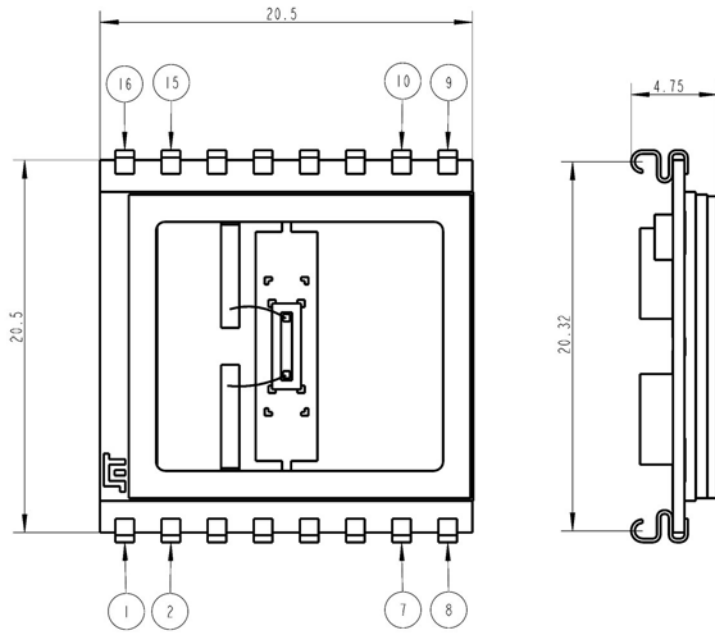

Pin no.	Input/Output
1	Amp Y1
2	N.A.
3	N.A.
4	Sum Y
5	N.A.
6	OA Sum Y
7	N.A.
8	N.A.
9	N.A.
10	+15 V
11	Gnd
12	Gnd
13	Diff Y
14	OA Diff Y
15	-15 V
16	Amp Y2

Please note that all pins not applicable (N.A.) for 1-dimensional devices must be left floating.

Block schematics

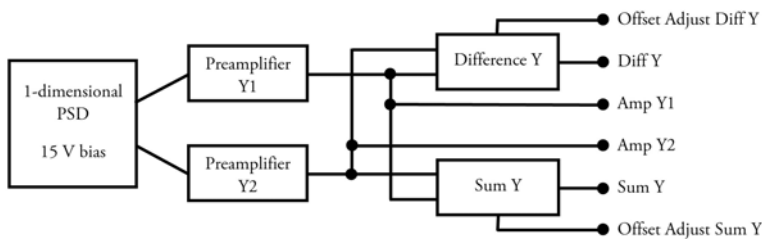

Features

- Analogue outputs of all sum and differential signals
- Laser trimmed resistors
- Inputs for external adjustment of offset voltages
- Good thermal tracking
- Small size

Applications

- Analogue PSD front-end in displacement measuring systems for OEM as well as evaluation purposes.

Application Information

Inputs 6 and 14 are used for external offset compensating voltages. Such a voltage can, as shown in the figure, be derived from a voltage divider and connected to the SPC input through a suitable series resistor.

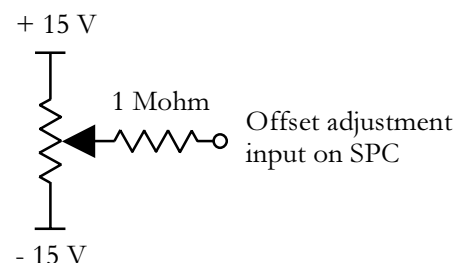

Information in this data sheet is believed to be reliable. However, no responsibility is assumed for possible inaccuracies or omissions. Specifications are subjected to changes without notice.

SiTek
ELECTRO OPTICS