

Fiber Coupler Instruction Manual

1. Introduction

1.1 General Information

A fiber coupler is used to couple collimated laser beams into an optical fiber. Using adjustable screws, the optics inside the fiber coupler can be positioned so as to focus the laser light exactly into the fiber tip to couple the maximum amount of power possible.

1.2 Technical Data

The fiber coupler is designed for a wavelength range of 400 nm to 1300 nm and an optical output of up to a maximum of 150 W. Laser beams with a maximum diameter of 10 mm can be coupled into optical fibers with a core diameter of 100 μm to 2000 μm . The NA of the fiber must be >0.22 .

The optics inside the fiber coupler are equipped with an AR coating (coating A: 400 nm to 700 nm, coating B: 633 nm to 1064 nm, coating C: 800 nm to 1300 nm), see Figures 1-3 on page 2. The fiber connection is an SMA connection. Other connections are available upon request.



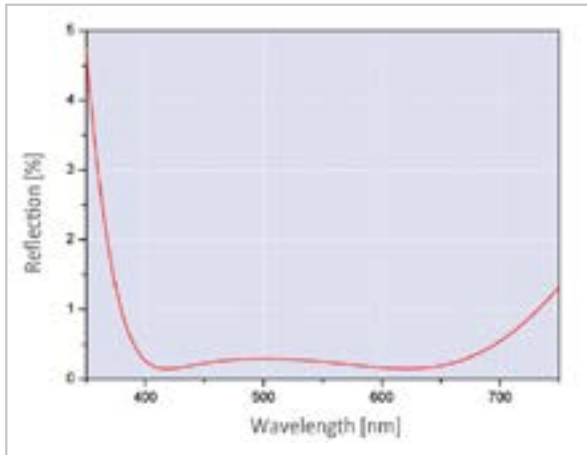

Figure 1: AR coating A: 400 nm to 700 nm

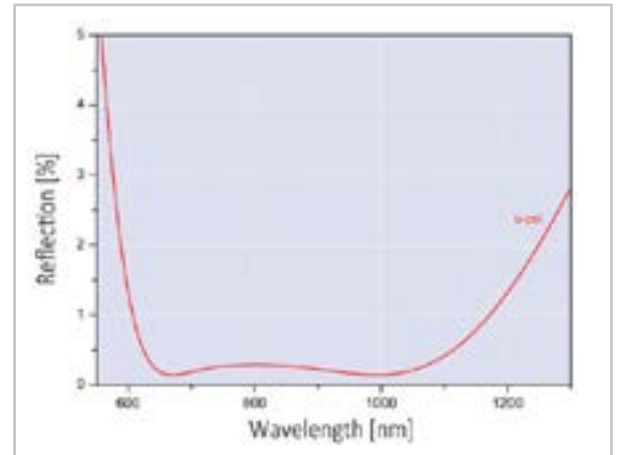

Figure 2: AR coating B: 633 nm to 1064 nm

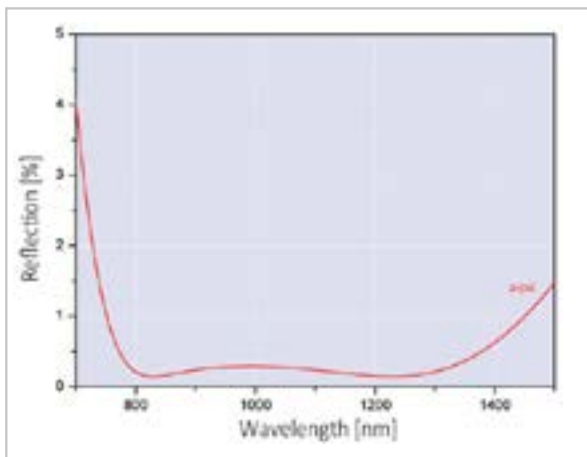

Figure 3: AR coating C: 800 nm to 1300 nm

2. Applications

2.1 Intended Use

A fiber coupler is used with a laser and, therefore, must always only be handled by technically experienced and specially trained personnel. This applies in particular to the assembly and disassembly of a fiber coupler in the laser.

2.2 Use other than as Intended

This includes all applications not intended for use as described in item 2.1. In particular, all dangerous actions related to the use of laser radiation are strictly prohibited. All damages incurred during the course of any prohibited application will not be subject to liability by the manufacturer.

3. Standards and Regulations

DIN EN 60825-1: 2008 Safety of Laser Products

DIN EN 62079 Preparation of Instructions – Structuring, Content, and Presentation

4. Safety Instructions

The safe handling of this unit in accordance with regulations is the responsibility of the user.

5. Fiber Coupler Assembly and Functionality

The input aperture is on the underside of the fiber coupler. Two lateral adjustment screws are used to position the optics along the x-axis and y-axis so that the laser beam meets the fiber tip. A third lateral adjustment screw is used to lock the optics in place inside the fiber coupler. With the help of three screws on the top of the housing, the optics can be tilted by up to 5°. The z position (distance of the optics to the fiber tip) is adjusted using a knurled wheel and a locking ring, ultimately shifting the fiber tip relative to the optics.

To adjust the fiber coupler for the first time, the optics along the x-axis and y-axis should be positioned so that the lens is in the center. With the knurled wheel, the fiber connection is shifted upwards completely in order to screw on the fiber. Afterwards, the fiber tip is shifted down using the knurled wheel until it yields maximum coupling. Subsequently, the optics have to be adjusted along the x-axis and y-axis to achieve a maximum coupling. In small fiber diameters, the lens can also be tilted using the three screws on top of the fiber coupler to achieve a maximum coupling.



Figure 4: Fiber coupler assembly and functionality

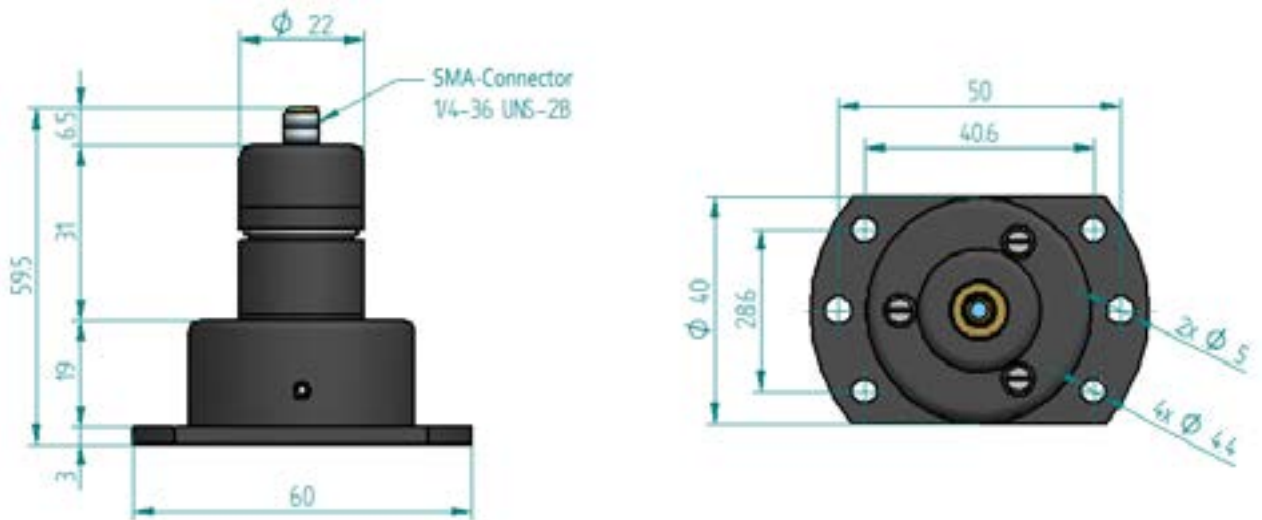

Figure 5: Dimensions of fiber coupler

6. Maintenance and Repairs

The fiber coupler is maintenance free. The optics on the inside of the fiber coupler are sensitive and must always be kept clean. Dust detected on the lens should only be removed by blowing it off with dry air. The use of liquid cleansing agents or solutions can cause irreparable damage to the optics.

7. Disposal

After use, this unit may be disposed of with household waste.

8. Warranty

The warranty expires 12 months after delivery. Repairs made to the unit by any person other than the manufacturer will void the warranty. The terms and conditions of the warranty can be found in Laser Components GmbH's General Terms and Conditions at www.lasercomponents.com.