



PDB-C107

Silicon Photodiode

The PDB-C107 is a 17.9mm² silicon photodiode designed for applications requiring a large active area photodiode with low capacitance and high-speed response time. The device is packaged on a 2-pin ceramic with clear glob top epoxy.

Applications

Industrial

Instrumentation

Medical

Features

Low Noise, High Shunt Resistance

Visible-NIR Sensitive

Large Active Area

High Speed Response Time

2-pin Ceramic

PASSION FOR PHOTONICS
 DS PDB-C107 Rev. A

Absolute Maximum Ratings

Parameter	Symbol	Min	Max	Unit
Reverse Voltage	V_R	-	75	V
Wavelength Range	-	350	1100	nm
Operating Temperature	T_{OP}	-40	+100	°C
Storage Temperature	T_{STG}	-55	+100	°C
Package	Ceramic			

Typical Electro-Optical Specifications at $T_A=23\text{ °C}$

Parameter	Test Conditions	Symbol	Min	Typ	Max	Unit
Short Circuit Current	$H=100\text{ fc}$, 2859 K	I_{SC}	150	-	-	μA
Dark Current	$V_R=5\text{ V}$	I_D	-	150	300	nA
Shunt Resistance	$V_R=10\text{ mV}$	R_{SH}	200	-	-	M Ω
Junction Capacitance	$V_R=10\text{ V}$; $f=1\text{ MHz}$	C_J	-	100	-	pF
Responsivity	$\lambda=900\text{ nm}$, $V_R=0\text{ V}$	-	0.55	0.60	-	A/W
Breakdown Voltage	$I=10\mu\text{A}$	V_{BD}	50	100	-	V
Noise Equivalent Power	$V_R=0\text{ V}$ @ $\lambda=\text{Peak}$	NEP	-	4×10^{-13}	-	W/ $\sqrt{\text{Hz}}$
Response Time	$R_L=50\text{ K}\Omega$, $V_R=0\text{ V}$	T_R	-	80	-	nS
	$R_L=50\text{ K}\Omega$, $V_R=10\text{ V}$	T_R	-	10	-	nS

Spectral Response

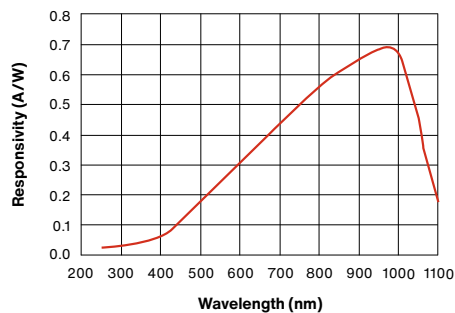

Mechanical Specifications

Units in inches [mm]

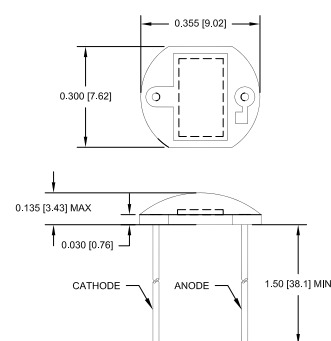
PASSION FOR PHOTONICS
 DS PDB-C107 Rev. A

Care and handling instructions

Your optoelectronic components are packaged and shipped in opaque, padded containers to avoid ambient light exposure and damage due to shock from dropping or jarring.

Care must be taken to avoid exposure to high ambient light levels, particularly from tungsten sources or sunlight.

- These components can be rendered inoperable if dropped or sharply jarred. The wire bonds are delicate and can become separated from the bonding pads when the component is dropped or otherwise receives a sharp physical blow.
- Most windows on photodiodes are either silicon or quartz. They should be cleaned with isopropyl alcohol and a soft (optical grade) pad.
- Photodiode exposure to extreme high or low storage temperatures can affect the subsequent performance. Maintain a non-condensing environment for optimum performance and lifetime.
- All devices are considered ESD sensitive. The photodiodes are shipped in ESD protective packaging. When unpacking and using these products, anti-ESD precautions should be observed.
- Photodiode packages and/or operation may be impaired if exposed to CHLOROETHENE, THINNER, ACETONE, TRICHLOROETHYLENE or any harsh chemicals.
- Optoelectronic components in plastic packages should be given special care. Clear plastic packages are more sensitive to environmental stress than those of black plastic. Storing devices in high humidity can present problems when soldering. Since the rapid heating during soldering stresses the wire bonds and can cause wire to bonding pad separation, it is recommended that devices in plastic packages to be baked for 24 hours at 85°C.
- The leads on the photodiode SHOULD NOT BE FORMED. If your application requires lead spacing modification, please contact Advanced Photonix Applications group at Techsupport@advancedphotonix.com before forming a product's leads. Product warranties could be voided.
- Most devices are provided with wire or pin leads for installation in circuit boards or sockets. Observe the soldering temperatures and conditions specified below:
 - Soldering Iron: Soldering 30 W or less
 - Temperature at tip of iron 300°C or lower.
 - Dip Soldering: Bath Temperature: 260±5°C.
 - Immersion Time: within 5 Sec.
 - Soldering Time: within 3 Sec.
 - Vapor Phase Soldering, Reflow Soldering: DO NOT USE

Legal Disclaimer

Information in this data sheet is believed to be correct and reliable. However, no responsibility is assumed for possible inaccuracies or omission. Specifications are subject to change without notice.



Most of our standard catalog products are RoHS Compliant. Please contact us for details.

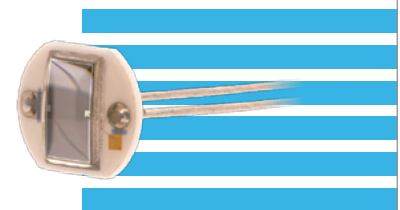

PASSION FOR PHOTONICS
DS PDB-C107 Rev. A