



High Power UV-C LED
S3535-H-DR350-270nm LED
Specifications

V1.6 March 2026

RISK GROUP 3

WARNING UV EMITTED FROM THIS PRODUCT
AVOID EYE AND SKIN EXPOSURE TO UNSHEILED PRODUCT

AVERTISSEMENT UV émis par ce produit. Éviter l'exposition des yeux et de la peau à un produit non protégé

ADVERTENCIA Emisión de rayos ultravioleta por este producto. Evite la exposición de los ojos y la piel al producto sin protección

警告 この製品から放出される紫外線。シールドされていない製品への目や皮膚の露出を避ける



CAUTION - RISK OF PERSONAL INJURY. THIS LED PACKAGE IS NOT INTENDED FOR GENERAL ILLUMINATION AND MAY REQUIRE THE USE OF SPECIAL SAFEGUARDS. INSTALL AND USE ONLY IN STRICT ACCORDANCE WITH THE PRODUCT AND PACKAGING MARKINGS

INTEGRATION OF THIS LED PACKAGE INTO LED LIGHT SOURCES (ARRAYS, LAMPS OR LUMINAIRES) OR ADDITION OF REFLECTIVE OR MAGNIFYING OPTICS MAY CHANGE THE EXPECTED PHOTOBIOLOGICAL SAFETY CHARACTERISTICS OF SUCH DEVICES. THE ASSIGNED RISK GROUP CLASSIFICATION OF THIS LED PACKAGE MAY NOT NECESSARILY INDICATE THE RISK GROUP CLASSIFICATION OF THE LED LIGHT SOURCE



S3535-H-DR350-265nm LEDs Specifications

1. Identification Convention

SMD type 3535 package

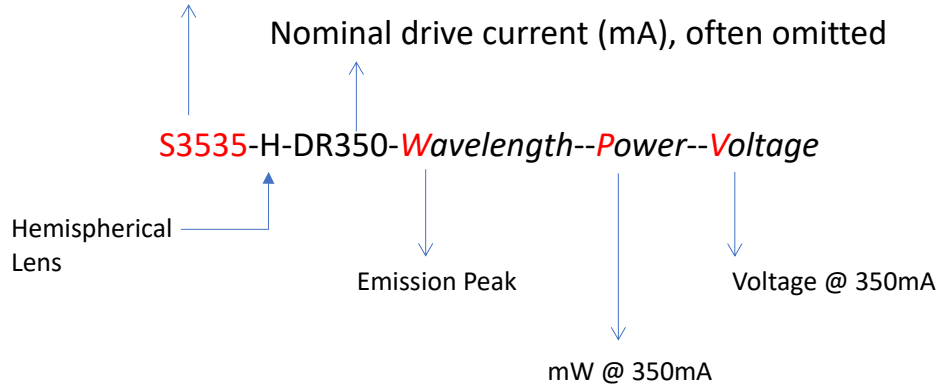

Example:

S3535-H-DR350-W270-P200-V6.5

Interpretation:

Surface Mount type 3.5 mm x 3.5 mm packaged LED with Hemispherical Lens

Nominal Drive Current = 350 mA

Peak wavelength = 270 (265-275 nm) for L0 bin

Power output @ 350mA = 200 mW for U3 bin

Forward voltage @ 350mA = 6.0-7.0 V for V2 bin

For binning, please refer to page 9

Product specifications subject to change without notice

S3535-H-DR350-270nm LEDs Specifications

2. S3535-H UVC LEDs package diagrams

All units in mm

External dimension tolerance: ± 0.1 mm

Internal dimension tolerance: ± 0.05 mm

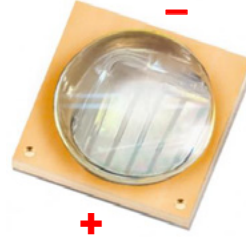

Top view

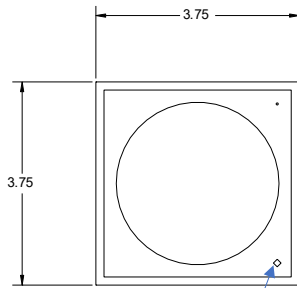

Front-side anode Marks

Bottom view

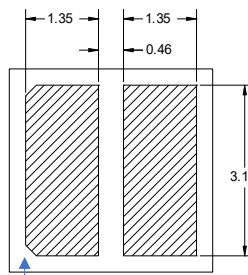

Back-side cathode mark

Side view

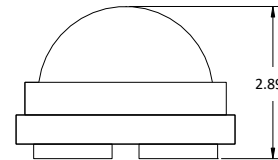

Recommended Solder Pattern on PCB

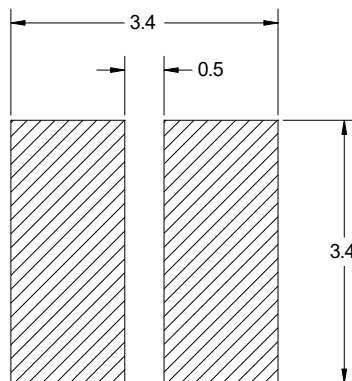

Electrical diagram of S3535-H

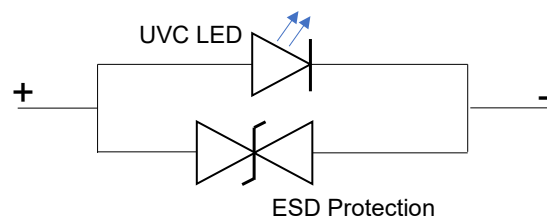

Special note: This product includes a Zener/TVS chip.

Specifications Subject to Change without notice

Hex-S3535-H-DR350-270nm LEDs

Hex 3535H drawing

All sizes in mm

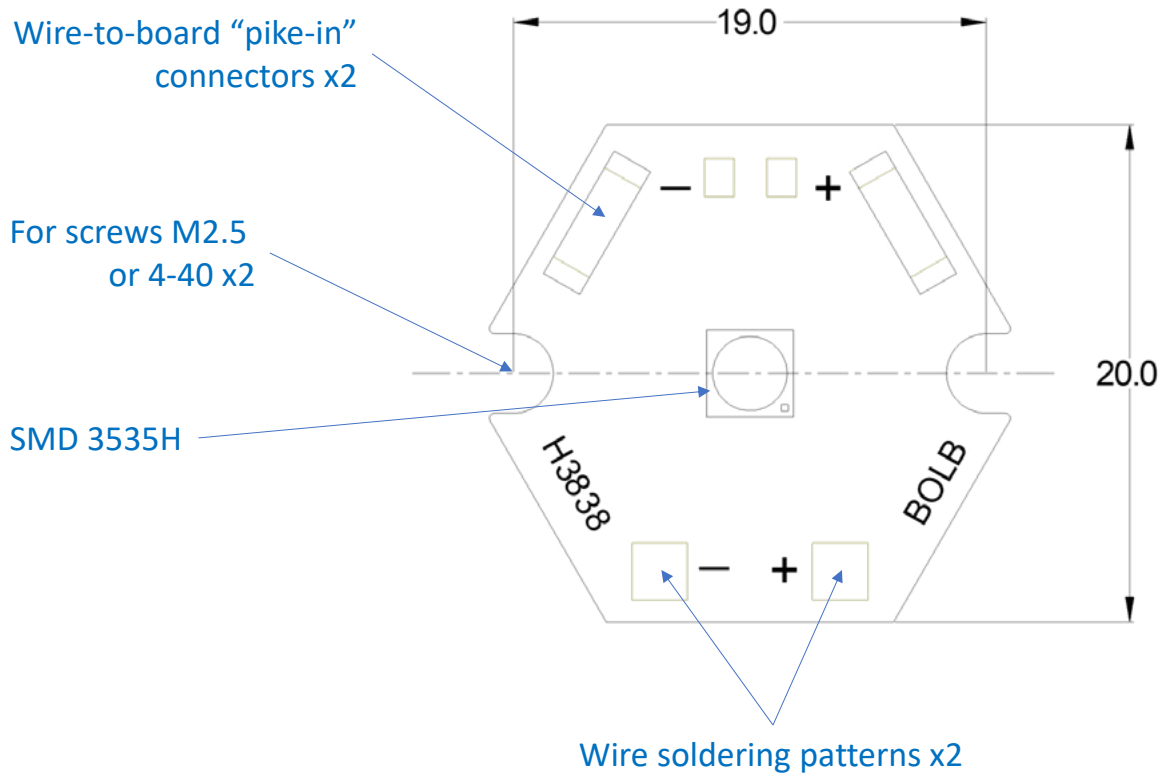

Note: For wire soldering to the Hex, we recommend using the Low-Temperature Lead-Free Solder #247, with a melting point of 137°C/278°F.

S3535-H-DR350-270nm LEDs Specifications

3. Absolute Maximum Ratings at Ta=25°C

Parameter	Symbol	Min	Typical	Max	Unit
Forward Current	I_F	-	350	500	mA
Power Dissipation	PD	-	2.28	3.75	W
Operating Temperature	T_{opr}	-10	<40	+60	°C
Storage Temperature	T_{stg}	-40	25	+100	°C
Junction Temperature	T_j	-	-	80	°C
Electrostatic Discharge	ESD	-	-	4000	V

4. Typical Optical Electrical Parameters at Ta=25°C^[7]

Parameter	Conditions	Symbol	Min.	Typ.	Max	Unit
Peak Wavelength ^[1]	I=350mA	λ_p	260	270	275	nm
Radiant Flux ^[2]		ϕ_e	130	150	180	mW
Forward Voltage ^[3]		V_F	5.5	6.5	7.5	V
Spectrum Half Width		$\Delta\lambda$	9	10	11	nm
View Angle ^[4]		$2\theta_{1/2}$	-	70 Avg.	-	°(degree)
Thermal Resistance Junction-Board ^[5,6]		$R_{th\ j-b}$	-	10	-	°C/W

Notes:

1. Peak Wavelength Tolerance ± 2 nm
2. Radiant Flux Measurement tolerance $\pm 10\%$
3. Forward Voltage Tolerance $\pm 3\%$
4. View angle Tolerance $\pm 10^\circ$
5. $R_{th\ j-b}$ is the thermal resistance from chip junction to bottom of MCPCB including thermal grease measured at 350mA
6. Reference for thermal resistance: Using 2.5mm x 2.5mm x 1.6 mm aluminum MCPCB
7. All measurements gathered under DC test conditions using suitably sized heat sink

S3535-H-DR350-270nm LEDs Specifications

5. Characteristic diagrams at Ta=25°C

Figure 1. Typical Current-Voltage Relationship

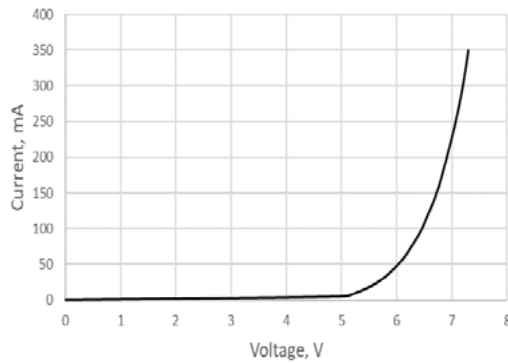

Figure 2. Relative radiant flux vs. forward current

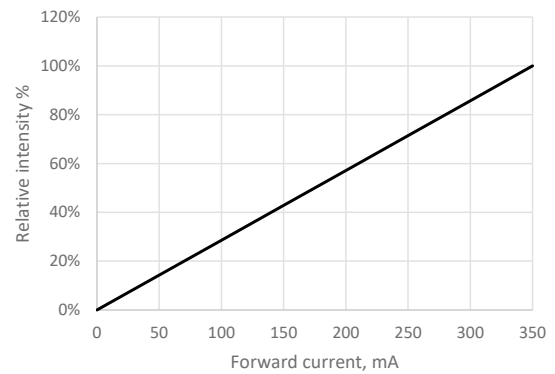

Figure 3. Peak wavelength vs. temperature

[Ta=25°C, I_F=350mA]

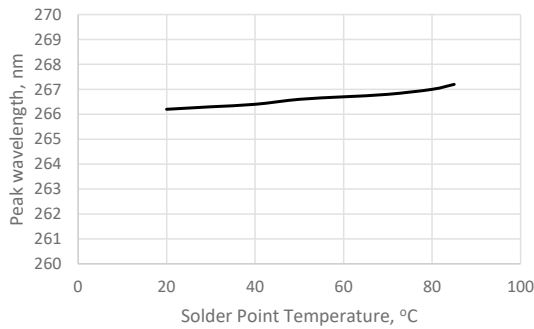

Figure 4. Typical spectrum

[Ta=25°C, I_F=350mA]

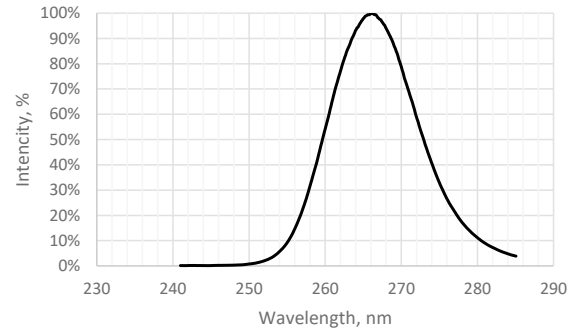

Figure 5. Voltage vs. solder point temperature

[Ta=25°C, I_F=350mA]

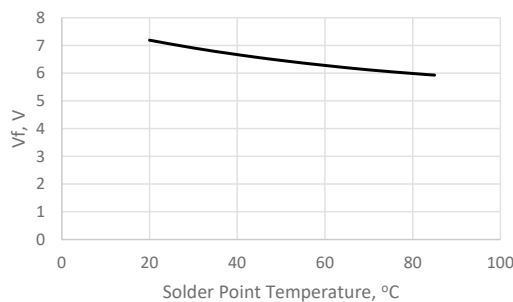
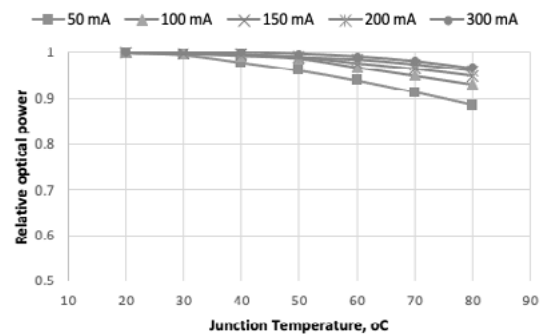
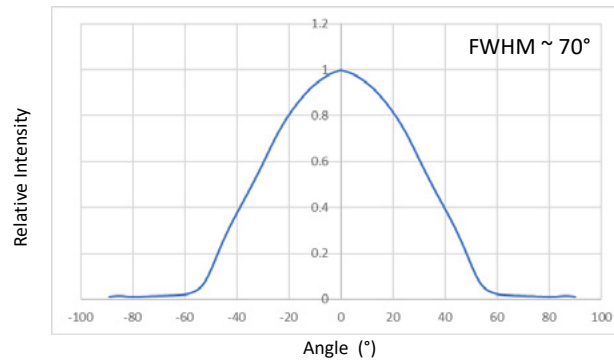

Figure 6. Radiant Flux vs. solder point temperature



S3535-H-DR350-270nm LEDs Specifications

Figure 7. Far-field Emission Pattern (Intensity vs. Emission Angle)



6. Lifetime at 350mA at Ta=25°C

Parameter	Symbol	Unit	Typ.
70% Power Lifetime	L70	hours	10000*
50% Power Lifetime	L50	hours	15000*

*Values based on standard Bolb test conditions 30°C +/- 2°C solder-point temperature
Subject to change: please inquire about latest update

Additional Testing and Certifications:

- Moisture Sensitivity Test: MSL Rating 5
- BOLB LEDs are RoHS and REACH compliant
- Bolb LEDs produce zero ozone

S3535-H-DR350-270nm LEDs Specifications

7. Binning Information

[Ta =25°C, I_f = 350mA]

Designate ^[1]	Information	Code	Min	Typ.	Max.
W	Peak Wavelength (nm)	265 (L0)	260	265	270
		270(L1)*	265	270	275
P	Radiant Flux (Φ _e) (mW)	U1	130	150	160
		U2*	160	170	190
		U3 [§]	180	200	220
		U4 [§]	220	230	250
V	Forward Voltage (V)	V1	5.5	6	6.5
		V2*	6.0	6.5	7.0
		V3	6.5	7.0	7.5

Note:

1. Bin code definitions are as follows: Peak Wavelength = W ; Radiant Flux = P ; Forward Voltage = V
2. * These are the **dominant bins**. Delivery time may be longer for other bins, if available.
3. [§] New for Q1, 2026, in limited supply. Please get in touch with Bolb for availability at info@bolbinc.com.

S3535-H-DR350-270nm LEDs Specifications

8. Target Surface Irradiance as a Function of Distance Normalized to 150 mW Output Power.

Scale linearly for LEDs with different output power (e.g. 1.25x for 200mW LEDs.)

LED Device	Distance to Target Plane (cm)	Irradiance Unit	Irradiance Values (±5%)				
			Irradiance on-axis	Irradiance 20cm off-axis	Irradiance 50cm off-axis		
S3535-H 150 mW 70°FWHM	0.5	mW/cm ²	175	N/A			
	1		92				
	1.5		41				
	2		25				
	3		14				
	5		5.2				
	10	μW/cm ²	1206	N/A			
	15		519				
	20		314			36	0.45
	40		63.1			31	4.4
	60		33.6			22	5.7
	80		18.2			15	5.9
	100		12.1			11	5.3
	120		9.05			7.8	3.5

Note:

1. Radiometers calibrated for the 253.7 nm main emission of mercury lamps require recalibration for 265 nm UVC emission;
2. Silicon carbide photodetectors are preferred over silicon alternatives, eliminating the need for frequent recalibration due to their superior resistance to degradation under intense UVC exposure.

S3535-H-DR350-270nm LEDs Specifications

9. Irradiance-Distance Plots for the SMD 3535-H Normalized to 150 mW Output power.

Scale linearly for LEDs with different output power (e.g. 1.25x for 200mW LEDs.)

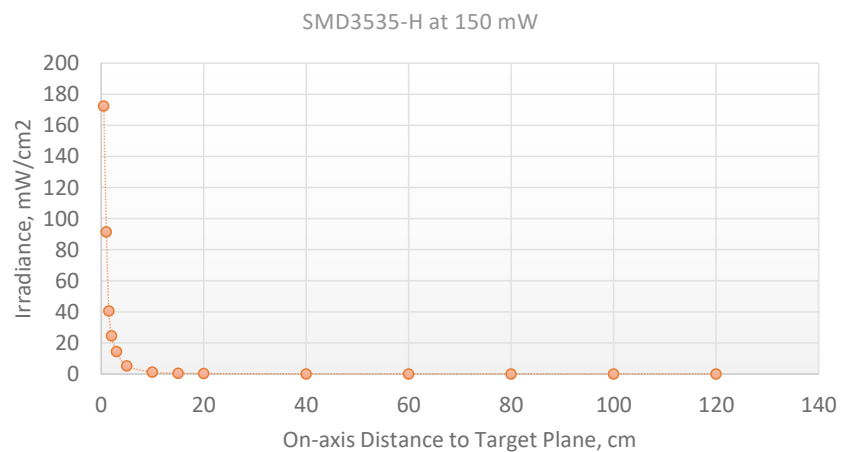
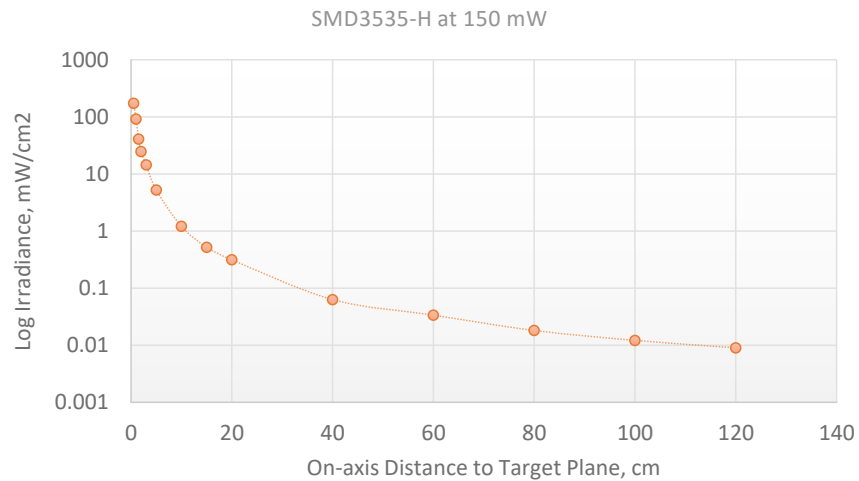

S3535-H-DR350-270nm LEDs Specifications

10. Solder Reflow Temperature Profile

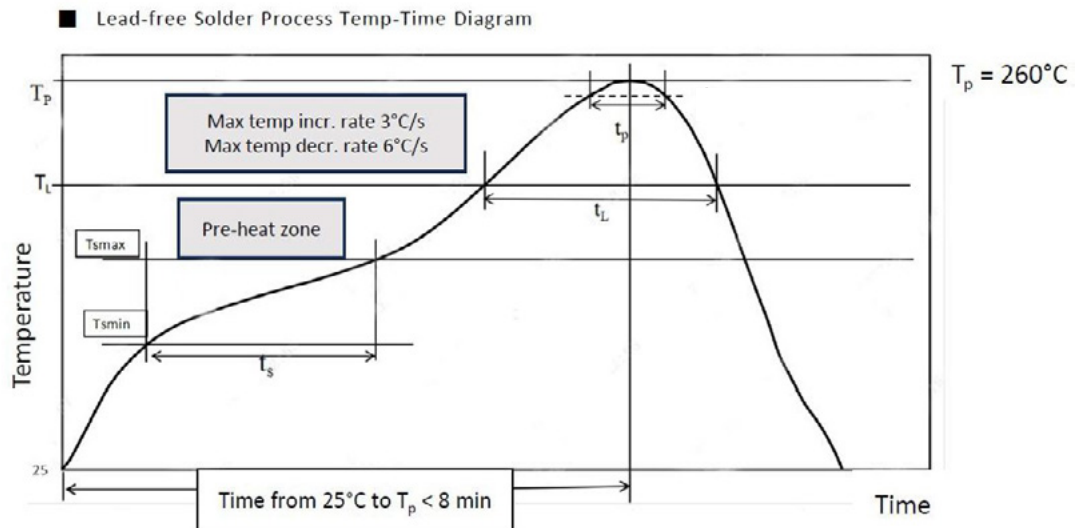

Reflow Steps	Lead-free soldering process parameters
Average heating rate (T_L to T_p)	Maximum value 3°C/s
Minimum value of preheating temperature T_{smin}	150°C
Maximum preheating temperature T_{smax}	200°C
Warm-up time t_s	60s-120s
Reflow zone maintenance temperature T_L	217°C
Reflow zone holding time t_L	60s-150s
Peak temperature T_p	260°C
t_p within 5°C of actual peak temperature	10s-30s
Cooling rate T_p to T_L	Maximum value 6°C/s
Time from 25°C (normal temperature) to peak temperature	Maximum time 8min

S3535-H-DR350-270nm LEDs Specifications

10. Solder Reflow Temperature Profile (continued)

Soldering Guidelines

1.Reflow Temperature: Optimize settings based on solder paste properties, equipment specifications, and PCB characteristics.

2.Soldering Methods:

1. Reflow soldering: Maximum 2 cycles permitted
2. Manual soldering: Maximum temperature 300°C for 2 seconds, single application only

3.Cooling: Gradual cooling from peak temperature recommended.

4.Process Curves: Provided curves are reference guidelines. Optimize based on specific application requirements.

5.Lead-Free Reflow Profile: Maximum temperature 260°C, not to exceed 20 seconds to prevent LED failure.

6.Atmosphere: Nitrogen-rich environment preferred for reflow soldering.

7.Flux: Use hydrogen-free flux in solder paste

S3535-H-DR350-270nm LEDs Specifications

11. Reliability

(1) Test and results

Test	Reference Standard	Test Conditions	Test Duration	Failure Criteria #	Failed/Tested
Resistance to Soldering Heat (Reflow Soldering)	JEITA ED-4701 300 301	T _{sld} =165°C, 10sec, 2 reflows		#1	0/10
Thermal Shock (Air to Air)		-40°C to 100°C, 15 mins dwell	1000cycles	#1	0/10
High Temperature Storage	JEITA ED-4701 200 201	T _a =100°C	1000hrs	#1	0/10
Low Temperature Storage	JEITA ED-4701 200 202	T _a =-40°C	1000hrs	#1	0/10
Room Temperature Operating Life		T _a =25°C, I _f =350mA, Test Board: See Notes Below	1000hrs	#1	0/10
High Temperature Operating Life		T _a =60°C, I _f =350mA, Test Board: See Notes Below	1000hrs	#1	0/10
Low Temperature Operating Life		T _a =10°C, I _f =350mA, Test Board: See Notes Below	1000hrs	#1	0/10
Electrostatic Discharges(with TVS)	JEITA ED-4701 300 304	HBM, 4KV, 1.5kΩ, 100pF 3 pulses, alternately positive or negative		#1	0/10

Notes: Aluminum PCB board=1.5mm, R_{θJA}=25°C/w

S3535-H-DR350-270nm LEDs Specifications

(2) Failure Criteria

Criteria #	Items	Conditions	Failure Criteria
#1	Forward Voltage(Vf)	IF=350mA	>initial value *1.1 <initial value *0.85
	Radiant Flux(ØE)	IF=350mA	<initial value *0.7

12. Storage Condition

Conditions		Temperature	Humidity	Time
Storage	Before opening aluminum ESD bag	<=30°C	<=90%RH	With 1 year from delivery
	After opening aluminum ESD bag	<=30°C	<=60%RH	<=48hr
Baking		65±5°C		>=24hr

Storage and Handling Notes

1. Moisture Sensitivity: LEDs are moisture-sensitive; store in sealed, moisture-proof packaging;
2. Assembly Window: Solder LEDs to PCBs within 24 hours of opening moisture-proof packaging to ensure optimal performance;
3. Extended Storage: For unused LEDs after 48 hours, store in a nitrogen-purged dry box to maintain quality.

S3535-H-DR350-270nm LEDs Specifications

13. Handling Procedures: ESD Protection

Adhere to JEDEC standard JESD625B or IEC 61340-5-1,2,3 for workplace setup. Implement the following guidelines for UVC LED handling:

1. **Operator Protection:** Wear and continuously monitor grounded conductive wrist straps when handling UVC LEDs.
2. **Static Neutralization:** Utilize ion blowers to mitigate static buildup on UVC flip chip surfaces during storage and handling.
3. **Storage:** Maintain UVC flip chips in protective ESD storage bags. Consider additional ESD protection (e.g., TVS protection diode) based on application requirements. Note: Bolb UVC LEDs include an integrated TVS chip.
4. **Handling:**
 - Use tweezers for LED manipulation. Teflon-coated tweezers are recommended to prevent scratching.
 - Avoid applying pressure to packaged LED lenses.
5. **Training:** Ensure proper operator training on all handling procedures.

S3535-H-DR350-270nm LEDs Specifications

14. Shipping Reel Information

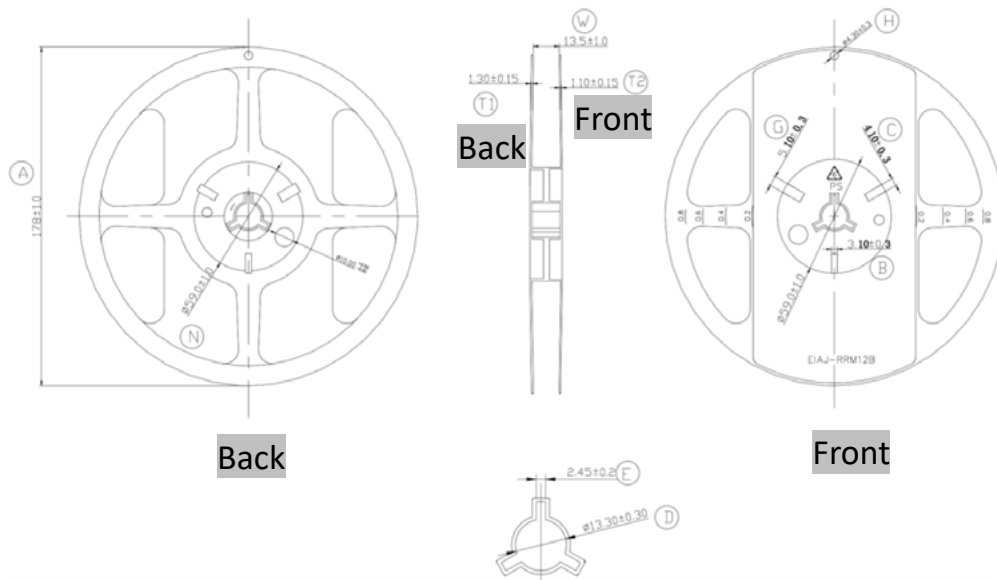
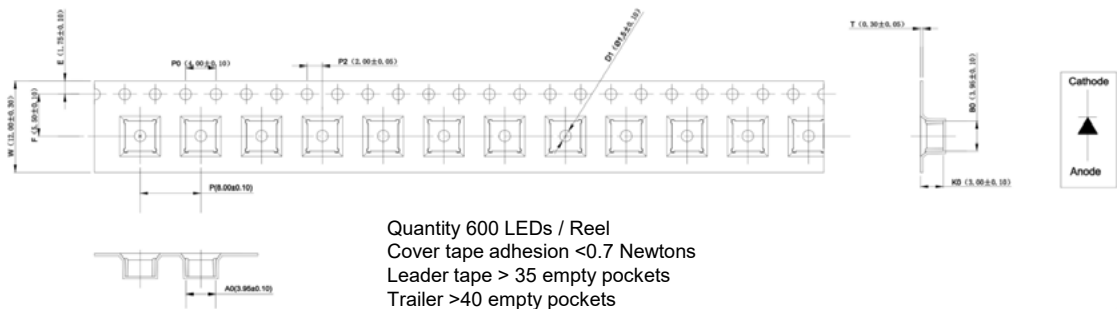

S3535-H-DR350-270nm LEDs Specifications

15. General Precautions and UVC Safety



WARNING UV emitted from this product. Avoid eye and skin exposure to unshielded product

AVERTISSEMENT UV émis par ce produit. Éviter l'exposition des yeux et de la peau à un produit non protégé

ADVERTENCIA Emisión de rayos ultravioleta por este producto. Evite la exposición de los ojos y la piel al producto sin protección

警告 この製品から放出される紫外線。シールドされていない製品への目や皮膚の露出を避ける

UVC LEDs emit deep ultraviolet radiation with extremely high intensity near their surface. High irradiance allows rapid disinfection, but users must observe safety precautions during assembly, testing, and field use.

By purchasing the UVC chips (bare dice), packaged LEDs, or arrays from BOLB Inc., the customer agrees to indemnify the manufacturer of any bodily harm due to failure to follow the common-sense precautions or warnings and guidelines contained within this Specification.

It is the buyer's responsibility to design products that ensure the safety of end users.

All assembly workers, operators, and bystanders must wear eye and skin protection when the UVC LEDs are energized. Therefore, bare-eye observation (including through microscopes) and bare-hand handling of a UVC LED in operation is **PROHIBITED**.

Because most materials readily absorb UVC light, any oil or other absorbent liquid or solid substance must **NOT** be allowed to touch the sapphire side of the UVC chip, the quartz window or dome lens on a packaged LED.

S3535-H-DR350-270nm LEDs Specifications



Special Notes on Circuit Design, LED Handling and Integration

- **Driver Headroom:** Design the constant-current driver with adequate forward-voltage margin. Driver compliance up to **7.5-8 V per LED** is recommended.
- **Thermal Control:** Monitor LED solder-point temperature during circuit prototyping. For best lifetime, keep **$T_s \leq 45^\circ\text{C}$** .
- **Lens Protection:** Avoid conformal coating, waterproofing spray, or other stray chemicals contacting the lens surface. **Most of these chemicals will yellow** under UVC exposure and cause long term reliability issues.
- **Solder Flux Control:** Avoid excess flux smoke or flux residue contamination on the lens. **No-clean solder** is recommended.
- **Clean Handling:** **Do not touch the lens** with bare or contaminated gloves/hands. Avoid contamination from thermal compound, solder, or other residues.