



660nm 1mW Linearly Polarized Single Mode VCSEL Diode VD-0660I-001M-XX-XXX

FEATURES

- Single transverse and longitudinal mode
- Linear Polarization stable
- Wavelength tunable via temperature and current scanning
- Small emission area, easy to collimate
- High SMSR and PER
- High reliability

APPLICATIONS

- Sensing applications
- Laser doppler measurement
- FTIR spectroscopy
- Optical coherence tomography
- Oxygen measurement
- Medical applications
- Quantum /optical communications

PRODUCT IDENTIFY

Part Number	Description
VD-0660I-001M-XX-XXX	660nm 1mW Linearly Polarized Single mode VCSEL Diode

Code Rules

VD - 0660 I - 001 M - X X - X X X
 ① - ② ③ - ④ ⑤ - ⑥ ⑦ - ⑧ ⑨ ⑩

⑩	Annex, 0, I=TEC
⑨	Product Version, A, 1
⑧	Accessories, A= Linearly Polarized Single mode and 4=Lens
⑦	Package, C=3535, I=TO46
⑥	Substrate, 1=AlN, 5=NiFe
⑤	Power units, M =milliwatts
④	Power value, 1
③	Classification, I=Industrial
②	Wavelength, 660nm
①	Header, short form of VCSEL diode

I. Absolute maximum ratings

Parameter	Symbol	Rating	Unit
Case Operating Temperature	T _{op}	-40 to +85	°C
Storage Temperature	T _{sto}	-40 to +105	°C
Reflow Soldering Temperature	T _{sdr}	260°C (10s)	-
Reverse Voltage	V _r	5	V
Maximum Continuous Current	I _{max}	3.2	mA
ESD exposure (Human body) model	ESD	2-4K (Class 2)	V
ESD exposure (Machine) model	ESD	200-400 (Class B)	V



Moisture Sensitive Level	MSL	1-3	-
--------------------------	-----	-----	---

Note:

1. Stresses greater than those listed under “Absolute Maximum Ratings” may cause permanent damage to the device. This is a stress rating only and functional operation of the device at these or other conditions above those indicated in the operations section for extended periods of time may affect reliability.
2. In its maximum rating diode laser operation could damage its performance or cause potential safety hazard such as equipment failure.
3. Electrostatic discharge is the main reason for the laser fault of the diode. Take effective precautions against ESD. When dealing with laser diodes, use the wrist strap, grounding work surface and strict antistatic technology.

II. Optical-electrical characteristics @25°C , CW mode

Parameters	Symbol	Condition	Min.	Typ.	Max.	Unit
Optical Power	P _o	I _F =1.6mA	0.5	1	1.5	mW
Forward Current	I _F	-	0.9	1.6	2.3	mA
Threshold Current	I _{th}	-	-	0.32	-	mA
Laser Forward Voltage	V _f	I _F =1.6mA	2.7	2.9	3.3	V
Power conversion efficiency	η	I _F =1.6mA	18	21	-	%
Slope efficiency	SE	P _o =1mW	-	0.78	-	W/A
Series Resistance	R	I _F =1.6mA	-	530	-	Ω
Peak Wavelength	-	I _F =1.6mA	655	660	675	nm
Wavelength current tuning coefficient	Δλ/ΔI	-	0.45	-	0.67	nm/mA
Single-mode suppression ratio	SMSR	-	30	50	-	dB
Polarization extinction ratio	PER	I _F =1.6mA	-	20	-	dB
Spectral width	SW	I _F =1.6mA	-	-	100	MHz
Wavelength-Temp. Drift	Δλ/ΔT	I _F =1.6mA	-	0.045	-	nm/°C
Beam divergence	FWHM	-	10	11	12	deg
	1/e ²	-	14	16	18	deg
Emission diameter	-	-	-	3	-	um
Rise time	-	20%-80%	-	80	-	ps
Fall time	-	20%-80%	-	80	-	ps
Beta Value	B	B=[ln(R1)-ln(R2)]/[1/T1-1/T2]	-	3930	-	K
TEC Voltage	V _{pe}	-	-	-	0.51	V
TEC Current	I _{pe}	-	-	-	0.96	A
TEC Efficiency	P _{pe}	-	-	-	0.29	W
Soldering Temperature	-	AlN, FeNi Alloy	-	-	260(10s)	°C
No. of Emission Aperture	-	-	-	1	-	-
Substrate	AlN, FeNi Alloy					

Note: Electro-Optical Characteristic with a package or diffuser would require further evaluation. Values are based on limited sample size and estimated values.



III. Typical Performance

LIV curve & Spectral Width

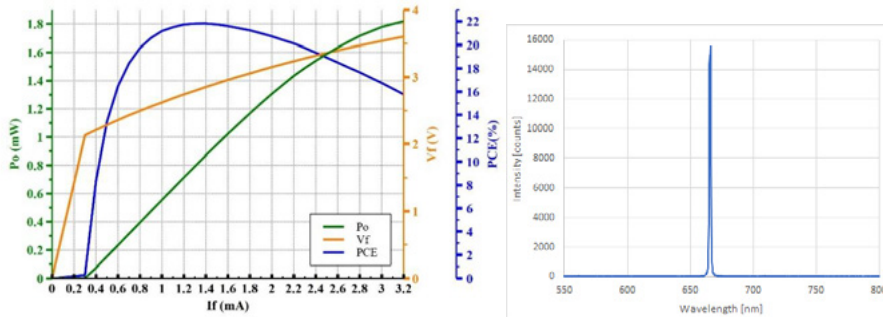

Note:

1. LIV graph was measured at 25 °C (left); power output, voltage and power conversion efficiency variation trend with changed operating temperature (right, normalized).
2. Forward Voltage (VF) measurement allowance is ± 0.1 V.
3. Peak Wavelength (λ_P) measurement allowance is ± 1.5 nm.
4. Others measurement allowance is $\pm 10\%$.

IV. Mechanical Schematics

VD-0660I-001M-5I-AA1 with Substrate 5=NiFe and Package I=TO46 with TEC (unit: mm)

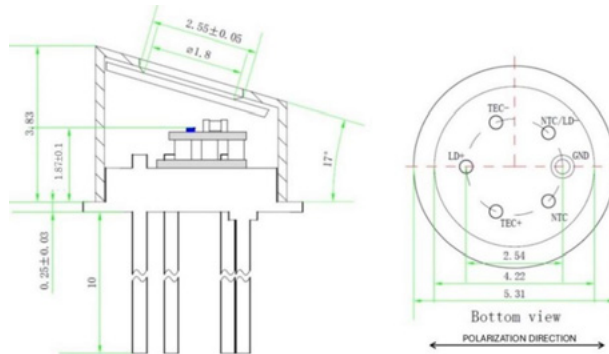

VD-0660I-001M-1C-AA0 with Substrate 1=AlN and Package C=3535 (unit: mm)

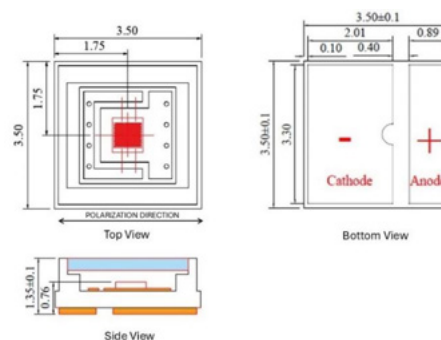



VD-0660I-001M-1C-410 with Substrate 1=AlN and Package C=3535 (unit: mm)

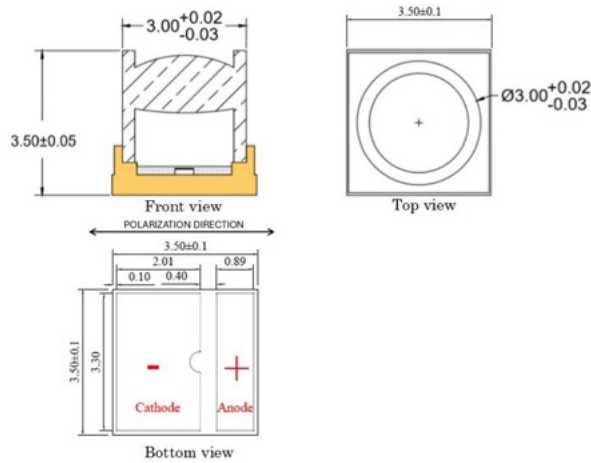

VD-0660I-001M-5I-AA0 with Substrate 5=NiFe and Package I=TO46 (unit: mm)

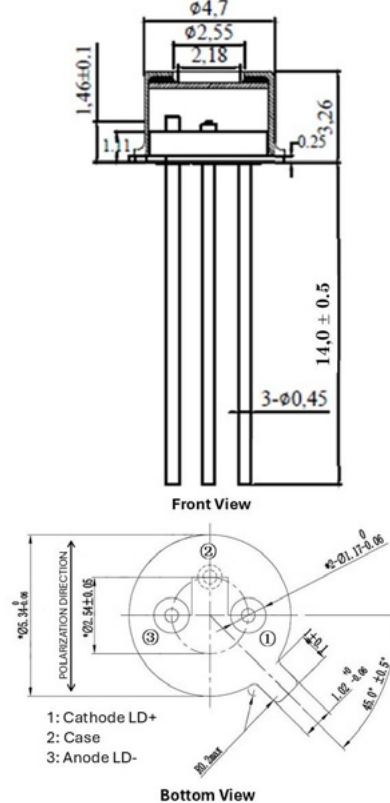

Note: There may be some changes between sample and drawing · thus · the actual spec please refer to the sample that you received. And if any inquires please contact us.



V. SMT Reflow Soldering Curve

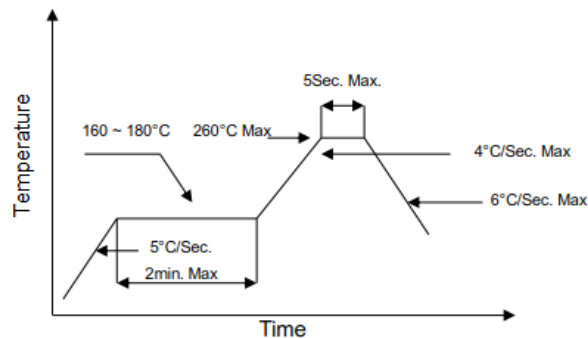

Note: Reflow soldering can be operated only one time. During the temperature ramp-up, no forces may be exerted on the diode which could deform or damage them. After soldering completed, please also do not process until the product temperature ramp down to room temperature.

VI. Treatment and protection measures

Soldering precautions

The temperature of soldering iron must be controlled under 300°C during manual soldering. Also, VCSEL can be only soldered one time with the soldering time less than 3s. but, it is very hard to control the soldering temperature and homogenize solder paste because of the smaller size of VCSEL. In addition, it is easy to damage VCSEL structure even causes VCSEL losing efficacy. So, we advise you to use re-flow soldering machine for operation.

Storage precautions

Our products were sealed by aluminum foil bag attaching packed desiccant, they are moisture proof and anti-static. Please handle these gently to avoid damage. At the same time, please be ready for storage and take some moisture-proof measures to keep the diode away from dampness that may causes reliability failure.

Before opening, the diode must be saved for at least 90 days below 30 °C with 60% RH.

After opening, the diode must be kept in an environment that temperature lower than 30 °C and humidity lower than 60% RH and used up within 24 hours. When the storage humidity reaches and exceeds 60%, the products must be dehumidified at 60 °C for more than 24 hours before use.

Others

1. Please use solder paste to cure the laser diode.
2. Please make sure that the heat of the diode has been completely conducted to metal shell, to avoid affecting the optical power output.
3. This diode can be operated in constant voltage and current of pulsed and continuous mode both.
4. Operating voltage and current, refer to the table in paragraph II.
5. Please do not aim the laser to people or animal.
6. You can observe the laser spot through an image monitoring equipment.
7. Please do not touch the diode surface by naked hands or squeeze the sealant on the diode surface, or it may cause wrong optical angle and distorted laser spot, even damage the diode.
8. Please use ceramic suction nozzle to absorb the diode, to avoid the diode sticking to the nozzle.
9. Please add a 0.02 s blowing action after locating the laser diode to aluminum substrate.



VII. Revision History

Revision	Date	Description
V.00	2025/12/23	Preliminary version (660-1)
V.00a	2026/01/12	Add polarization direction
V.01	2026/02/02	The first official edition
V.02	2026/02/04	Update TO46 (-5I-AA0) Anode/Cathode pin definition

Note: Brightlaser reserves the right to make modification at any time due to improved design from time to time, the merit behind is to supply the best product possible.

Laser diode product components are intended for use in a user-devised end system. However, these products are capable of emitting laser radiation. Extreme care must be exercised during their operation. Only persons familiar with the appropriate safety precautions should operate a laser product. Directly viewing the laser beam or exposure to specular reflections must be avoided. Serious injury may result if any part of the body is exposed to the beam. The eye is extremely sensitive to the infrared radiation and therefore, proper eye wear must be worn at all times. Use of optical instruments with these products may increase eye hazard. Always wear eye protection when operating.

