

iC-WK DEMO WK4D DEMO BOARD DESCRIPTION

Rev A1, Page 1/3

ORDERING INFORMATION

Type	Order Designation	Description/Options
iC-WK Demo	WK4D DEMO	Evaluation boards for iC-WK, iC-WKL and iC-WKN; easy to set up for the booster circuit from the iC-WK/L Application Notes
iC-WKL Demo	WKL4D DEMO	
iC-WKN Demo	WKN4D DEMO	

BOARD WK4D

(size 100 mm x 80 mm)

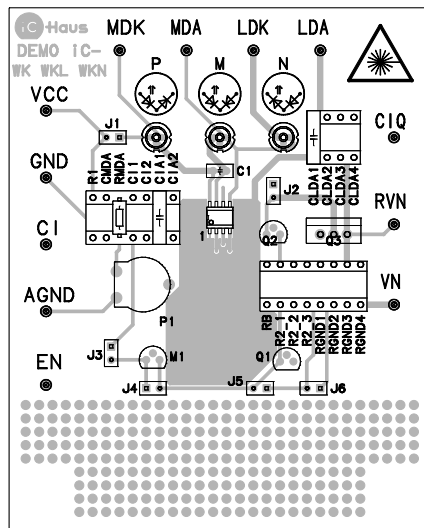

Figure 1: Component side of WK4D board

TERMINAL DESCRIPTIONS

Name	Function
VCC	Supply Voltage
GND	Ground
CI	Capacitor for Power Control
AGND	Reference Ground for CI, RM
EN	Switching Input for Booster Circuit
MDK	Monitor Input for P-Type Laser Diodes
MDA	Monitor Input for N/M-Type Laser Diodes
LDK	Driver Output
LDA	Laser Supply/Positive Supply Terminal of Booster Circuit
CIQ	Internal Ground of iC-WK/WKL with Booster Circuit
RVN	Sense Resistor for Overcurrent Shutdown of Booster Circuit
VN	Ground Terminal of Booster Circuit

Copyright © 2003, iC-Haus

iC-WK DEMO WK4D DEMO BOARD DESCRIPTION

Rev A1, Page 2/3

DESCRIPTION

The iC-WK/L/N evaluation boards come pre-assembled for use with the RLD-65NE laser diode. The default assembly and current path is highlighted in the below schematic diagram. For hints on dimensioning and other configurations (eg. an external booster circuit) see the application notes on iC-WK/L, available as a separate document.

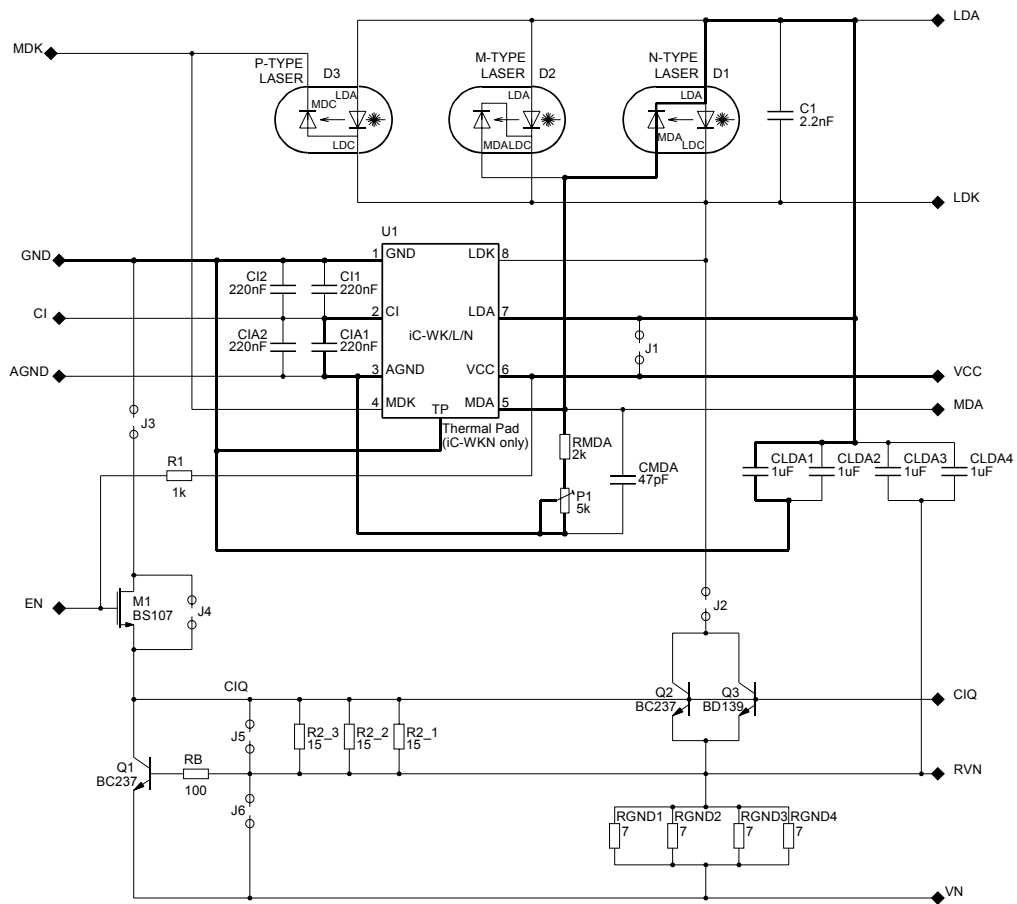

Figure 2: Schematic diagram of WK4D board (default configuration highlighted).

iC-WK DEMO WK4D DEMO BOARD DESCRIPTION

Rev A1, Page 3/3

ASSEMBLY PART LIST

Device	Value (typ)	Comment
C1	2.2 nF	optional: ESD protection for the laser diode; use with longer leads to the laser diode
CI#, CIA#	100 nF	power control capacitors
CLDA#	1 μ F	blocking capacitors; use CLDA3 or CLDA4 with booster circuit
CMDA	47 pF	optional: blocking capacitor, reduces sensitivity to external interferences; P1 + RMDA has to be limited to 25k Ω , increase CI/CIA to \geq 220nF and CLDA to 2 μ F; check for oscillation at pin MDA, increase CI/CIA if necessary
D1		n-type laser diode
D2		m-type laser diode
D3		p-type laser diode
J1	open	short for laser currents > 70mA (iC-WK/L only)
J2	open	short for booster
J3	open	short for booster
J4	open	open to activate M1 (with booster)
J5	open	
J6	open	
M1	BS107	optional: switching transistor
P1	5k Ω	trimmer to set the laser output power
Q1	BC237	optional: overcurrent shutdown for booster
Q2	BC237	optional: booster
Q3	BD139	optional: booster for high currents
R1	1k Ω	optional: pull-up for M1
R2	15 Ω	optional: sets the laser current current iC-WK/L takes when the booster is used; R2 = Ube(Q2 or Q3) / 45 mA
RB	100 Ω	optional: use with Q1
RGND#	open	optional: sets the overcurrent shutdown threshold (Ioff) of the booster; RGND = Ube(Q1) / Ioff
RMDA	2k Ω	sets the maximum output power (P1 turned to 0 Ω)
U1	iC-WK/L/N	

This specification is for a newly developed product. iC-Haus therefore reserves the right to change or update, without notice, any information contained herein, design and specification; and to discontinue or limit production or distribution of any product versions. Please contact iC-Haus to ascertain the current data. Copying - even as an excerpt - is only permitted with iC-Haus approval in writing and precise reference to source.

iC-Haus does not warrant the accuracy, completeness or timeliness of the specification on this site and does not assume liability for any errors or omissions in the materials. The data specified is intended solely for the purpose of product description. No representations or warranties, either express or implied, of merchantability, fitness for a particular purpose or of any other nature are made hereunder with respect to information/specification or the products to which information refers and no guarantee with respect to compliance to the intended use is given. In particular, this also applies to the stated possible applications or areas of applications of the product.

iC-Haus conveys no patent, copyright, mask work right or other trade mark right to this product. iC-Haus assumes no liability for any patent and/or other trade mark rights of a third party resulting from processing or handling of the product and/or any other use of the product.