

ModBox-CBand-DPSK series

C-Band, 12 Gb/s Reference Transmitters

MODBOX



FEATURES

- Full C-Band Reference Transmitter
- Up to 12 Gb/s
- Reliable & reproducible measurements
- High eye diagram stability

APPLICATIONS

- Transmission system test
- Components characterization
- Production test
- R&D laboratories

OPTIONS

- Tunable Laser source, C-Band, L-Band
- DPSK encoder
- Receiver stage
- Fixed, tunable FSR optical demodulator
- 28 Gb/s version
- Multi-formats version:
NRZ & RZ, NRZ & RZ-DPSK, CS-NRZ-DPSK

The ModBox-CBand-DPSK is an optical modulation unit that generates high performance DPSK optical data streams up to 12.5 Gb/s. The equipment incorporates a modulation stage based on a high data rate LiNb₃ Mach-Zehnder modulator, coupled with a high performance RF driver and an automatic bias control circuitry. It can also receive an internal laser source (DFB, ITLA...), a receiver stage based on a delay line interferometer and balanced detector.

The ModBox-CBand-DPSK provides R&D and production engineers with state of the art performance and the peace of mind of a turn-key instrument. It can be used as a reference transmitter in optical telecommunications laboratories, or in production test beds.

In addition to the traditional 1550 nm wavelength range, it is also available at 1310 nm.

Performance Highlights

Parameter	Min	Typ	Max
Operating wavelength	-	C-Band	-
Modulation format	DPSK		
Modulation bandwidth	12.5 Gb/s		

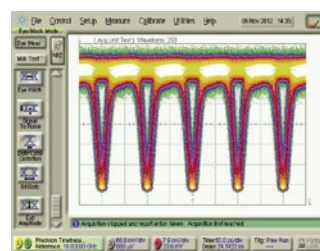

10 Gb/s Optical DPSK Eye Diagram

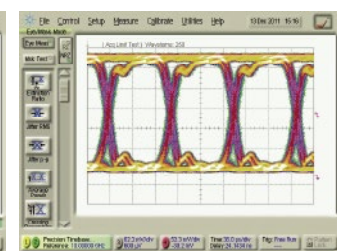

10 Gb/s Electrical Demodulated Eye Diagram

ModBox-CBand-DPSK series

C-Band, 12.5 Gb/s Reference Transmitters

MODBOX

Functional Block Diagram

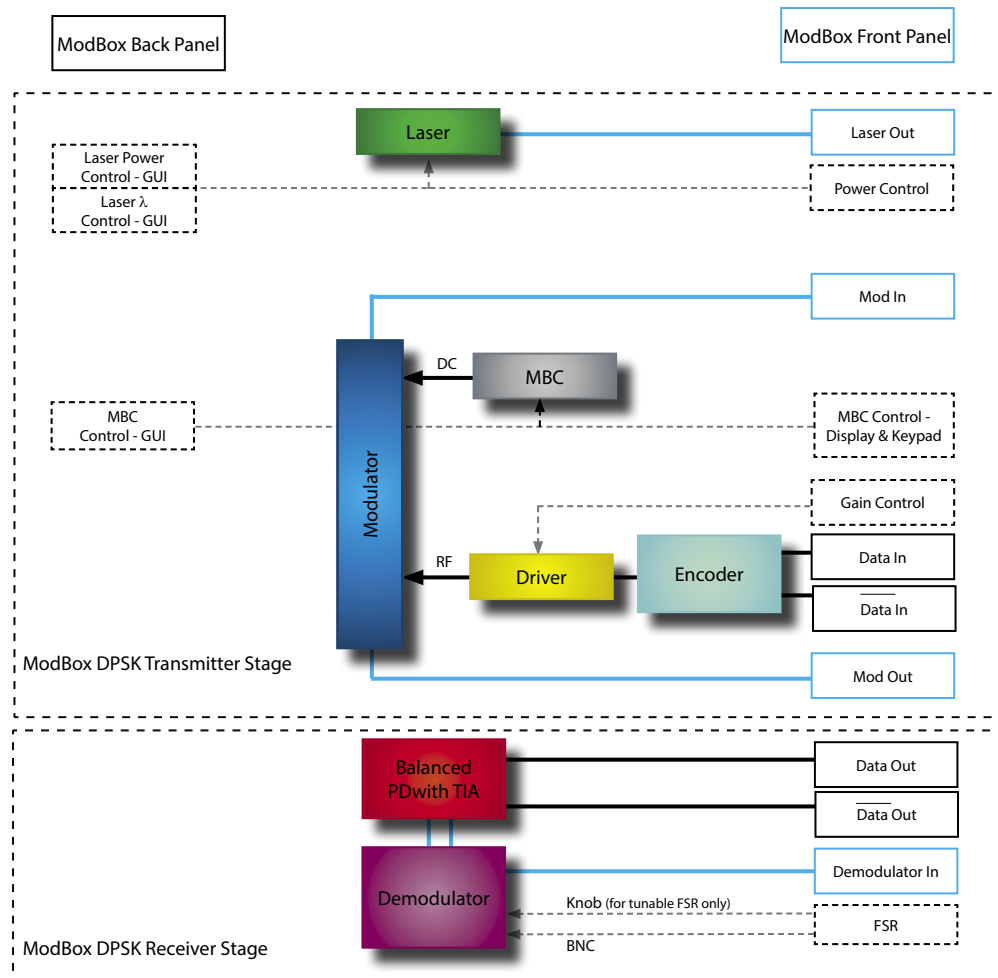

The ModBox-CBand-DPSK integrates:

- a high bandwidth, chirp-free, X-cut LiNb₃ Mach-Zehnder modulator,
- a high bandwidth NRZ RF driver with gain level adjustment for eye diagram optimization,
- a bias control circuit to lock the Mach-Zehnder modulator and ensure a highly stable output optical signal,
- an optional laser source, DFB or tunable type, with its high precision driver that allows control of output power,
- an optional electrical encoder,
- an optional receiver stage composed of one optical demodulator (fixed or tunable FSR) and balanced photodiodes.

ModBox-CBand-DPSK series

C-Band, 12.5 Gb/s Reference Transmitters

MODBOX

Input Electrical Specifications User supplied, not a ModBox specification

Parameter	Symbol	Condition	Min	Typ	Max	Unit
Data-rate	PRBS	NRZ	0.1	-	12.5	Gb/s
Input voltage	V_{IN}	AC coupled - 50 Ω - Single ended	0.400	0.450	0.500	Vpp
Jitter	J_{RMS}	-	-	1	1.2	ps
Rise / fall time	t_r / t_f	20 % - 80 %	-	40	-	ps

Input Optical Specifications User supplied, not a ModBox specification

Parameter	Symbol	Condition	Min	Typ	Max	Unit
Operation	λ	CW	1520	-	1565	nm
Polarization	-	-	Linear and controlled			-
Power	P	-	-	-	100	mW
Side Mode Supression Ratio	SMSR	-	30	-	-	dB
Spectrum linewidth	$\Delta\lambda$	FWHM	-	1	-	MHz
Relative Intensity Noise	RIN	0.2 GHz - 3 GHz	-	-150	-	dB/Hz

Modulated Output Optical Specifications Specifications below are given with embedded 1550 nm

Parameter	Symbol	Condition	Min	Typ	Max	Unit
Data-rate	-	DPSK	0.1	-	12.5	Gb/s
Dynamic Signal to Noise Ratio	SNR	-	25	-	-	-
Rise / fall time	t_r / t_f	20 % - 80 %	-	40	-	ps
Electrical Return loss	ORL	-	-40	-45	-	dB
Insertion loss	IL	At maximum modulator transmission	-	4	6	dB

Demodulated Output Optical Specifications Measured with ModBox DPSK Transmitter and Receiver Stages.

Parameter	Symbol	Condition	Min	Typ	Max	Unit
Data-rate	-	Differential	-	-	12.5	Gb/s
Output eye amplitude	-	Single ended	-	250	-	mV
Rise / fall time	t_r / t_f	20 % - 80 %	-	40	-	ps
Added jitter	J_{RMS}	-	-	3	-	ps
Dynamic Signal to Noise Ratio	SNR	-	-	15	6	-

Absolute Maximum Ratings - ModBox DPSK Transmitter without any options

Stresses in excess of the absolute maximum ratings can cause permanent damage to the device. These are absolute stress ratings only. Functional operation of the device is not implied at these or any other conditions in excess of those given in the operational sections of the data sheet. Exposure to absolute maximum ratings for extended periods can adversely affect device reliability.

Parameter	Symbol	Min	Max	Unit
Input voltage	V_{IN}	-	1	Vpp
Optical input power	OP_{in}	-	20	dBm

ModBox-CBand-DPSK series

C-Band, 12.5 Gb/s Reference Transmitters

MODBOX

Optional C-Band DFB Laser Specifications

Parameter	Symbol	Condition	Min	Typ	Max	Unit
Wavelength	λ	Other wavelength on request	1550.12 nm - ITU CH 34 *			-
Laser type	-	-	DFB			-
Optical output power	-	CW	-	40*	-	mW
Spectrum linewidth	$\Delta\lambda$	FWHM	-	-	1	MHz
Optical return loss	ORL	-	30	35	-	dB
Side mode suppression ratio	SMSR	-	30	-	-	dB
Optical output power adjustment	P_{CW}	Front & back panels with GUI	20	-	40	mW
Wavelength laser tuning range	-	Back panel with GUI	-	0.8	1	nm

C-Band Tunable Laser Specifications

Parameter	Symbol	Condition	Min	Typ	Max	Unit
Laser type	-	-	Tunable			-
Wavelength	λ	Embedded by default	1527.60	-	1565.50	nm
Wavelength accuracy	$\Delta\lambda_{acc}$	-	-1.5	-	1.5	GHz
Spectrum linewidth	$\Delta\lambda$	FWHM @-3 dB, instantaneous	-	-	100	kHz
Optical output power	-	CW	5	-	35	mW
Optical output power adjustment	-	-	0	-	100	%
Optical Return Loss	ORL	-	30	-	-	dB
Side Mode Suppression Ratio	SMSR	-	40	-	-	dB

Optional Encoder Specifications

The encoder option is a NRZ differential coder for high data rate application. The device has two high frequency differential inputs (Data & Clock). The encoder can be either used is 50 Ω single ended or 100 Ω differential. The input data stream is synchronized by the clock and electrically coded to a differential format. If a logical zero is present to the input, the output remains unchanged: $Q_{n+1}=Q_n$. If a logical one is present to the data input, the output value is changed at every rising edge of the clock: a constant one to the input gives a continuous series of 01010 to the output.

Parameter	Symbol	Condition	Min	Typ	Max	Unit
Data coding type	-	-	DPSK encoding			-
Data & Clock input impedance	Z_{IN}	Single ended	-	50	-	Ω
Data & Clock input amplitude	V_{IN}	Single ended or Differential	2	300	-	mV _{pp}
Output rise and fall times	t_r / t_f	10% - 90%	-	15	-	ps

ModBox-CBand-DPSK series

C-Band, 12.5 Gb/s Reference Transmitters

MODBOX

Optional Optical Demodulator with Fixed FSR (Kylia)

The DPSK demodulator is a Delay Line Interferometer performing the interface between the signal and itself 1-bit delayed. It is tunable to perfectly match the carrier frequency.

Parameter	Symbol	Condition	Min	Typ	Max	Unit
Optical wavelength range	$\lambda_{C\text{-band}}$	C-band version	1527	1550	1565	nm
Free Spectral Range *	FSR	Fix	5, 10.7, 12			GHz
Decoding data-rate *	-	Fix	5, 10.7, 12			Gb/s
Insertion loss	IL	-	-	2	-	dB
Pol dependant frequency shift	PDFS	-	-	4	-	%FSR
Phase tuning range	-	-	-	-	1.5	FSR
Maximum optical input power	OP_{in}	-	-	-	300	mW

* Only typical values are listed. FSR ranging from 4.5 to 12 GHz can be provided.

Optional Optical Demodulator with Tunable FSR (Kylia)

Parameter	Symbol	Condition	Min	Typ	Max	Unit
Optical wavelength range	$\lambda_{C\text{-band}}$	C-band version	1527	-	1565	nm
FSR tuning range	ΔFSR	Manual adjustment using knob	4.5	-	10	GHz
Decoding data-rate range	-	-	4.5	-	10	Gb/s
Phase tuning range	-	-	-	-	1.5	FSR
Tuning voltage	-	User supplied, with voltage input -BNC	0	-	4	V
Insertion loss	IL	-	-	3.5	-	dB
Tuning	ΔIL	-	-	0.5	-	dB
Pol dependant frequency shift	PDFS	-	-	4	-	%FSR
Maximum optical input power	OP_{in}	-	-	-	300	mW

Optional Optical Photoreceiver Specifications

Parameter	Symbol	Condition	Min	Typ	Max	Unit
Photodetector type	-	-	Balanced PIN photodiodes with TIA			-
Operating wavelength range	λ	-	1480	-	1620	nm
Maximum bit rate	-	-	-	-	20	Gb/s
PD responsivity	S	Average polarization @1550 nm	0.85	0.92	-	A/W
Conversion gain *	CG	@-10 dBm NRZ input	-	2 100	-	V/W
OSNR sensitivity	-	DPSK system with BER1e-3	-	+13	-	dBm
Maximum optical input power	P_{opt}	Into each PD (average level, NRZ)	-	-	+6	dBm
Maximum output swing	V_{out}	Differential	-	500	600	mV
Output rise and fall times	t_r / t_f	-	-	10	-	ps

ModBox-CBand-DPSK series
C-Band, 12.5 Gb/s Reference Transmitters

ModBox

Modulated DPSK Eye Diagrams from ModBox Transmitter

The following equipment was used in obtaining these results :

- Agilent Infinium DCA 86100B
- Anritsu synthesizer MG3694C
- Anritsu Signal Analyzer MP1800A
- Photodiode u^t XPDV2320R

5 Gb/s data rate

Input electrical signal

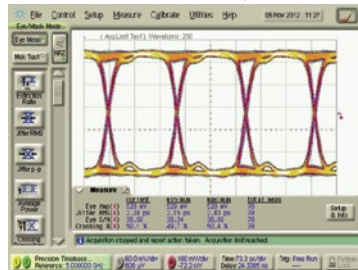

Eye Amp = 529 mV Jitter p-p = 11 ps
Jitter RMS = 2.2 ps Rise time (10/90) = 42 ps
Eye S/N = 38 Fall time (10/90) = 44 ps

DPSK Output optical signal

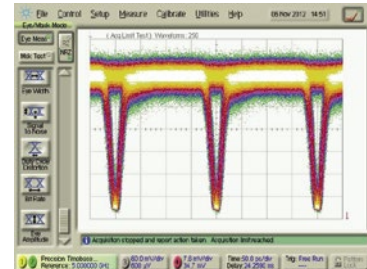

10 Gb/s data rate

Input electrical signal

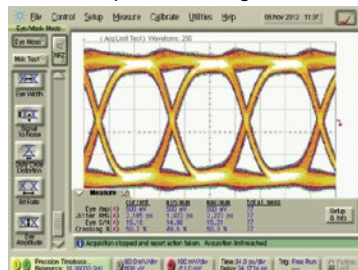

Eye Amp = 500 mV Jitter p-p = 12 ps
Jitter RMS = 2.18 ps Rise time (10/90) = 43 ps
Eye S/N = 15 Fall time (10/90) = 38 ps

DPSK Output optical signal

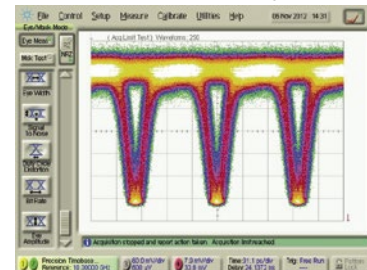

12 Gb/s data rate

Input electrical signal

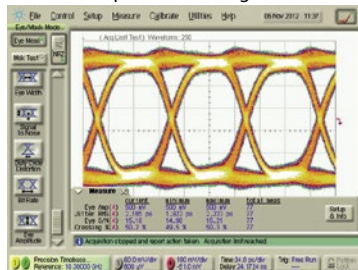

Eye Amp = 500 mV Jitter p-p = 12 ps
Jitter RMS = 2.18 ps Rise time (10/90) = 43 ps
Eye S/N = 15 Fall time (10/90) = 38 ps

DPSK Output optical signal

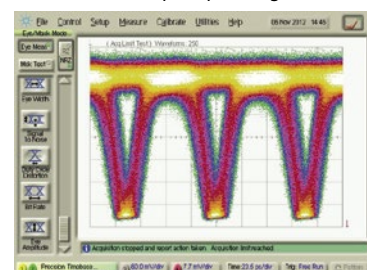

ModBox-CBand-DPSK series C-Band, 12.5 Gb/s Reference Transmitters

ModBox

10 Gb/s DPSK Modulation and Demodulation Set-up

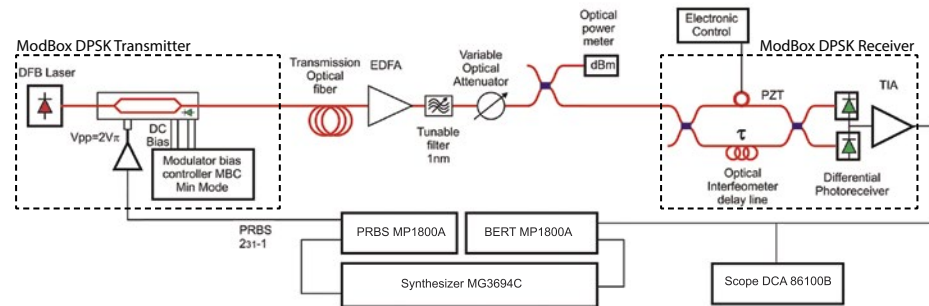

10 Gb/s Demodulated Eye Diagrams

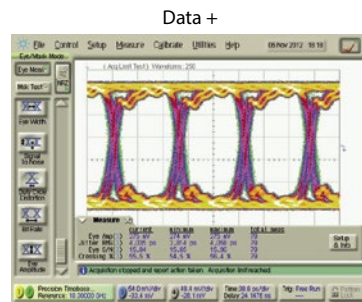

Eye Amp = 275 mV
Jitter p-p = 17 ps
Jitter RMS = 4 ps
Eye S/N = 15
Rise time (10/90) = 33 ps
Fall time (10/90) = 28 ps

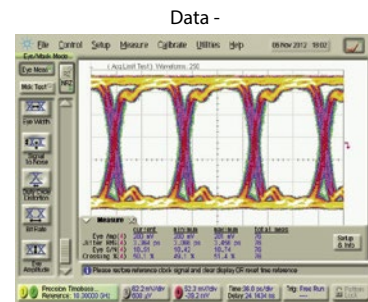

Eye Amp = 280 mV
Jitter p-p = 19 ps
Jitter RMS = 3.3 ps
Eye S/N = 18
Rise time (10/90) = 36 ps
Fall time (10/90) = 35 ps

10 Gb/s BER

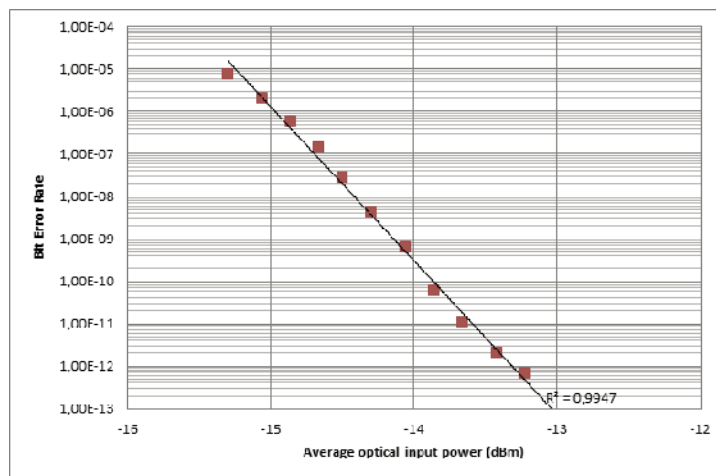

ModBox-CBand-DPSK series C-Band, 12.5 Gb/s Reference Transmitters

ModBox

Interfaces, Dimensions and Compliance

Interfaces	
Optical	Polarization maintaining fiber, PM1550 / SMF58 (demodulator)
RF input	Single SMA female RF connector - 50 Ω
Control	Smart Interface (front panel), GUI (USB typeB)
Power supply	100-120V/220-240 automatic switch 50-60Hz (Rear panel)
Dimensions / Weight	Rack 19" x 3U, Depth=375mm / 3 kg



Ordering information

ModBox-CBand-DPSK-XX

CBand = Full band of operation, embeds laser, C-Band Tunable laser by default
XX = Data-rate: 12.5Gb/s up to 12 Gb/s- 28Gb/s up to 28 Gb/s

Opt-YY

YY = Output connectors, FA : FC/APC - FC : FC/UPC - SA : SC/APC - SC : SC/UPC

About us

iXBlue Photonics produces specialty optical fibers and Bragg gratings based fiber optics components and provides optical modulation solutions based on the company lithium niobate (LiNbO₃) modulators and RF electronic modules.

iXBlue Photonics serves a wide range of industries: sensing and instruments, defense, telecommunications, space and fiber lasers as well as research laboratories all over the world.

iXblue reserves the right to change, at any time and without notice, the specifications, design, function or form of its products described herein. All statements, specification, technical information related to the products herein are given in good faith and based upon information believed to be reliable and accurate at the moment of printing. However the accuracy and completeness thereof is not guaranteed. No liability is assumed for any inaccuracies and as a result of use of the products. The user must validate all parameters for each application before use and he assumes all risks in connection with the use of the products