

Cooled Large Area Red Silicon Avalanche Photodiode
SD 197-70-72-591

Precision – Control – Results

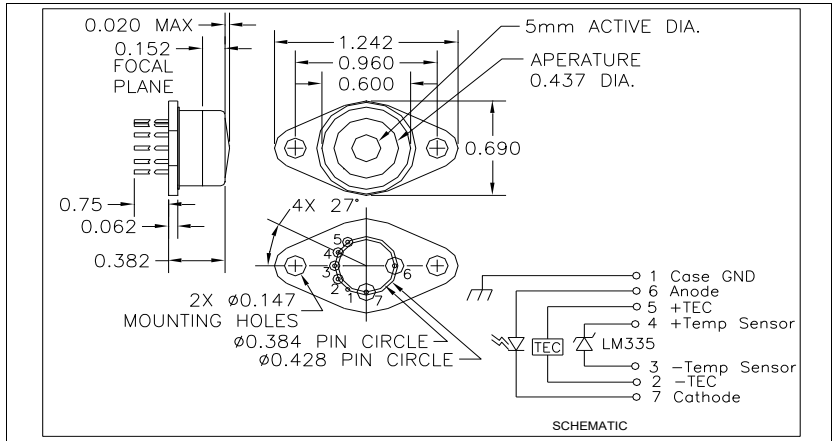
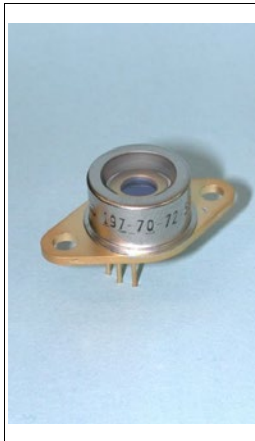

DESCRIPTION

The **SD 197-70-72-591** is a cooled large area silicon avalanche photodiode (APD) that provides high gain and low noise, in a hermetic TO-66 package.

FEATURES

- Low Noise
- Small Size
- High Speed
- Low Cost

RELIABILITY

Contact Luna for recommendations on specific test conditions and procedures.

APPLICATIONS

- Military
- Medical
- Industrial

ABSOLUTE MAXIMUM RATINGS

SYMBOL	MIN		MAX	UNITS	
Gain	-	-	350	V	T _a = 23°C UNLESS OTHERWISE NOTED
Storage Temperature	-55	to	+70	°C	-
Operating Temperature	+1	to	+40	°C	-
Soldering Temperature*	-	to	+240	°C	-
TEC voltage	-	-	1.5	V	-
TEC Current	-	to	2.0	A	-
APD Die Power Diss.	-	-	0.2	W	-

* 1/16 inch from case for 3 seconds max.

Information in this technical datasheet is believed to be correct and reliable. However, no responsibility is assumed for possible inaccuracies or omission. Specifications are subject to change without notice.

Cooled Large Area Red Silicon Avalanche Photodiode
SD 197-70-72-591

Precision – Control – Results

OPTO-ELECTRICAL PARAMETERS

T_a = 23°C UNLESS NOTED OTHERWISE

PARAMETER	TEST CONDITIONS	MIN	TYP	MAX	UNITS
Dark Current	-	-	10	25	nA
Junction Capacitance	f=1 MHz	-	25	-	pF
Noise Current Spectral Density	f=1 kHz	-	0.8	1.5	pA/√Hz
Spectral Application Range	Spot Scan	350	-	1050	nm
Responsivity	λ = 500nm, V _R = 0 V	-	95	-	A/W
Operating Voltage	-	1700	-	2000	V
Response Time**	RL = 50 Ω, λ = 675nm	-	10	15	nS
TEC Quiescent Current	Case Temp = 35° C	-	.85	-	A

**Response time of 10% to 90% is specified at 830nm wavelength light.

TYPICAL PERFORMANCE

SPECTRAL RESPONSE

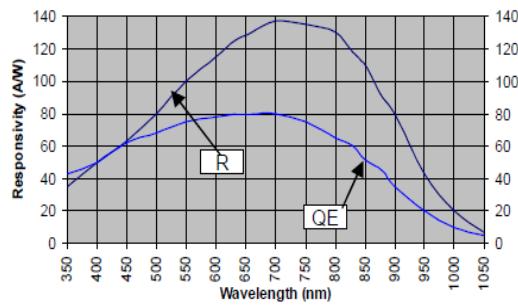

Information in this technical datasheet is believed to be correct and reliable. However, no responsibility is assumed for possible inaccuracies or omission. Specifications are subject to change without notice.

REV 01-04-16

© 2016 Luna Optoelectronics. All rights reserved.