

### SD 630-70-75-500

#### Non-Cooled Large Area DUV Silicon Avalanche Photodiode

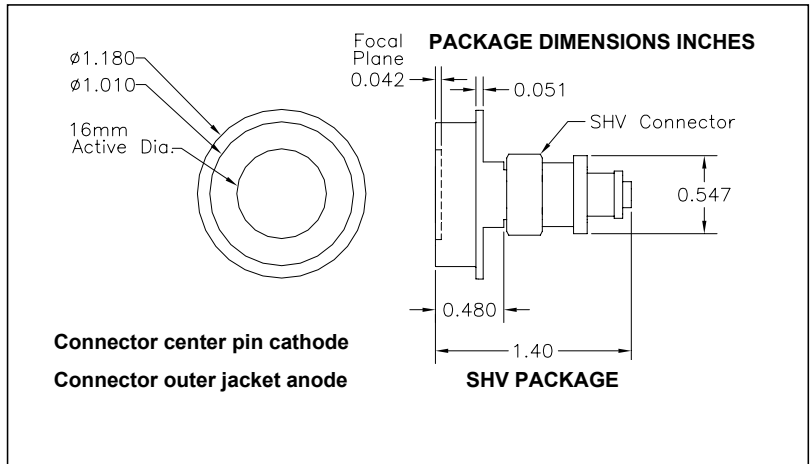

#### FEATURES

- Low noise
- High gain
- High Speed

#### DESCRIPTION

The **SD 630-70-75-500** is a windowless non-cooled large area DUV enhanced silicon avalanche photodiode (APD) with high gain and low noise in a SHV package.

#### APPLICATIONS

- Instrumentation
- Medical

#### ABSOLUTE MAXIMUM RATING (TA)= 23°C UNLESS OTHERWISE NOTED

SYMBOL	PARAMETER	MIN	MAX	UNITS
M	Gain		250	
T <sub>STG</sub>	Storage Temperature	-55	+70	°C
T <sub>O</sub>	Operating Temperature	-55	+40	°C
T <sub>S</sub>	Soldering Temperature*		+240	°C

\* 1/16 inch from case for 3 seconds max.

#### SPECTRAL RESPONSE M = 200

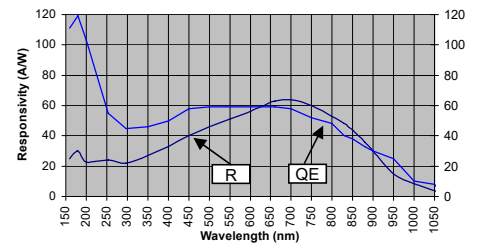

#### ELECTRO-OPTICAL CHARACTERISTICS RATING (TA)= 23°C and Gain of 200 UNLESS OTHERWISE NOTED

SYMBOL	CHARACTERISTIC	TEST CONDITIONS	MIN	TYP	MAX	UNITS
I <sub>D</sub>	Dark Current			280	600	nA
C <sub>J</sub>	Junction Capacitance	f = 1 MHz		130		pF
I <sub>N</sub>	Noise Current Spectral Density	f = 100 kHz		2.5	5.5	pA/√Hz
λ <sub>range</sub>	Spectral Application Range	Spot Scan	350		1050	nm
R	Responsivity	λ = 160 nm, V <sub>R</sub> = 0 V		30		A/W
V <sub>op</sub>	Operating voltage		1700		2000	V
T <sub>VBR</sub>	Temp. Coeff. Breakdown voltage	Constant Gain = 200		2		V
t <sub>r</sub>	Response Time*	RL = 50 Ω, λ = 675nm		15	22	nS

\*Response time of 10% to 90% is specified at 675nm wavelength light. Each part is supplied with gain bias voltages and dark current data.

Information in this technical datasheet is believed to be correct and reliable. However, no responsibility is assumed for possible inaccuracies or omission. Specifications are subject to change without notice.