

Datasheet

DLPCA-200

Variable Gain
Low Noise Current Amplifier



Features

- Transimpedance (gain) switchable from 1×10^3 to 1×10^{11} V/A
- Bandwidth DC/1 Hz ... 500 kHz
- Bandwidth switchable to DC ... 10 Hz for low noise DC measurements
- Bandwidth independent of detector capacitance (up to 1 nF)
- Adjustable bias voltage
- Protection against ± 3 kV transients
- Local and remote control

Applications

- Photodiode and photomultiplier amplifier
- Scanning tunneling microscopy (STM)
- Spectroscopy
- Beam monitoring for particle accelerators/synchrotrons
- Ionisation detectors
- Preamplifier for lock-ins, A/D converters, etc.

Block Diagram

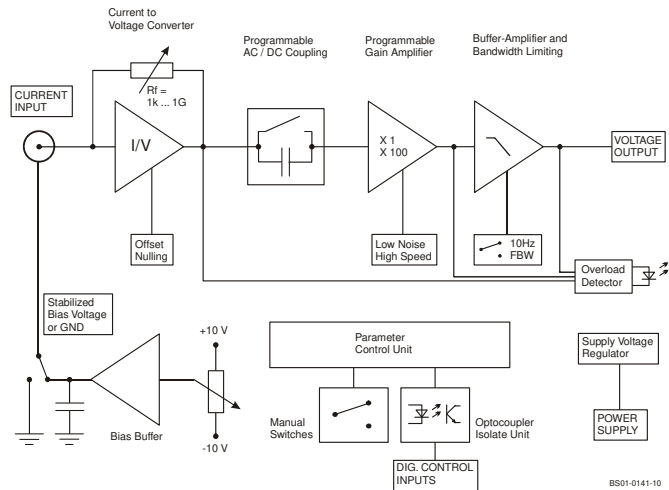

SOPHISTICATED TOOLS FOR SIGNAL RECOVERY



DE-DLPCA-200_R19/JM/02JAN2019

Datasheet

DLPCA-200

**Variable Gain
Low Noise Current Amplifier**

Specifications	Test conditions	$V_s = \pm 15\text{ V}$, $T_A = 25\text{ }^\circ\text{C}$, load impedance = $1\text{ M}\Omega$							
Gain	Transimpedance	$1 \times 10^3 \dots 1 \times 10^{11}\text{ V/A}$							
	Gain accuracy	$\pm 1\%$							
	Gain drift	see table below							
Frequency Response	Lower cut-off frequency	DC / 1 Hz							
	Upper cut-off frequency (-3 dB)	up to 500 kHz (see table below), switchable to 10 Hz							
	Gain flatness	$\pm 0.1\text{ dB}$							
Input	Equ. input noise current	see table below							
	Equ. input noise voltage	4 nV/ $\sqrt{\text{Hz}}$ (@ 1 kHz)							
	Input offset current drift	see table below							
	Input bias current	1 pA typ. (max. 3 pA)							
	Max. input current	see table below (value for linear amplification)							
	Input offset compensation	adjustable by offset potentiometer and external control voltage; max. range see table below							
Performance depending on Gain Setting	Gain setting (low noise) (V/A)	10^3	10^4	10^5	10^6	10^7	10^8	10^9	
	Upper cut-off frequency (-3 dB)	500 kHz	500 kHz	400 kHz	200 kHz	50 kHz	7 kHz	1.1 kHz	
	Rise/fall time (10% - 90%)	700 ns	700 ns	900 ns	1.8 μs	7 μs	50 μs	300 μs	
	Input noise current density ($\sqrt{\text{Hz}}$)	20 pA	2.3 pA	450 fA	130 fA	43 fA	13 fA	4.3 fA	
	measured at	10 kHz	10 kHz	10 kHz	1 kHz	1 kHz	100 Hz	100 Hz	
	Integr. input noise current (rms)*	21 nA	2.4 nA	500 pA	130 pA	41 pA	5.8 pA	0.8 pA	
	Offset current drift ($^\circ\text{C}$)	30 nA	3 nA	0.3 nA	30 pA	3 pA	0.3 pA	0.1 pA	
	Gain drift ($^\circ\text{C}$)	0.008%	0.008%	0.008%	0.01%	0.01%	0.01%	0.02%	
	Max. input current (\pm)	10 mA	1 mA	0.1 mA	10 μA	1 μA	0.1 μA	10 nA	
	Input offset compensation (\pm)	100 μA	10 μA	1 μA	0.1 μA	10 nA	1 nA	0.1 nA	
	DC input impedance (\parallel 5 pF)	50 Ω	50 Ω	50 Ω	60 Ω	150 Ω	1 k Ω	10 k Ω	
	Gain setting (high speed) (V/A)	10^5	10^6	10^7	10^8	10^9	10^{10}	10^{11}	
	Upper cut-off frequency (-3 dB)	500 kHz	500 kHz	400 kHz	200 kHz	50 kHz	7 kHz	1.1 kHz	
	Rise/fall time (10% - 90%)	700 ns	700 ns	900 ns	1.8 μs	7 μs	50 μs	300 μs	
	Input noise current density ($\sqrt{\text{Hz}}$)	13 pA	1.8 pA	440 fA	130 fA	43 fA	13 fA	4.3 fA	
	measured at	10 kHz	10 kHz	10 kHz	1 kHz	1 kHz	100 Hz	100 Hz	
	Integr. input noise current (rms)*	12 nA	1.8 nA	450 pA	120 pA	37 pA	5.3 pA	0.8 pA	
	Offset current drift ($^\circ\text{C}$)	30 nA	3 nA	0.3 nA	30 pA	3 pA	0.3 pA	0.1 pA	
	Gain drift ($^\circ\text{C}$)	0.008%	0.008%	0.008%	0.01%	0.01%	0.01%	0.02%	
	Max. input current (\pm)	100 μA	10 μA	1 μA	0.1 μA	10 nA	1 nA	0.1 nA	
	Input offset compensation (\pm)	100 μA	10 μA	1 μA	0.1 μA	10 nA	1 nA	0.1 nA	
	DC input impedance (\parallel 5 pF)	50 Ω	50 Ω	50 Ω	60 Ω	150 Ω	1 k Ω	10 k Ω	
	Output	Output voltage	$\pm 10\text{ V}$ (@ $\geq 100\text{ k}\Omega$ load)						
		Output impedance	50 Ω (terminate with $\geq 100\text{ k}\Omega$ load for best performance)						
		Max. output current	$\pm 30\text{ mA}$						
	Detector Bias	Bias voltage range	$\pm 10\text{ V}$, max. 22 mA (bias voltage connected to shield of BNC input socket, adjustable by potentiometer, switchable to GND)						

* The integrated input noise is measured with an open but shielded amplifier input in the full bandwidth ("FBW") setting. The input referred peak-peak noise can be calculated from the rms noise as follows:

$$I_{pp} = I_{RMS} \times 6$$

$$U_{pp} = I_{pp} \times \text{gain}$$

The output noise is given by:

SOPHISTICATED TOOLS FOR SIGNAL RECOVERY



Datasheet

DLPCA-200

**Variable Gain
Low Noise Current Amplifier**

Indicator LED	Function	overload
Digital Control	Control input voltage range Control input current Overload output	LOW bit: -0.8 V ... +1.2 V, HIGH bit: 2.3 V ... +12 V 0 mA @ 0 V, 1.5 mA @ +5 V, 4.5 mA @ +12 V non active: <0.4 V @ 0 ... -1 mA active: typ. 5 ... 5.1 V @ 0 ... 2 mA
Ext. Offset Control	Control voltage range Offset control input impedance	±10 V 20 kΩ
Power Supply	Supply voltage Supply current Stabilized power supply output	±15 V +120 / -80 mA typ. (depends on operating conditions, recommended power supply capability min. ±200 mA) ±12 V, max. ±50 mA, +5V, max. 30 mA
Case	Weight Material	320 g (0.74 lb.) AlMg4.5Mn, nickel-plated
Temperature Range	Storage temperature Operating temperature	-40 °C ... +100 °C 0 °C ... +60 °C
Absolute Maximum Ratings	Signal input voltage Signal input current (rms) Transient input voltage Control input voltage Power supply voltage	-16 V / +12 V 35 mA ±3 kV (out of 200 pF source) -5 V / +16 V ±20 V
Connectors	Input Output Detector bias output Power supply Control port	BNC, isolated, jack (female) BNC, jack (female) shield of input BNC Lemo® series 1S, 3-pin fixed socket (mating plug type: FFA.1S.303.CLAC52) Pin 1: +15V Pin 2: -15V Pin 3: GND Sub-D 25-pin, female, qual. class 2 Pin 1: +12 V (stabilized power supply output) Pin 2: -12 V (stabilized power supply output) Pin 3: AGND (analog ground) Pin 4: +5 V (stabilized power supply output) Pin 5: digital output: overload (referred to pin 3) Pin 6: signal output (connected to BNC) Pin 7: NC Pin 8: input offset control voltage Pin 9: DGND (ground for digital control pins 10 - 14) Pin 10: digital control input: gain, LSB Pin 11: digital control input: gain Pin 12: digital control input: gain, MSB Pin 13: digital control input: AC/DC Pin 14: digital control input: high speed / low noise Pin 15 - 25: NC

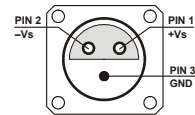

SOPHISTICATED TOOLS FOR SIGNAL RECOVERY

F E M T O

Datasheet

DLPCA-200

Variable Gain
Low Noise Current Amplifier

Remote Control Operation

General

Remote control input bits are opto-isolated and connected by logical OR function to local switch settings. For remote control set the corresponding local switches to "Remote", "AC" and "H" (High speed) and select the wanted setting via a bit code at the corresponding digital inputs. Mixed operation, e.g. local gain setting and remote controlled AC/DC setting, is also possible.

Switch settings "FBW / 10 Hz" and "Bias / GND" are not remote controllable.

Gain setting

Low noise Pin 14=HIGH Gain (V/A)	High speed Pin 14=LOW Gain (V/A)	Pin 12 MSB	Pin 11	Pin 10 LSB
10^3	10^5	LOW	LOW	LOW
10^4	10^6	LOW	LOW	HIGH
10^5	10^7	LOW	HIGH	LOW
10^6	10^8	LOW	HIGH	HIGH
10^7	10^9	HIGH	LOW	LOW
10^8	10^{10}	HIGH	LOW	HIGH
10^9	10^{11}	HIGH	HIGH	LOW

Gain settling time

<150 ms

AC/DC setting

Coupling	Pin 13
AC	LOW
DC	HIGH

Application Diagram

Photo detector biasing

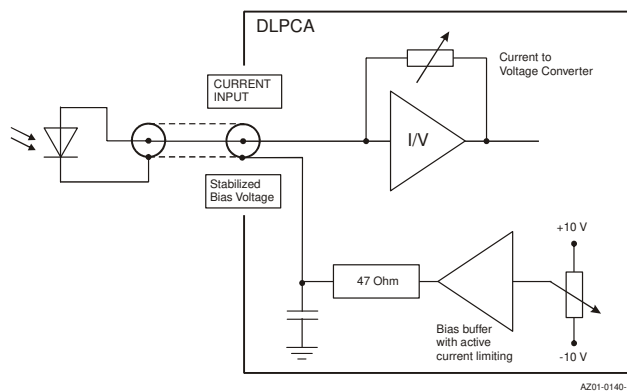

SOPHISTICATED TOOLS FOR SIGNAL RECOVERY



Datasheet

DLPCA-200

Variable Gain
Low Noise Current Amplifier

Dimensions

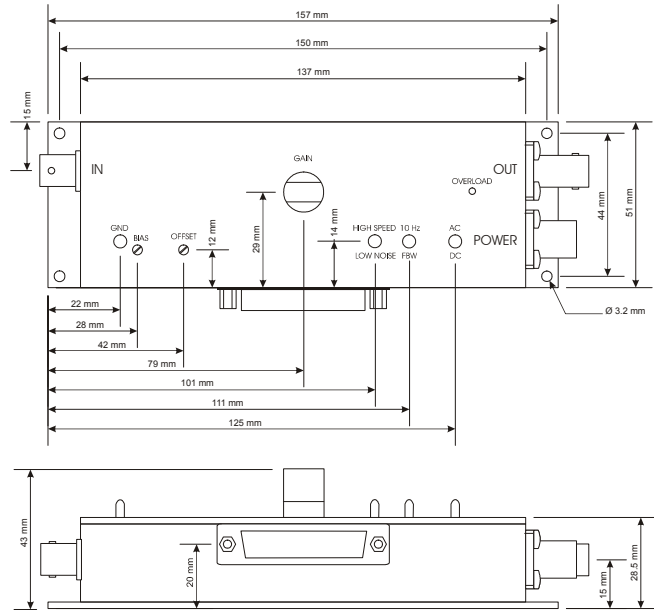

Specifications are subject to change without notice. Information provided herein is believed to be accurate and reliable. However, no responsibility is assumed by FEMTO Messtechnik GmbH for its use, nor for any infringement of patents or other rights of third parties which may result from its use. No license is granted by implication or otherwise under any patent or patent rights of FEMTO Messtechnik GmbH. Product names mentioned may also be trademarks used here for identification purposes only.

© by FEMTO Messtechnik GmbH · Printed in Germany

SOPHISTICATED TOOLS FOR SIGNAL RECOVERY

FEMTO