

DRIVER

DR-VE-10-MO

Versatile RF amplifier module

The DR-VE-10-MO is a high-grade OEM RF amplifier assembled with the latest generation of monolithic microwave integrated circuits (MMICs) chips. This confers to the device the highest performance we can expect from an RF amplifier: wide bandwidth for fast rise and fall time, high linearity, very good signal to noise ratio, and very low time jitter.

The DR-VE-10-MO is a non-inverting medium output voltage RF amplifier module. It is named VErSatile because it can be used for linear (analog, RFoF, PAM), low duty cycle pulses (square or pulse shaping, PPM) and digital modulation schemes (RZ & NRZ).

For each of these applications, the RF amplifier is factory preset with optimal setpoints for a convenient and ease of use operation. An embedded microcontroller allows the user to select the right operating mode through a Graphical User Interface. The GUI also comes with a custom tuning mode where the gain, amplitude and cross point can be optimized over a very wide tuning range.

**Features**

- Output voltage up to 8 Vpp
- Linear / pulse / digital amplifier
- Bandwidth from 16 kHz up to 11 GHz
- Preset modes

Applications

- RFoF, PAM, Analog modulation
- PPM, low duty-cycle pulse train
- Pulse carving and shaping
- Digital RZ, NRZ

Related Equipments

- Phase and intensity modulators

Performance Highlights

Parameter	Min	Typ	Max	Unit
Cut-off frequencies	16 k	-	11 G	Hz
Output voltage	-	-	8	V _{PP}
Gain	-	30	33	dB
Saturated power	-	-	23	dBm



DRIVER | **DR-VE-10-MO** | 2/10**DR-VE-10-MO**

Versatile RF amplifier module Driver

Characteristics and measurements

Parameter	Symbol	Conditions	Min	Typ	Max	Unit
Impedance	Z	-	-	50	-	Ω
Low frequency 3dB point	f_{lower}	-	-	16	25	kHz
High frequency 3dB point	f_{higher}	-	10	11	-	GHz
Small signal Gain	S_{21}	-	30	33	-	dB
Gain ripple	-	$f < 11$ GHz	-	-	+/- 1.5	dB
Input return loss	S_{11}	$f < 16$ GHz	-	-	-10	dB
Output return loss	S_{22}	$f < 12$ GHz	-	-	-10	dB
Isolation	S_{12}	$f < 20$ GHz	-	-	-60	dB

Analog Mode

Parameter	Symbol	Conditions	Min	Typ	Max	Unit
Output power 1 dB compression	$P_{1\text{dB}}$	0 - 10 GHz 10 - 16 GHz	-	21 19	-	dBm
Saturated Output power	P_{sat}	$F < 10$ GHz $V_{\text{in}} \sim 0.6 V_{\text{PP}}$	-	-	23	dBm
Input power	P_{in}	-	-	-	0	dBm
Noise figure	NF	2 - 10 GHz	2	-	4	dB
Delay time	t_d	$f < 16$ GHz	-	450	-	ps

Pulse Mode

Parameter	Symbol	Conditions	Min	Typ	Max	Unit
Pulse width	PW	-	70 p	-	300 n	s
Pulse repetition frequency	PRF	Depending on duty cycle	10	-	1 G	Hz
Input pulse amplitude	V_{in}	Square pulse	-	0.18	0.35	V_{PP}
		Pulse shaping	-	-	0.12	
Rise / Fall time	t_r/t_f	20 % - 80 %	-	24/24	28/28	ps
Output pulse amplitude	V_{out}	$V_{\text{in}} \sim 0.2 V_{\text{PP}}$	-	-	8	V_{PP}



DRIVER | **DR-VE-10-MO** | 3/10**DR-VE-10-MO**

Versatile RF amplifier module Driver

Digital Mode

Parameter	Symbol	Conditions	Min	Typ	Max	Unit
Data rate	-	-	0.1	-	10	Gb/s
Input eye amplitude	V_{in}	-	-	0.2	1	V_{PP}
Output eye amplitude (user adjustable)	V_{out}	$V_{in} \sim 0.2 V_{PP}$	2.5	6	8	V_{PP}
Saturated output eye amplitude	$V_{out_{sat}}$	$V_{in} \sim 0.25 V_{PP}$	-	-	8.5	V_{PP}
Eye cross point (user adjustable)	Xp	-	45	50	55	%
Output Jitter, RMS value	J_{RMS}	$J_{RMS} = \sqrt{J_{OUT}^2 - J_{IN}^2}$	-	120	140	ps
Rise Time / Fall Time	t_r/t_f	20 % - 80 %	-	20/20	24/24	ps
Q Factor	Q	$V_{out} \sim 6 V_{PP}$	16	18	-	-

Power supply

Parameter	Symbol	Min	Typ	Max	Unit
Supply voltage	V_{bias}	-	12	15	V
Supply current	I_{bias}	-	-	450	mA
Power dissipation	P_{diss}	-	-	6.7	W
Operating temperature	T_{op}	0	-	+40	°C



DRIVER | DR-VE-10-MO | 4/10

DR-VE-10-MO

Test conditions: Output amplitude = 70 %, Gain = 40 %, Crosspoint = 60 %, 12 V, 300 mA

S₂₁ Parameter Curve

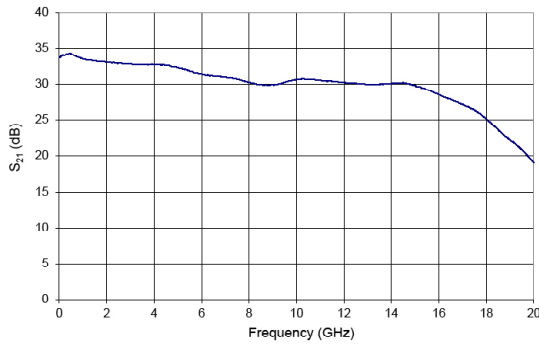

S₁₁ Parameter Curve

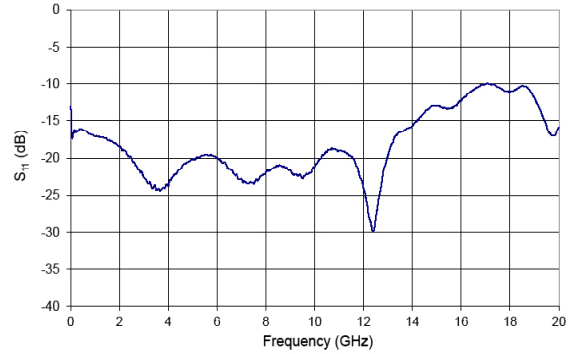

S₁₂ Parameter Curve

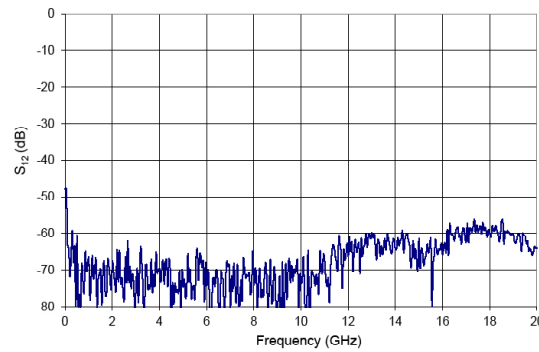

S₂₂ Parameter Curve

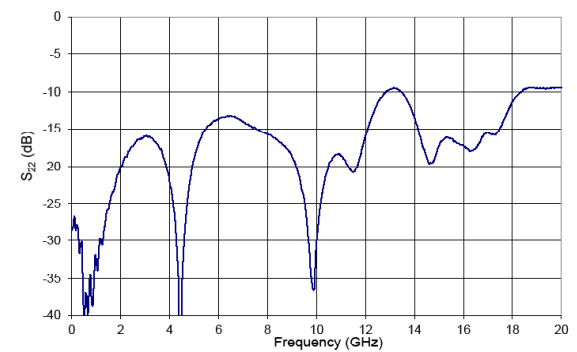

P1 dB Parameter Curve

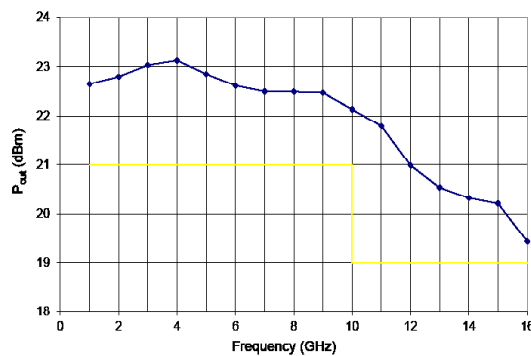

exail

DRIVER | DR-VE-10-MO | 5/10
DR-VE-10-MO

Pulse measurement (Pulse mode, square pulse, 0.18 Vpp < VIN < 0.35 Vpp)

Test conditions depends on Pulse sign ( or )



exail

DRIVER | DR-VE-10-MO | 6/10
DR-VE-10-MO

Output pulse 10 ns



Output pulse 100 ns

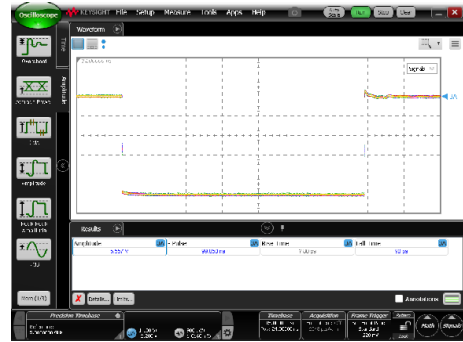

Output pulse 200 ns

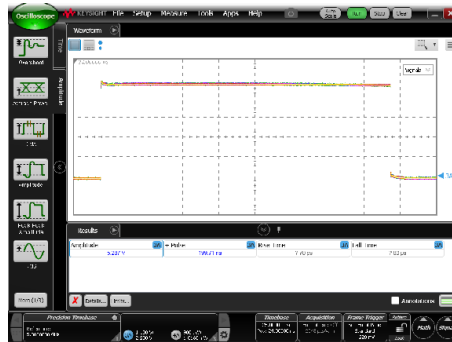

exail

DRIVER | DR-VE-10-MO | 7/10

DR-VE-10-MO

Linear Operation (Pulse mode, pulse shaping, $V_{IN} < 0.12 V_{pp}$)

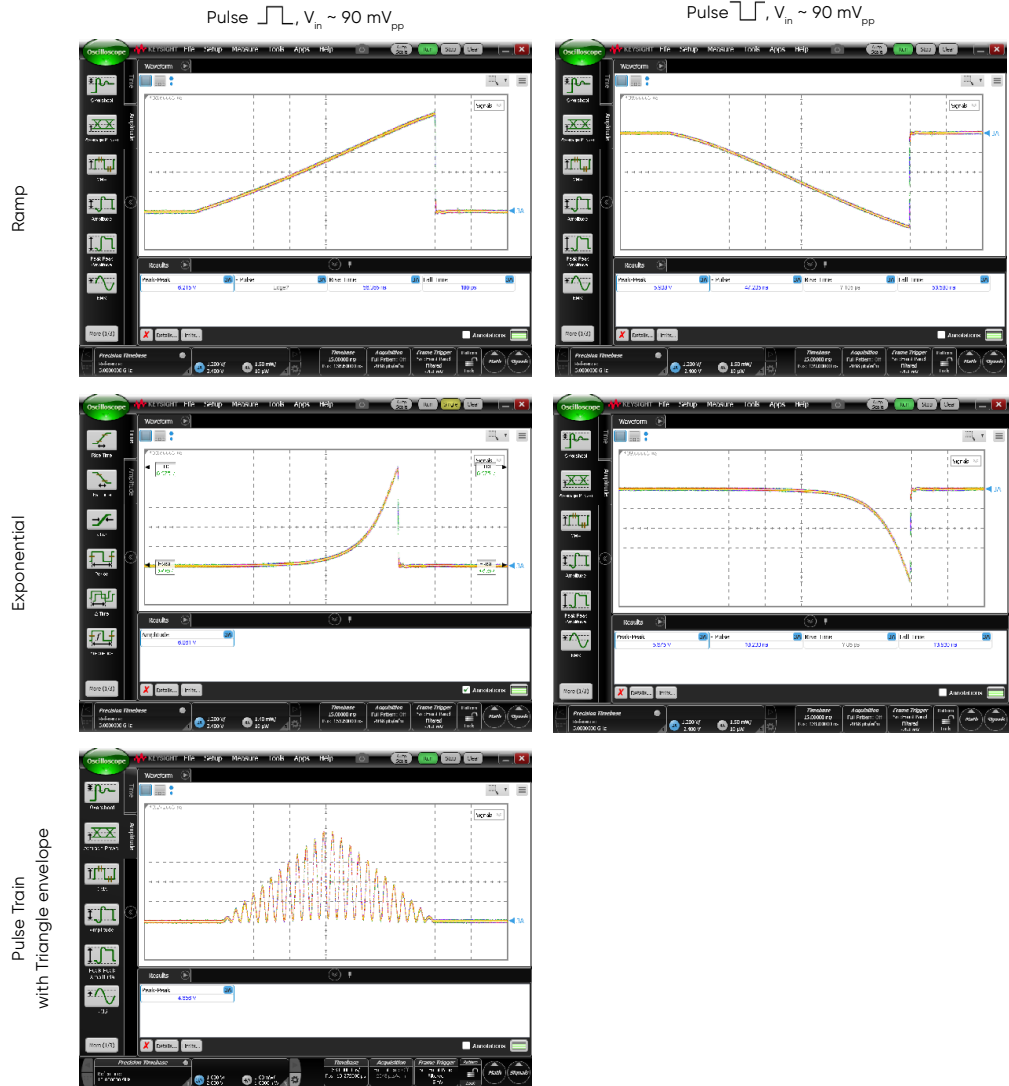

DRIVER | DR-VE-10-MO | 8/10

DR-VE-10-MO

Digital measurement:

Test conditions: Output amplitude = 45 %, Gain = 30 %, Crosspoint = 55 %, 12 V, 280 mA

Data Rate = 100 Mb/s, $V_{in} = 220 \text{ mV}_{pp}$



Data Rate = 1 Gb/s, $V_{in} = 220 \text{ mV}_{pp}$



Data Rate = 2.5 Gb/s, $V_{in} = 220 \text{ mV}_{pp}$



Data Rate = 10 Gb/s, $V_{in} = 220 \text{ mV}_{pp}$

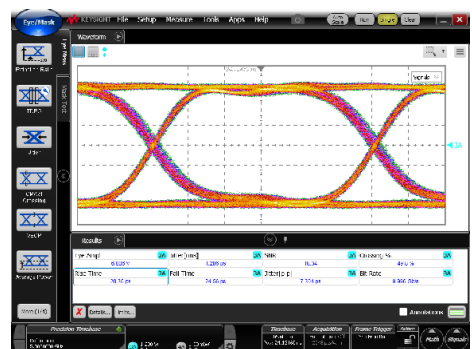

exail

DRIVER | **DR-VE-10-MO** | 9/10

Mechanical Diagram and Pinout

All measurements in mm

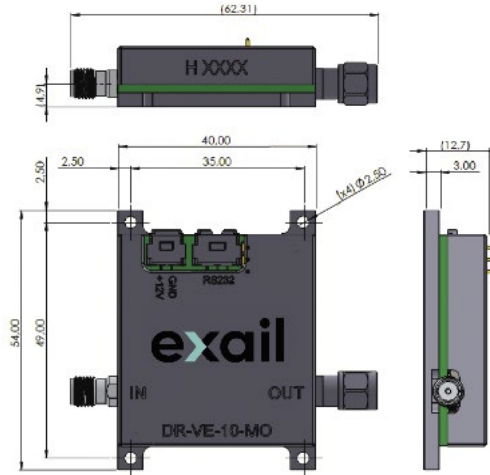

Mechanical Diagram and Pinout with HS-MO5

All measurements in mm

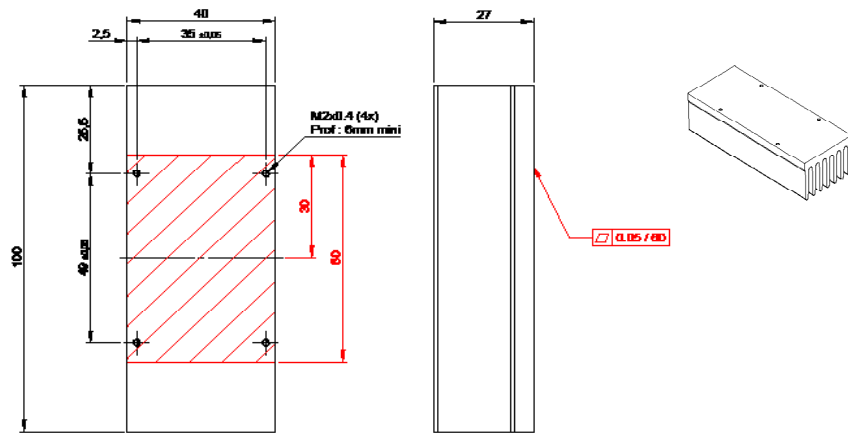

PIN	Function	Unit
Input connector	-	SMA Female
Output connector	-	SMA Male
Dimensions	Without connectors	40 mm x 54 mm x 12.7 mm

exail

DRIVER | DR-VE-10-MO | 10/10

Driver Control Application

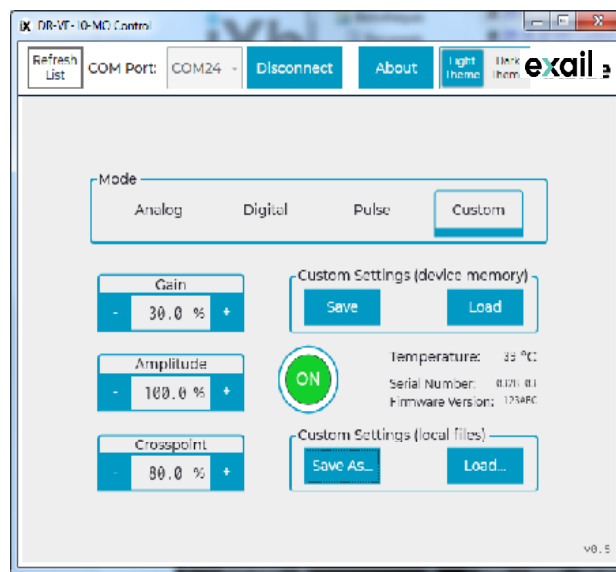

About us

Exail Photonics produces specialty optical fibers and Bragg gratings based fiber optics components and provides optical modulation solutions based on the company lithium niobate (LiNbO₃) modulators and RF electronic modules. Exail Photonics serves a wide range of industries: sensing and instruments, defense, telecommunications, space and fiber lasers as well as research laboratories all over the world.

Exail reserves the right to change, at any time and without notice, the specifications, design, function or form of its products described herein. All statements, specification, technical information related to the products herein are given in good faith and based upon information believed to be reliable and accurate at the moment of printing. **However, Exail provides no warranty (whether express or implied or statutory) as to the description, sufficiency, accuracy or completeness, merchantability or fitness for a particular purpose of any information or specification detailed herein.** No liability is assumed for any inaccuracies and/or as a result of use of the products. The user must validate all parameters for each application before any use and he shall assume all risks and responsibilities in connection with the use of the products.



07_2023_ED04 / 00026999