

➤ PRODUCT DATA SHEET

MTS2 SENS single gas

Thermal IR detectors for gas analysis



The thermo-electric IR detectors of the MTS series (Micro-Hybrid thermopile sensors) are characterized by a particularly high detectivity and longevity.

The base of each thermopile detector is formed by the so-called thermocouple. Due to thermal diffusion currents of two different metals (Seebeck effect), it generates an electrical voltage – the measurement signal. These serially connected thermocouples, called thermopiles, achieve a higher output voltage.

The sensitive component of Micro-Hybrid thermopile detectors is a MEMS-based thin-layer system on a silicon substrate. We offer sensor chips with either 80 (TS 80) thermocouples for non contact temperature measurement or 200 (TS 200) thermocouples for NDIR gas analysis. Depending on the application, both basic types are provided with different spectral absorber layers.

FEATURES

- Specialized to measure determined gases
- Different backfillings to adapt performance for chosen target gas
- Reference channel

APPLICATIONS

- **Medical technology:**
Anesthesia equipment, patient monitoring
- **Environmental engineering:**
Monitoring CH₄ in biogas plants
- **Laboratory technology / bioengineering:** Measurement of CO₂ and H₂O in cell and tissue growth, C₂H₅OH-detection
- **Industrial process control:**
Detecting SO₂, NO, CO and other process relevant gases
- **Safety technology / explosion protection:**CO₂-, CO-, CH₄-detection

BENEFITS

- **Excellent performance** due to best materials like BiSb / Sb for thermoelectrical effect
- Best detectivity
- High sensitivity

PRODUCT DATA SHEET > IR detectors > MTS2 SENS single gas | © Micro-Hybrid-Electronic GmbH | 2020-07

All rights reserved. All specifications – technical included – are subject to change without notice. No liability is accepted for any consequential losses, injury or damage resulting from the use of this document or from any omissions or errors herein.

 INFRARED COMPONENTS
AND SYSTEMS

Technical data

Technical parameter		Unit
Active area	2 x (1.2 x 1.2)	mm ²
Aperture	2 x (1.5 x 1.5)	mm ²
Number of thermocouples	200	
Time constant _(0-63%) ^{1,3}	typ. 30	ms
DC output voltage ^{1,3}	typ. 5.5	mV
DC sensitivity ^{1,3}	typ. 100	V/W
Temperature coefficient of sensitivity ²	typ. -0.4	%/K
Noise voltage ³	typ. 33	nV/Hz ^{1/2}
Noise equivalent power NEP ¹	typ. 0.33	nW/Hz ^{1/2}
Specific dectivity D* ^{1,3}	typ. 3.6*10 ⁹	cmHz ^{1/2} /W
Resistance of thermopile ³	65 ± 15	kΩ
Temperature coefficient of resistance ²	typ. -0.03	%/K
Thermistor	1 – PTC Ni1000 2 – NTC 30k 3 – NTC 100k Technical specifications see document „Thermistors“.	
Filling gas ⁴	N ₂ / Kr/ other	
Filters	see document „Infrared filters“, customized filters possible on request.	
Operation temperature	-20 ... +85	°C
Housing	T039 (modified)	

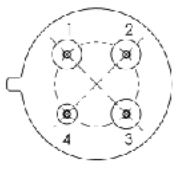
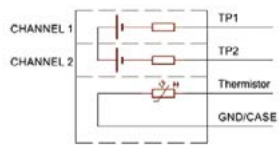
Pin out		
Bottom view		Equivalent circuit
	<ul style="list-style-type: none"> ■ Pin 1 - TP1+ ■ Pin 2 - TP2+ ■ Pin 3 - Thermistor ■ Pin 4 - GND/CASE 	

¹ T=500 K; E=38 W/m²; on air without cap

² in temperature range from +25 to +70 °C

³ at T_{amb} = 25 °C

⁴ in case of Kr-filling increase of DC output voltage, DC sensitivity, specific detectivity and time constant by the factor 1.7. Decrease of NEP by the same factor. Other gases on customer's request.

Typical operating characteristics of IR detectors > MTS2 SENS single gas

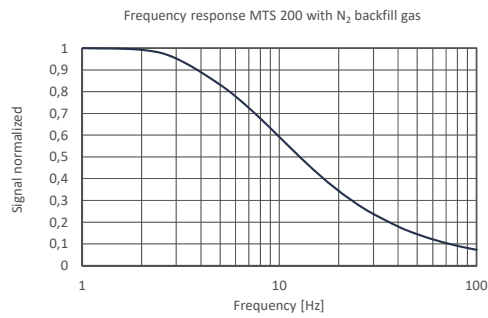

Mechanical drawings

Bottom view

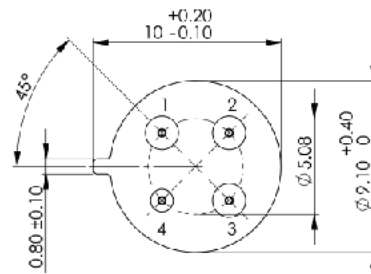

Side view

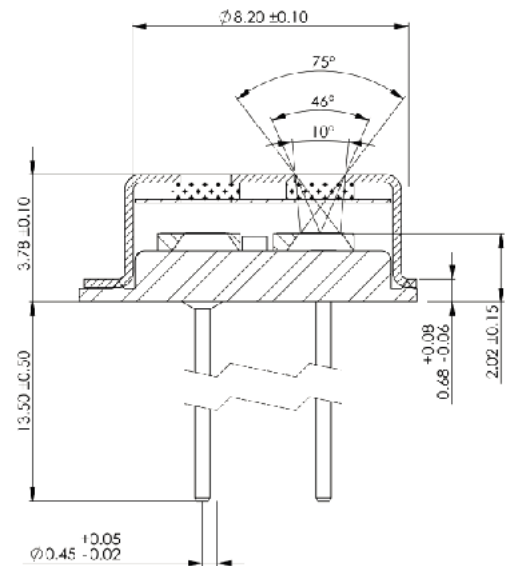

Top view

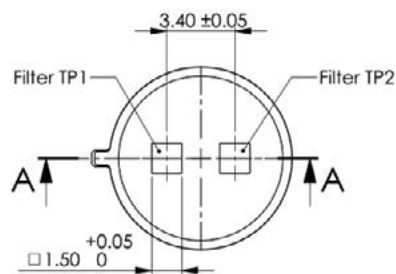

all geometrical dimensions in mm

Product overview

Article		Temp. min	Temp. max	Aperture	Channel	Application
TS2x200B-A-S1.5-1-Kr-E1/D2	s	-20 °C	85 °C	1.5 mm	2	NDIR gas analysis
TS2x200B-A-S1.5-1-Kr-G2/D2	s	-20 °C	85 °C	1.5 mm	2	NDIR gas analysis
TS2x200B-A-S1.5-1-Kr-F1/D2	s	-20 °C	85 °C	1.5 mm	2	NDIR gas analysis
TS2x200B-A-S1.5-1-Kr-H1/D2	d	-20 °C	85 °C	1.5 mm	2	NDIR gas analysis
TS2x200B-A-S1.5-1-Kr-J1/D2	d	-20 °C	85 °C	1.5 mm	2	NDIR gas analysis
TS2x200B-A-S1.5-1-N2-H1/D2	d	-20 °C	85 °C	1.5 mm	2	NDIR gas analysis
TS2x200B-A-S1.5-1-N2-J1/D2	d	-20 °C	85 °C	1.5 mm	2	NDIR gas analysis

s in stock **d** on demand

NOVA IR and **CMOS IR** are companies of Micro-Hybrid Electronic GmbH.